

UNDERHOODTM **40** AIR COMPRESSORS



Installation Manual for VMAC System

V40T033

2023+ Mercedes Sprinter
2.0 L Diesel

www.vmacair.com

Table of Contents

Safety	3
Warranty	4
General Information.....	6
Preparing for Installation	8
Installing the Dual Row Pulley	10
Installing the Main Bracket and Compressor	11
Installing the Waste Heat Air Separator Package (WHASP) Tank	17
Installing the Bulkhead Fittings.....	20
Hose Requirements	23
Connecting the Hoses	24
Adding Oil to the System	31
Installing the Control System.....	32
Air Receiver Tank.....	44
Recommended Accessories	45
Completing the Installation	46
Testing the Installation.....	48
Performance Testing	51
Digital Throttle Control Operation and Adjustments	52
Accessory Products from VMAC.....	54
Warranty Registration.....	60

Revision	Revision Details	Revised by	Checked by				Implemented
			Eng.		Tech.	Qual.	
			Mech.	Elec.			
A	Initial release	MSP	MRH	TDF	N/A	N/A	4 Oct. 2023

Additional Application Information

- Use of an air receiver tank (minimum 6 USG) is required with this application.
- 2023+ Mercedes Sprinter 2.0 L Diesel, L4 OM654.
 - Vehicle should be equipped with either prep option code N62 (preferred) or N63 (This will equip the vehicle with the Mercedes OEM dual row pulley).
 - Vehicles equipped with single row crank pulley will need to install the VMAC auxiliary pulley (supplied in kit).

Registered Trademarks

All trademarks mentioned in this manual are the property of their respective owners. VMAC's use of manufacturers' trademarks in this manual is for identification of the products only and does not imply any affiliation to, or endorsement of said companies.

Loctite®, **Loctite® 242** and **Loctite® 567** are registered trademarks of Henkel AG & Company KGaA.

Eaton Aeroquip® is a registered trademark of EATON AEROQUIP INC.

Torx® is a registered trademark of Acument Intellectual Properties, LLC

Mercedes® and **Sprinter®** are registered trademark of DAIMLER AG.

Important Information

The information in this manual is intended for certified VMAC installers who have been trained in installation and service procedures and/or for anyone with mechanical trade certification who has the tools and equipment to properly and safely perform the installation or service. Do not attempt installation or service without the appropriate mechanical training, knowledge and experience. Follow all safety precautions. Any fabrication for correct fit in modified vehicles must follow industry standard "best practices".

Notice

Copyright © 2023 VMAC Global Technology Inc. All Rights Reserved. These materials are provided by VMAC for informational purposes only, without representation or warranty of any kind, and VMAC shall not be liable for errors or omissions with respect to the materials. The only warranties for VMAC products and services are those set forth in the express warranty statements accompanying such products and services, if any, and nothing herein shall be construed as constituting an additional warranty. Printing or copying of any page in this document in whole or in part is only permitted for personal use. All other use, copying or reproduction in both print and electronic form of any part of this document without the written consent of VMAC is prohibited. The information contained herein may be changed without prior notice.

Printed in Canada

Safety

Important Safety Notice

The information contained in this manual is based on sound engineering principles, research, extensive field experience and technical information. Information is constantly changing with the addition of new models, assemblies, service techniques and running OEM changes. If a discrepancy is found in this manual, contact VMAC Technical Support prior to initiating or proceeding with installation, service or repair. Current information may clarify the issue. Anyone with knowledge of such discrepancies, who proceeds to perform service and repair, assumes all risks.

Only proven service procedures are recommended. Anyone who departs from the specific instructions provided in this manual must first ensure that their safety and that of others is not being compromised, and that there will be no adverse effects on the operational safety or performance of the equipment.

VMAC will not be held responsible for any liability, consequential damages, injuries, loss or damage to individuals or to equipment as a result of the failure of anyone to properly adhere to the procedures set out in this manual or standard safety practices.

Safety should be the first consideration when performing any service operations. If there are any questions concerning the procedures in this manual, or more information is required, please contact VMAC Technical Support prior to beginning work.

Safety Messages

This manual contains various warnings, cautions and notices that must be observed to reduce the risk of personal injury during installation, service or repair and the possibility that improper installation, service or repair may damage the equipment or render it unsafe.



This symbol is used to call attention to instructions concerning personal safety. Watch for this symbol; it points out important safety precautions, it means, "Attention, become alert! Your personal safety is involved". Read the message that follows and be aware of the possibility of personal injury or death. As it is impossible to warn of every conceivable hazard, common sense and industry standard safety practices must be observed.



This symbol is used to call attention to instructions on a specific procedure that if not followed may damage or reduce the useful life of the compressor or other equipment.



This symbol is used to call attention to additional instructions or special emphasis on a specific procedure.

Warranty

VMAC Standard Warranty (Limited)

For complete warranty information, including both VMAC Standard Warranty (Limited) and VMAC Lifetime Warranty (Limited) requirements, please refer to our current published warranty located at: www.vmacair.com/warranty



If you do not have access to a computer, please contact us and we will be happy to send you our warranty.

VMAC's warranty is subject to change without notice.

VMAC Lifetime Warranty (Limited)

A VMAC Lifetime Limited Warranty is offered on the base air compressor only and only on UNDERHOOD, Hydraulic Driven, Transmission Mounted, Gas and Gas Engine Driven Air Compressors, Multifunction Power Systems, and other products as defined by VMAC, provided that (i) the purchaser fully completes and submits a warranty registration form within 3 months of purchase, or 200 hours of operation, whichever occurs first; (ii) services are completed in accordance with the Owner's Manual; (iii) proof of purchase of applicable service kits are made available to VMAC upon request.



The VMAC Lifetime Warranty is applicable to new products shipped on or after 1 October, 2015.

Warranty Registration

The VMAC warranty registration form is located near the back of this manual. This warranty registration form must be completed and sent to VMAC at the time of installation for any subsequent warranty claim to be considered valid.

There are 4 ways the warranty can be registered with VMAC:



www.vmacair.com/warranty



warranty@vmacair.com



(877) 740-3202



VMAC - Vehicle Mounted Air Compressors
1333 Kipp Road, Nanaimo, BC, Canada V9X 1R3

VMAC Warranty Claim Process



VMAC warranty work must be pre-authorized by VMAC. Claims are processed via our dealer network. If you are not a VMAC dealer, please select one to work with via our Dealer Locator: <https://www.vmacair.com/dealer-locator/>



- 1) Communicate with VMAC Technical Support at 1-888-241-2289 or tech@vmacair.com to help diagnose/troubleshoot the problem prior to repair. VMAC technical support will require the VMAC System ID, and hours on the compressor.
- 2) VMAC will provide direction for repair or replacement of the failed components.
- 3) If requested, failed parts must be returned to VMAC for evaluation.
- 4) Dealers may login to the VMAC website to view the "VMAC Labour Time Guide" (under "Agreements") to see the allowable warranty labour times.
- 5) Warranty invoices must include the Service Ticket number, VMAC System ID#, hours on the compressor, and a detailed description of the work performed.
- 6) VMAC Warranty does not cover consequential damages, overtime charges, mileage, travel time, towing/recovery, cleaning or shop supplies.
- 7) Dealers submit warranty claims on behalf of the Vehicle Owner/End User affected by the defective part(s). The dealer ensures that all warranty credits are refunded back to the Vehicle Owner/End User who made the initial warranty claim.



In order to qualify for Lifetime Warranty (Limited), the completed warranty registration form must be received by VMAC within 3 months of the buyer receiving the Product(s), or 200 hours of operation, whichever occurs first.

If the completed warranty registration form has not been received by VMAC within 3 months of the buyer receiving the Product(s), or 200 hours of operation, the "Standard" warranty period will be deemed to commence 30 days from the date of shipment from VMAC.

Failure to follow the warranty claim process may result in denial of the warranty claim.

VMAC Product Warranty Policies & Warranty Registration can be found on the VMAC website (see previous page for URL).

General Information

Optional Equipment Compatibility

While VMAC strives to design systems compatible with optional OEM equipment (such as running boards), it is impractical to develop systems that accommodate every OEM and aftermarket option or add-on. Whenever possible, VMAC endeavors to advise of compatibility issues in the "Additional Application Information" section of the manual. Even when specific optional equipment is determined by VMAC to be incompatible, it does not preclude the vehicle upfitter or end user from modifying the optional equipment to make it compatible with the installed VMAC system. VMAC does not warranty or accept responsibility or liability for the fitment, function or safety of any products modified in any way not expressly outlined in the installation manual.

Before Starting



Note and label all parts that are removed from the vehicle as many of the OEM parts will be reused during the installation of the VMAC system.

Read this manual prior to beginning the installation to ensure familiarity with the components and how they will fit on the vehicle. Identify any variations from the application list such as vehicle model, engines, or optional equipment (e.g., dual alternator, active steering assist, etc.).

Open the package, unpack the components and identify them using the Illustrated Parts List (IPL) included in the Fastener Pack.

Hose Information

Depending on other installed equipment, it might be necessary to move the air/oil separation tank from its intended location. The hoses used in VMAC compressor systems have a specific inner liner that is compatible with VMAC compressor oil. Use of hoses other than those supplied or recommended by VMAC may cause compressor damage and may void your warranty. Please contact VMAC for replacement hoses and further information.

Ordering Parts

To order parts, contact a VMAC dealer. The dealer will ask for the VMAC serial number, part number, description and quantity. Locate the nearest dealer online at www.vmacair.com/dealer-locator or call 1-877-912-6605.



Special Tools and Parts Required

- *Recommended: Right angle impact wrench (such as Milwaukee M12, P/N: 2565-20).*
- *May be required: Pulley Counter Rotation Tool: Mercedes P/N: 654-589-00-40-00.*
- Internal and external Torx socket sets.
- Trim Removal Tool (such as Harbor Freight Tools® 67021).

Torque Specifications

All fasteners must be torqued to specifications. Use manufacturers' torque values for OEM fasteners.

The torque values supplied in Table 1 are intended for VMAC supplied components, or for use as a guide in the absence of a torque value provided by an OEM.



Apply Loctite 242 (blue) to all fasteners (except nylon lock nuts) unless otherwise stated.

Torque values are with Loctite applied unless otherwise specified.

Standard Grade 8 National Coarse Thread								
Size (in)	1/4	5/16	3/8	7/16	1/2	9/16	5/8	3/4
Foot pounds (ft•lb)	9	18	35	55	80	110	170	280
Newton meter (N•m)	12	24	47	74	108	149	230	379

Standard Grade 8 National Fine Thread					
Size (in)	3/8	7/16	1/2	5/8	3/4
Foot pounds (ft•lb)	40	60	90	180	320
Newton meter (N•m)	54	81	122	244	434

Metric Class 10.9						
Size (mm)	M6	M8	M10	M12	M14	M16
Foot pounds (ft•lb)	4.5	19	41	69	104	174
Newton meter (N•m)	6	25	55	93	141	236

Table 1 — Torque Table

Preparing for Installation



Preparation for installation is very important. Missing a step or an item can cause problems in the installation or damage to components.

- Check off each item as it is completed so that no steps are missed.



When disassembling engine components, cover the openings to prevent debris from entering the system.

- Review the contents of the system using the illustrated parts list to ensure all components are present and in the correct quantity. If any components are missing, have the system ID ready and call VMAC Technical Support.
- Remove the driver side step cover and floor mat (Figure 1).

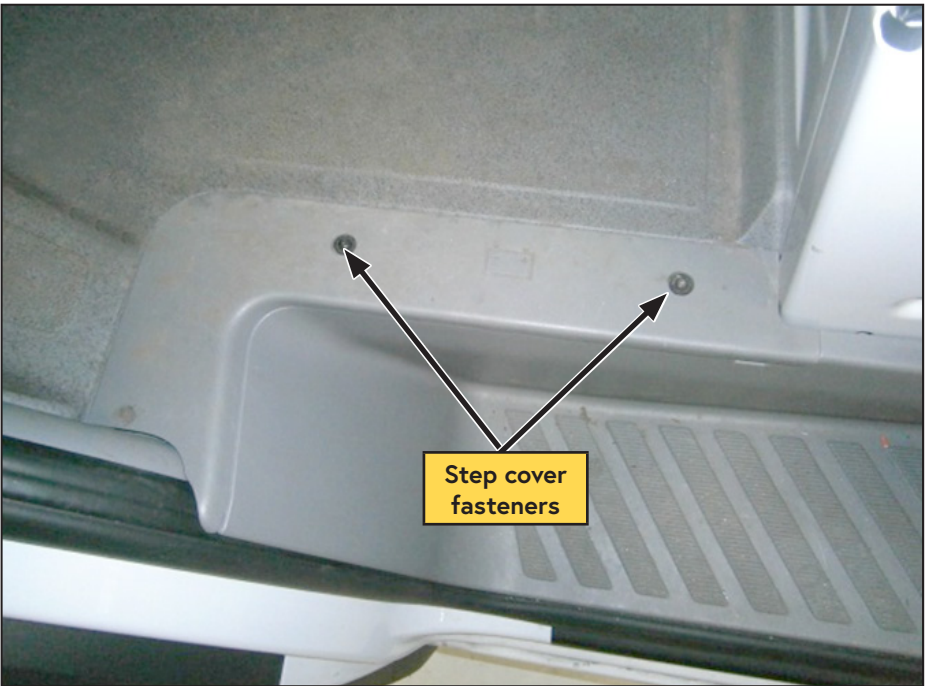

Figure 1 — Remove step cover and mat



The driver seat is heavy, use care when lifting it to prevent injury.

- Remove the driver seat.
- Remove the hatch from the driver side floorboard (Figure 2).



Figure 2 — Remove driver side hatch

- Disconnect the battery(ies).
- Determine whether the vehicle is equipped with the dual row crank pulley (Figure 3).

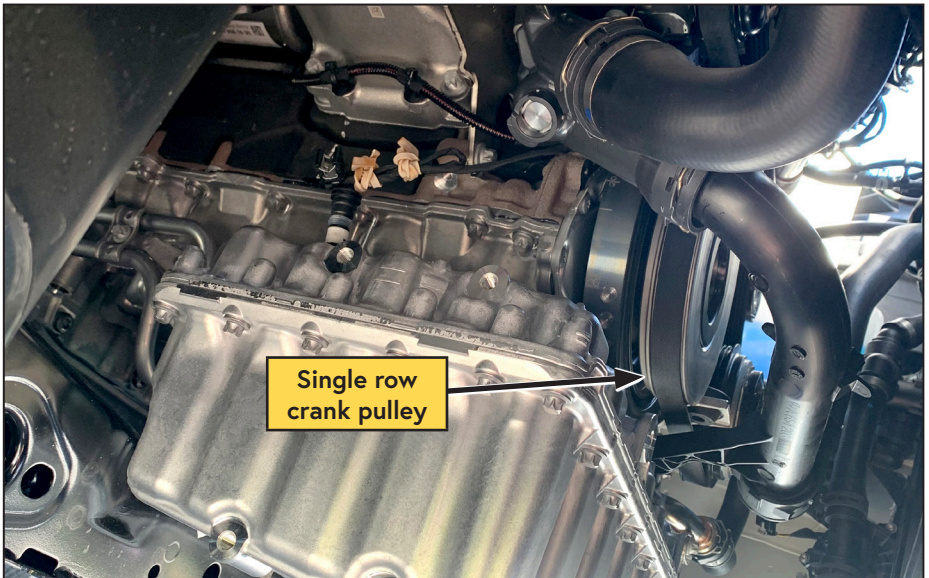

Figure 3 — Identify crank pulley

Vehicles equipped with dual row crank pulley, skip to page 11.

Installing the Dual Row Pulley



This chapter applies only to vehicles equipped with a single row crank pulley. If the vehicle is equipped with a dual row crank pulley, skip to the next chapter (page 11).

- Remove tension from OEM FEAD belt.
- Using a right angle counter rotating tool, remove the crank pulley (E12 Torx) and discard the fasteners.



Do not reuse the OEM fasteners as they are "torque to yield".

- Apply Loctite 242 (blue) to (x4) supplied crank pulley fasteners.

Using the supplied fasteners and washers, install the dual row crank pulley:*

- *Step 1: Install (x2) fasteners and washers in the counterbored holes.
- *Torque the fasteners to 43 ft•lb.
- *Step 2: Install (x2) fasteners and washers in the non-counterbored holes.
- *Torque the fasteners to 43 ft•lb.
- Re-tension the OEM FEAD belt (on the rear row of crank pulley).

Installing the Main Bracket and Compressor

- Using the supplied fasteners, install the main bracket onto the passenger side of the oil pan (Figure 4, Figure 5).

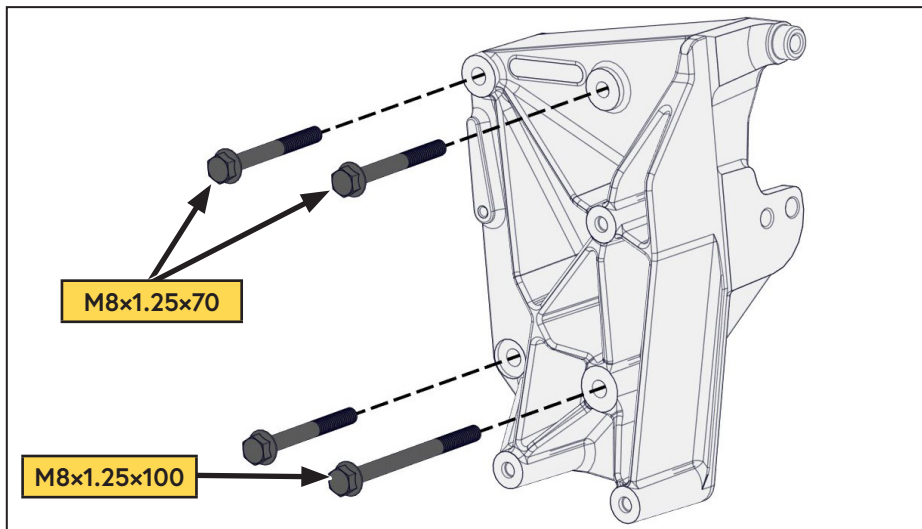

Figure 4 — VMAC Main bracket mount location



Figure 5 — VMAC main bracket installed
(idler installed in later step)

- Install the tensioner (Figure 6).

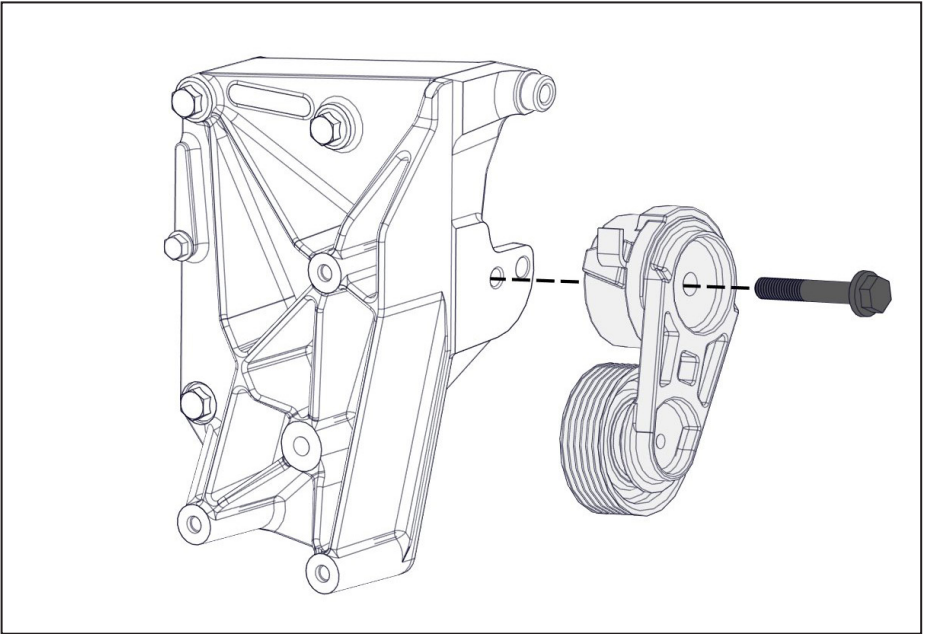

Figure 6 — Install tensioner

- Install one of the supplied idlers onto the VMAC main bracket (Figure 7).

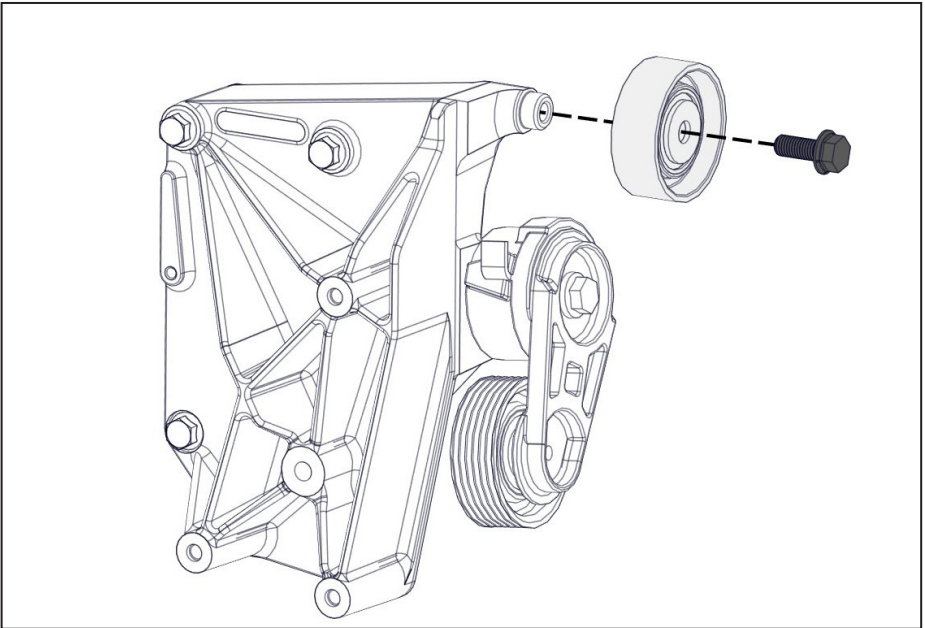

Figure 7 — Install main bracket idler

- Slide the pressure sensor assembly into the P-clip and mount it to the bracket using the supplied M6 × 1.0 × 14 mm fastener (Figure 8).

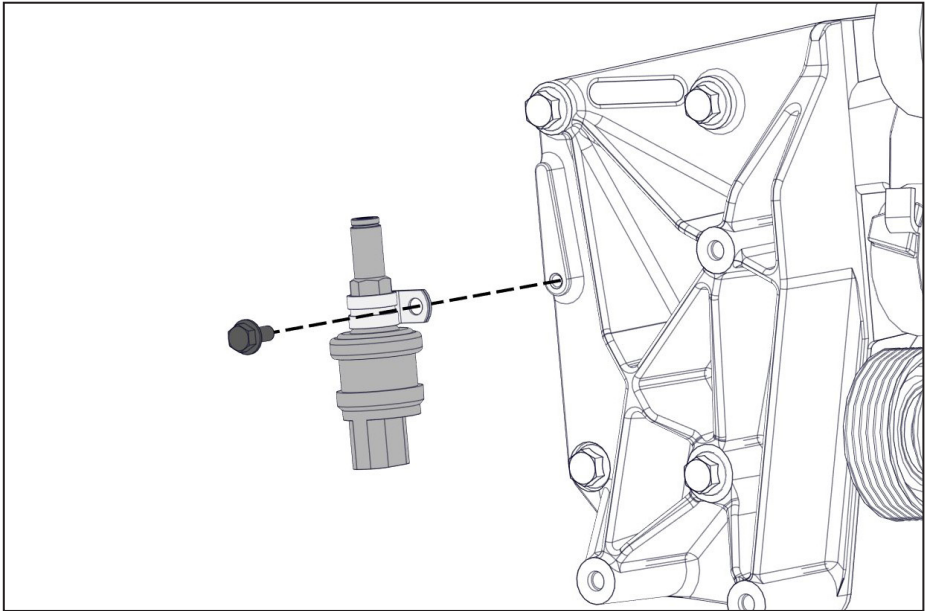

Figure 8 — Install pressure switch

- Using (×3) M8 × 1.25 × 35 mm bolts, mount the compressor assembly, and pressure switch assembly (in the orientation shown) onto the main bracket (Figure 9).

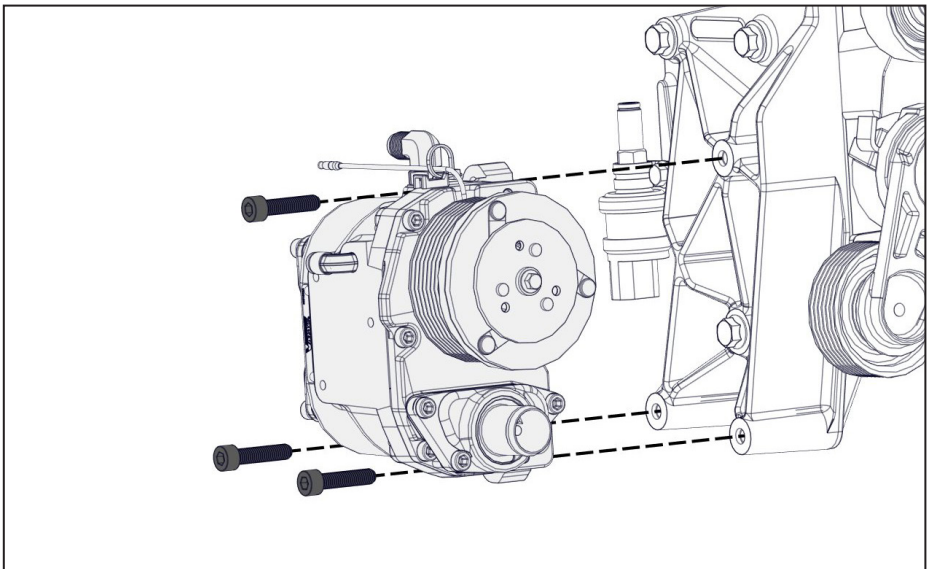

Figure 9 — Mount compressor

- Using the supplied bolt, washer, and spacer, Install the remaining idler into the tapped hole in the oil pan (Figure 10).

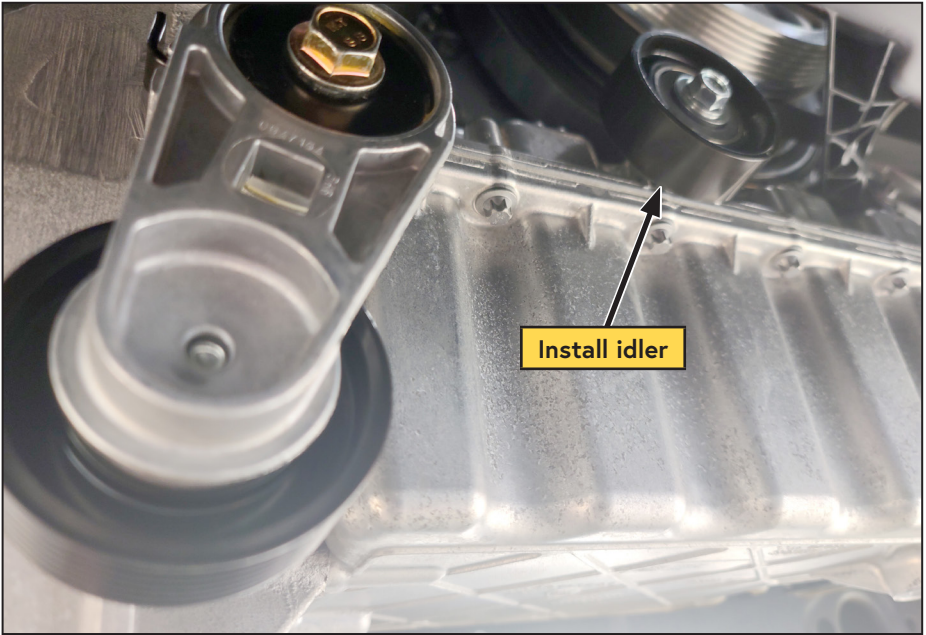

Figure 10 — Install oil pan idler

- Install and tension the VMAC belt (Figure 11).

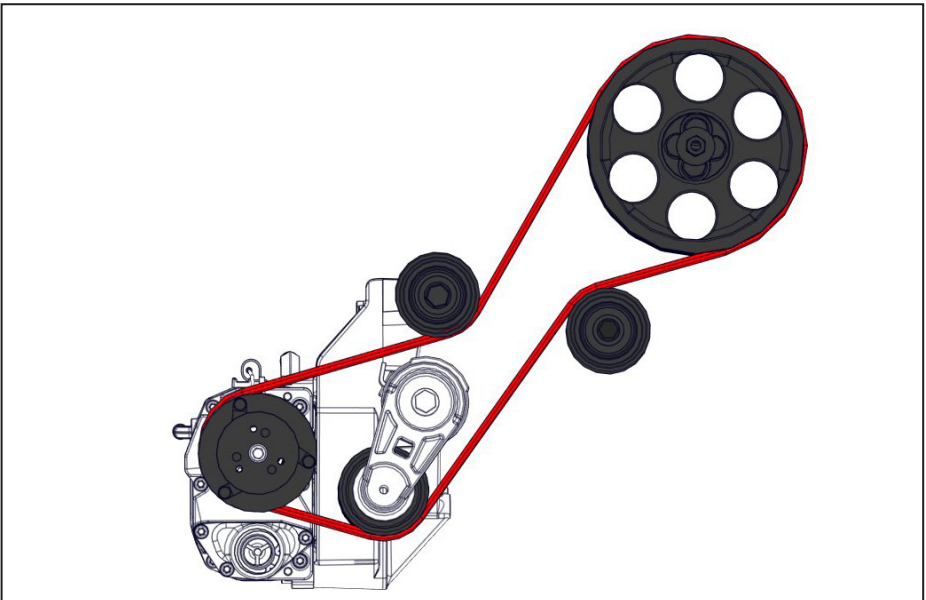

Figure 11 — VMAC belt routing

- Verify the belt is properly seated on all of the pulleys.
- Ensure the 6 rib belt is centered on the 8 rib compressor clutch. One clutch rib should be visible on each side of the belt (Figure 12).

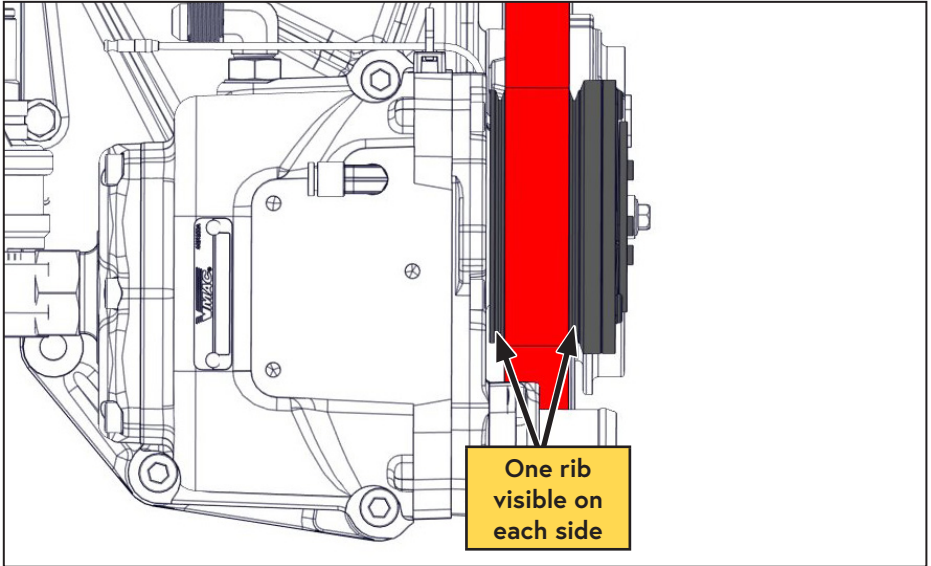

Figure 12 — Align belt on clutch

- Using the supplied M8 lock nuts, secure the air filter bracket to the driver side bumper mounting bolts (located in the void beneath the driver side headlight) (Figure 13).

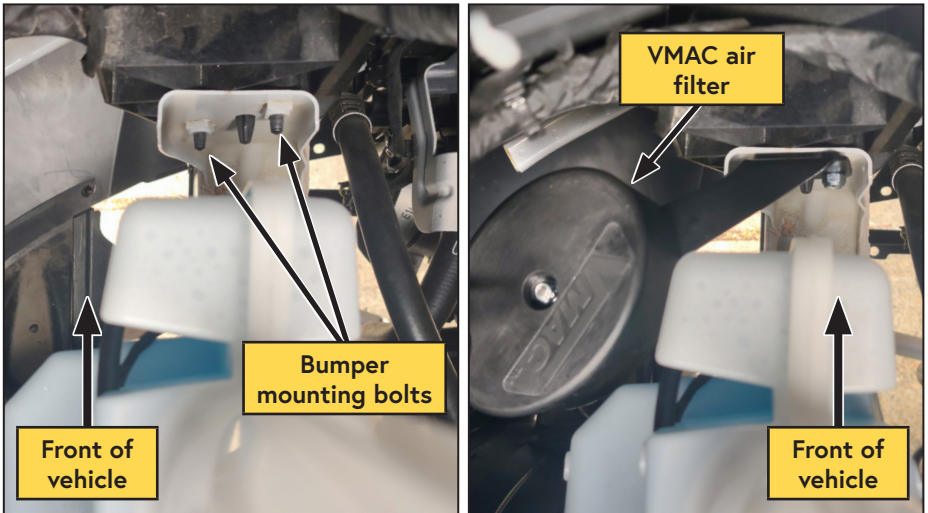

Figure 13 — Install compressor air filter bracket

- Route the compressor air intake hose from the bottom of the VMAC air filter assembly, along the cross member below the radiator, to the compressor (Figure 13).
- Secure the air intake hose to the air filter and compressor using the supplied gear clamps (Figure 14).



Figure 14 — Install remote intake hose

Installing the Waste Heat Air Separator Package (WHASP) Tank

WHASP Tank location guidelines



When determining a mounting location for the WHASP Tank, ensure the following conditions are met:

- Adequate supply of fresh air and venting for the cooling fan.
- Minimum of 12 in of clearance at the front of the cooling fan.
- Minimum of 6 in clearance at the rear of the unit.
- Hose connections and wiring are accessible.
- Mounted on a level surface.
- Impact protection.
- The oil level sight glass is easily accessible.
- The oil fill and drain ports are accessible for servicing.
- Minimize the hose lengths to maximize performance.

Mounting the WHASP Tank

Refer to (Figure 15) for mounting dimensions.

Special consideration must be made to ensure the WHASP Tank will be protected from damage and to ensure that it has adequate ventilation.

In some cases, it may be necessary to fabricate a mounting bracket to position the tank in an appropriate location.

Secure the WHASP Tank by bolting the mounting feet to the installation surface, use M8 or 5/16 in fasteners (not supplied).

Mounting in an Enclosure or Body

Mounting the WHASP Tank in an enclosure will limit access to cooling air or restrict the escape of hot air from around the unit and will have an adverse effect on cooling.

Ensure adequate ventilation is provided for the cooling system to function properly. It is not possible to make absolute recommendations regarding ventilation because of the widely differing configurations that are possible. Duty cycle, ambient temperature and enclosure shape are some of the important variables that need to be taken into account when determining the suitability of enclosure mounting.

Cool air ducted to the cooler and installing an exhaust fan to remove hot air is recommended.



Confirm the hose lengths included in this kit when determining the location of the WHASP Tank and bulkhead fittings. Hose lengths can be found in the Illustrated Parts List (IPL). If the WHASP Tank or bulkhead fitting location requires longer hoses, contact a local VMAC dealer. See page 6 for ordering information.

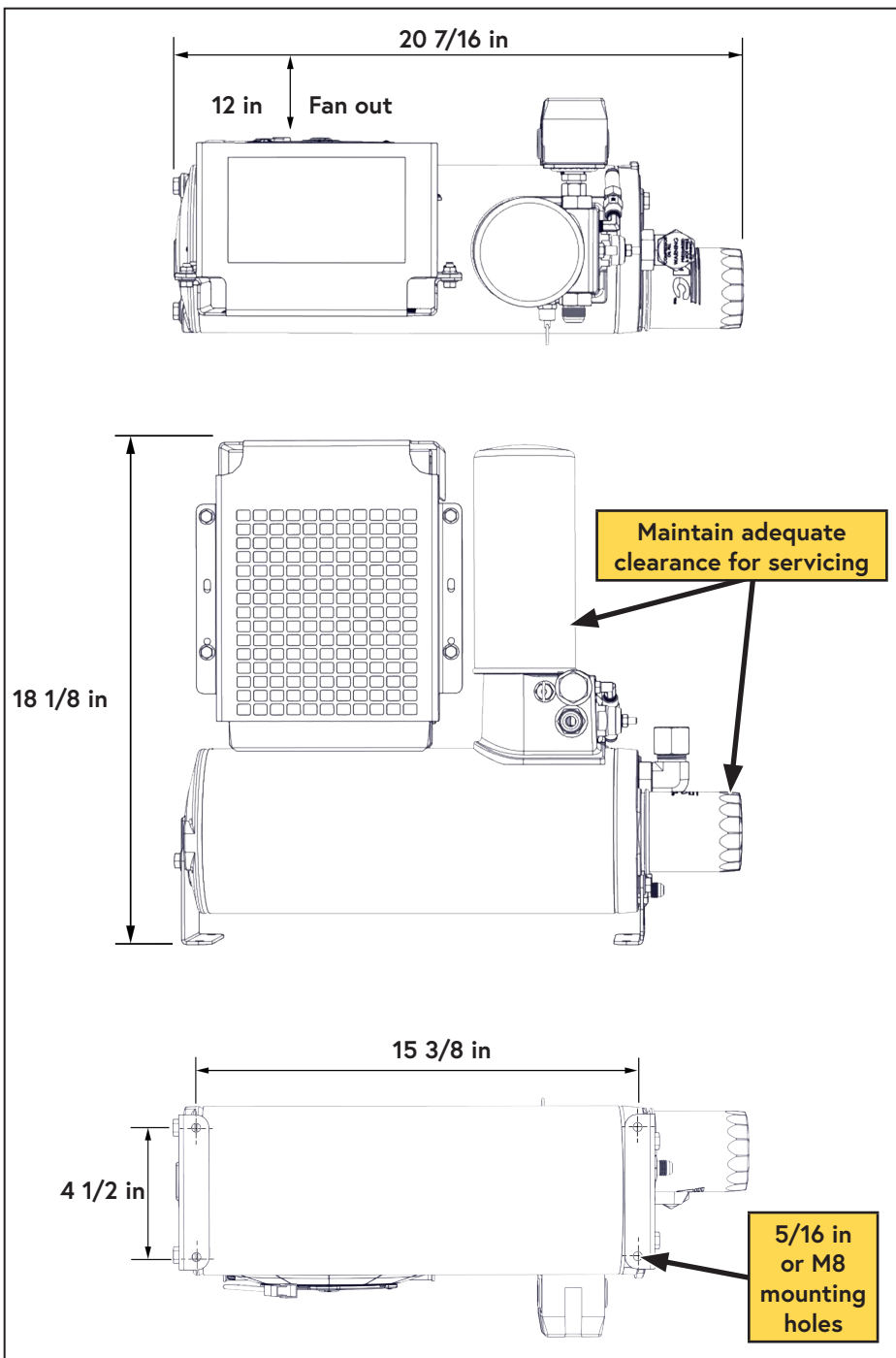

Figure 15 — Minimum WHASP Tank mounting clearances

Mounting the WHASP Tank

The WHASP Tank uses a "puller" fan to cool the air/oil mixture. Position the WHASP Tank to ensure there is adequate air flow and so that the fan is blowing out toward the cargo door. During operation, the door should be kept open to ensure there is a constant supply of cool air to prevent the system from overheating (Figure 16).

i Provide ample space to check the oil level, as well as access to the filters and compressor oil drain to facilitate servicing.

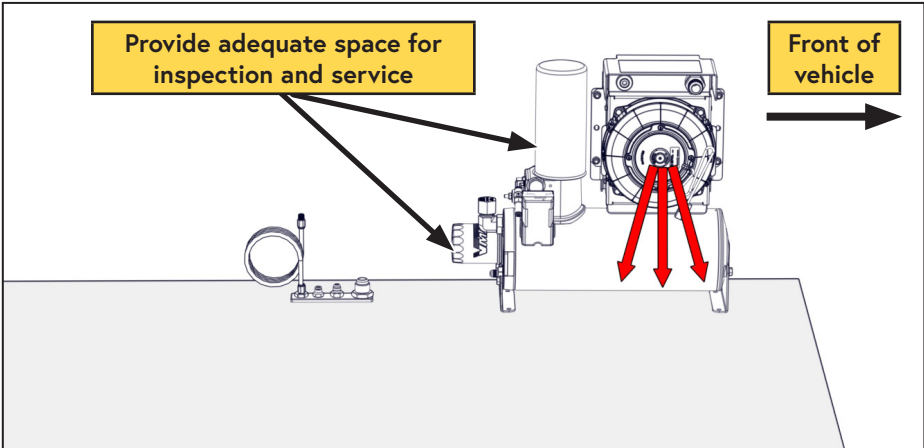

Figure 16 — WHASP ventilation

! A minimum of 6 in of clearance is recommended around the radiator (intake) side of the WHASP Tank to allow fresh, cool air to circulate into the cooler and fan (Figure 17).

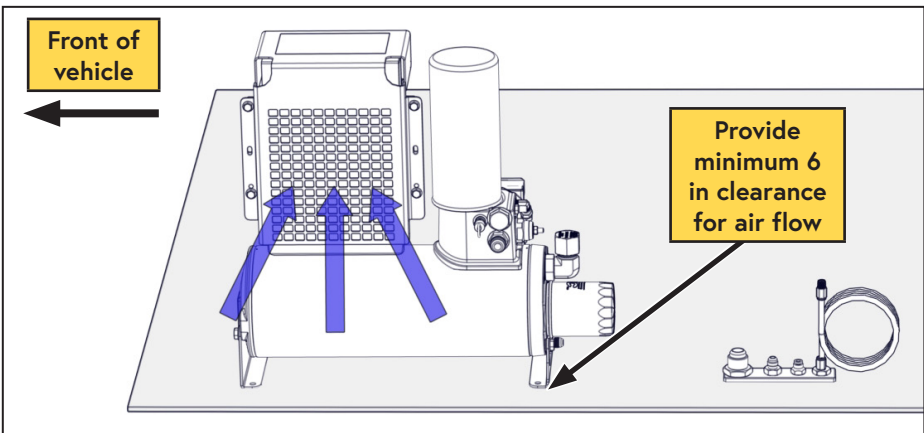

Figure 17 — WHASP ventilation

Installing the Bulkhead Fittings

(×4) bulkhead fittings, and a mounting plate are supplied with the system (Figure 18):

- 3 bulkhead fittings are used to pass the system discharge, oil, and scavenge hoses/tubes into the body of the vehicle.
- 1 bulkhead fitting is used to locate the blowdown muffler outside of the vehicle.

This kit includes hoses of a fixed length to run from the compressor to the bulkhead fittings, and from the fittings to the WHASP Tank.

To maximize compressor performance, hose lengths should be kept as short as possible; if longer hoses are required please follow the hose requirements listed on page 23 of this manual.

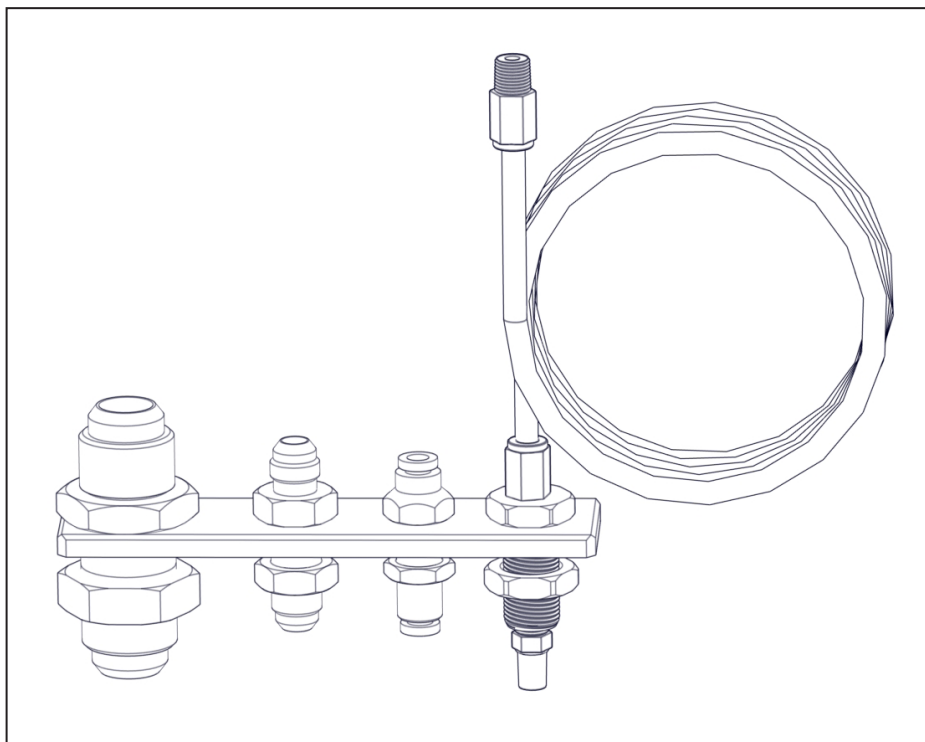

Figure 18 — Bulkhead fittings
(A700224 Remote Muffler accessory shown)



Good judgment must be used during installation. Prior to drilling any holes in the vehicle, confirm the installation location of the WHASP Tank and the bulkhead fittings. Confirm that the supplied hoses will reach from the compressor to the bulkhead fittings, and from the bulkhead fittings to the WHASP Tank. Also ensure that there are no wires, hoses, or other components on the other side of the panel that may be damaged when drilling holes.



If installing the bulkhead fittings in an alternate location, ensure the remote blowdown muffler is located where road debris (e.g. mud, ice, etc.) will not accumulate on it and prevent proper blowdown.



This kit includes hoses of an adequate length to connect to the location specified in this manual.

If installing in an alternate location:

- **Contact a VMAC dealer to order hose extensions.**

Or

- **If sourcing custom length hoses locally, refer to our knowledge base article (<https://kb.vmacair.com/help/required-vmac-hoses>) for hose requirements.**

As individual installation requirements may vary, ensure the bulkhead fittings are centered on the top of the structural ribs.

Using the bulkhead fitting mounting plate as a template, and a drill, step drill, or hole saw, drill the bulkhead fittings directly behind the passenger compartment bulkhead on the driver side. Leave enough room between the fittings to allow access for a wrench (Figure 19, Figure 20, and Figure 21).

- Discharge from the compressor: \varnothing 1 1/8 in.
- Oil return: \varnothing 9/16 in.
- Oil scavenge: \varnothing 1/2 in.
- Remote blowdown: \varnothing 5/8 in.

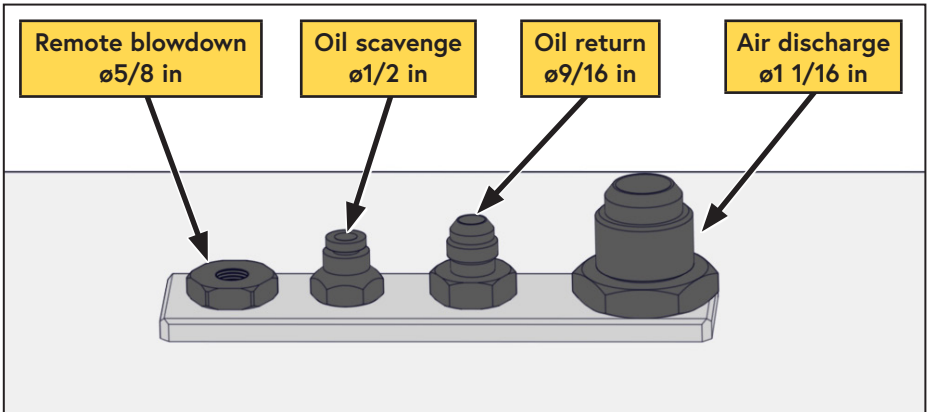

Figure 19 — Bulkhead fitting holes

- Fit the bulkhead fittings through the top of the hole and secure them from the bottom with the supplied nuts. Apply Loctite 567 (thread sealant) when installing the 1/4 in push-to-connect fittings in the bulkhead fitting (Figure 20 and Figure 21).



Figure 20 — Bulkhead fittings installed (interior view)
(some applications may not include subfloor)



Figure 21 — Bulkhead fittings installed (exterior view)

Hose Requirements



*Only attempt to shorten the supplied hose if there is access to the appropriate equipment. **Do not** attempt to cut the hose and splice it using hose clamps.*



VMAC Compressor oil will degrade rubber lined hoses, use only hoses with an AQP elastomer type liner. Contact VMAC Technical Support at 1-888-241-2289 for further information.

The 1/4 in PTFE tube, and the 3/8 in and 3/4 in hoses with AQP elastomer liner, are specifically designed to work with VMAC compressor oil and at compressor operating temperatures.

Based on the desired location of the WHASP Tank, the hose lengths provided with this system may not be ideal. They can be shortened or replaced as necessary, or hose extenders can be used.

VMAC recommends shortening these hoses as a preferred alternative to coiling up and securing the excess. **Shorter hose length will maximize system performance.**



Avoid using 90° fittings wherever possible as they cause flow restrictions and negatively impact performance.

The following hoses are included with this compressor kit:

From the compressor to the bulkhead fittings:

- 3/4 in × 122 in.
- 3/8 in × 125 in.
- 1/4 in (PTFE Tube) × 140 in.

From the WHASP Tank to the bulkhead fittings:

- 3/4 in × 96 in.
- 3/8 in × 84 in.
- 1/4 in (PTFE Tube) × 108 in.

If longer hoses are required:

To order parts, contact a VMAC dealer. The dealer will ask for the VMAC serial number, part number, description and quantity. See page 6 for ordering information.

- Eaton Aeroquip hoses with an "AQP" type inner liner are required.
- OTC fittings are required for the VMAC supplied hose.
- Push-lock fittings are suitable if FC332 hose is used.
- If Push-lock fittings are being used, do not use hose clamps as they will damage the hose and cause leaks.

Connecting the Hoses



When routing hoses, ensure cap plugs are installed so that contaminants do not get in the line. Take care when routing hoses, as a hose failure may damage the compressor and/or cause injury.



All hoses, tubes and wires that are installed, rerouted or shifted during the installation must be secured so that they do not contact any hot, sharp or moving parts. Use rubber coated P-clips wherever possible. Follow the routing suggestions in this manual and cover all hoses with plastic loom.

Push-To-Connect Fittings (Figure 22)

- Lubricate the tube and firmly push it into the fitting so that the tube fully seats in the fitting.
- Slide the collet out, away from the body of the fitting to lock the tubing in place.
- Ensure the tube does not have any 'play' to prevent the O-ring from wearing.

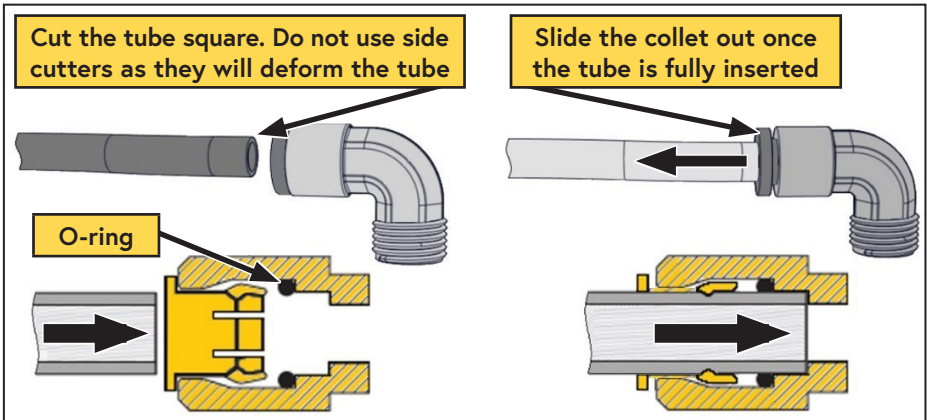

Figure 22 — Push-to-connect fittings

Connecting the Interior Hoses (Figure 23)

- Connect the straight ends of the shorter 3/4 in and 3/8 in hoses to the top side of the bulkhead fittings.
- Connect the shorter 1/4 in PTFE tube to the top side of the bulkhead fitting.
- Bundle the PTFE tube and hoses together and route them to the WHASP Tank.
- Connect the 90° fitting on the 3/4 in hose to the #12 JIC fitting (air/oil inlet) on the cooler above the fan (Figure 23).
- Connect the 90° fitting on the 3/8 hose to the #6 JIC fitting (oil return fitting) beneath the oil filter on the tank (Figure 23).
- Connect the 1/4 in PTFE tube to the 1/4 in push-to-connect (oil scavenge) fitting near the coalescing filter (Figure 23).
- Connect the discharge fitting (#8 male JIC) to the customer's air system (hose not supplied).
- Secure all hoses, tubes, and wires with P-clips and and/or cable ties.

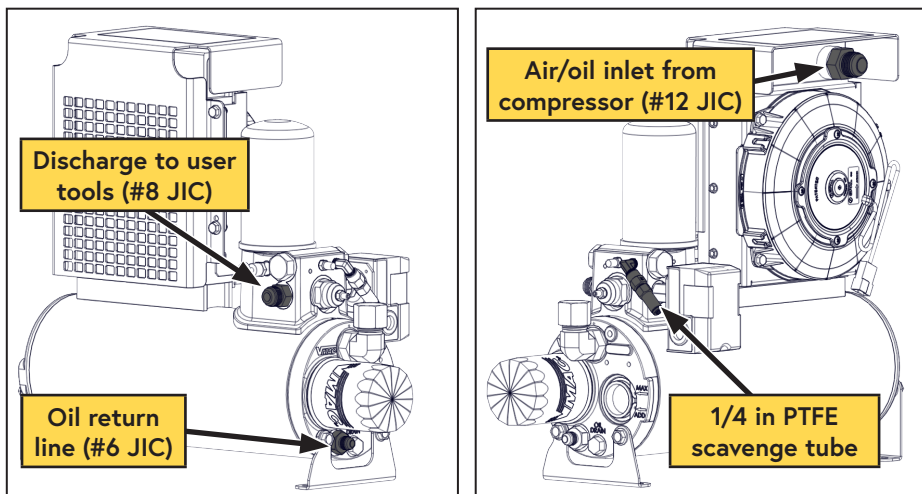

Figure 23 — WHASP Tank connections



Use of an air receiver tank (minimum 6 USG) is required with this application.

Follow the instructions on page 44 of this manual to prevent damage to the system.

Remote Muffler Installation

The WHASP Tank automatically depressurizes when the clutch disengages. This prevents damage to the compressor on the next start up.

Installing the blowdown muffler outside of the vehicle will reduce cabin noise during blowdown, and will ensure any oil vapor will be safely discharged outside of the vehicle.

- Remove the blowdown muffler from the side of the WHASP Tank (below the coalescing filter) (Figure 24).

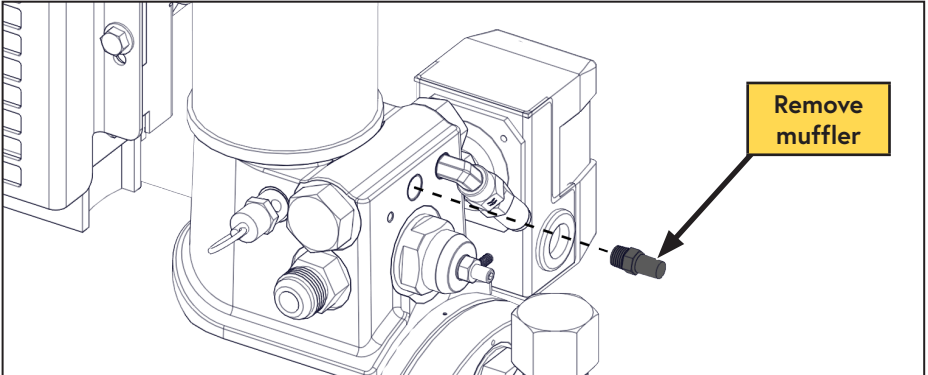

Figure 24 — Remove blowdown muffler



Ensure no debris enters the WHASP Tank manifold. Contamination of the assembly may cause erratic performance.

- Separate the PTFE tube from the fittings.
- Apply the supplied 1/4 in split loom to the 1/4 in PTFE tube.
- Apply Loctite 567 (thread sealing) compound to the 1/4 in push-to-connect fitting and install it into the threaded hole which previously held the blowdown muffler (Figure 25).

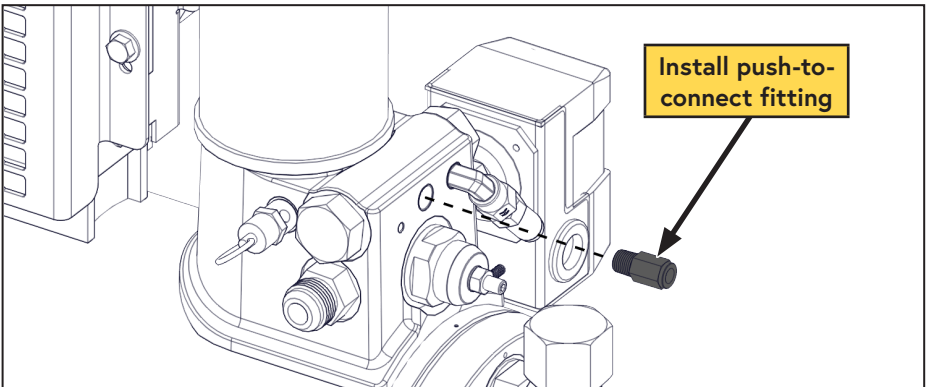

Figure 25 — Install push-to-connect fitting

- Connect the 1/4 in PTFE tube into the push-to-connect fitting installed in the WHASP Tank (Figure 26).

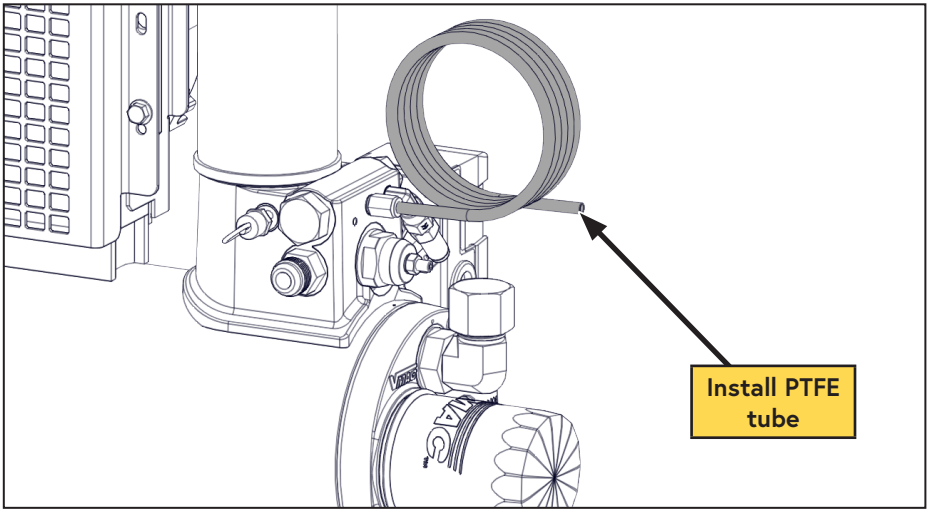

Figure 26 — Tubing Installation

- Route the 1/4 in PTFE tube to the bulkhead fitting, ensuring the tube will not kink, and cut the hose to length.



Ensure the tube is cut square and that there are no sharp edges. Do not use side cutters as this will deform the hose.

- Install the tube into the push-to-connect bulkhead fitting (Figure 27)

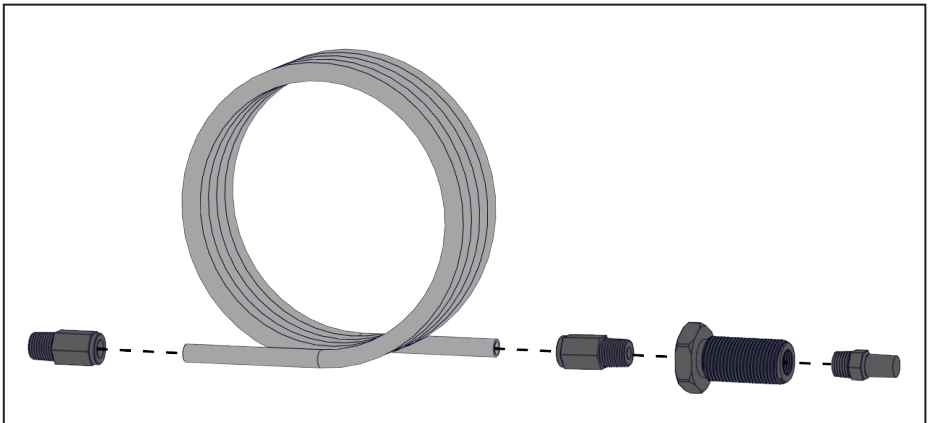

Figure 27 — Tubing Installation Remote Blowdown Muffler assembly

- Secure the tube with the supplied cable ties.

Connect the Exterior Hoses



Ensure the distance between the pressure switch and the Union Tee is no more than 24 in, and the distance between the compressor and the Union Tee is no more than 6 in

- From the 24 in spool of 1/4 in PTFE tubing, connect the scavenge tube to the compressor, pressure switch assembly, and Union Tee (Figure 28).

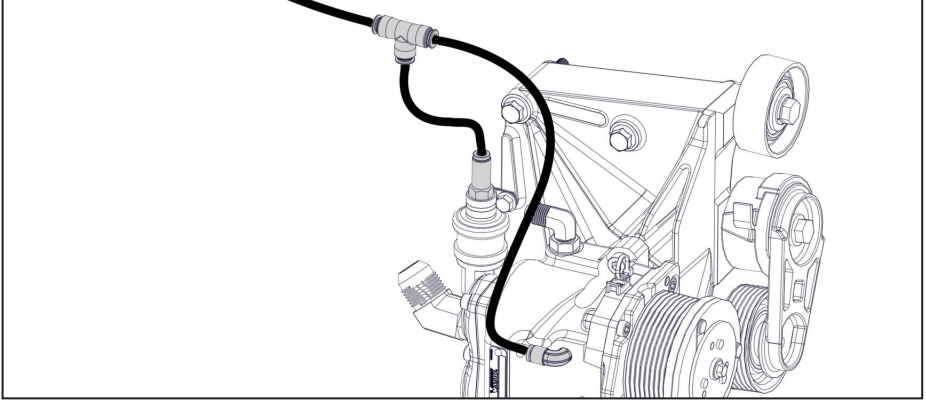

Figure 28 — Install pressure switch

- Apply loom (not supplied) to the longer 3/4 in and 3/8 in hoses, and 1/4 in PTFE tube.
- Connect the 3/4 in and 3/8 in hoses to the compressor.
- Route the 3/4 in and 3/8 in hoses, as well as the 1/4 in PTFE tube, over the frame crossmembers and steering rack (Figure 29).

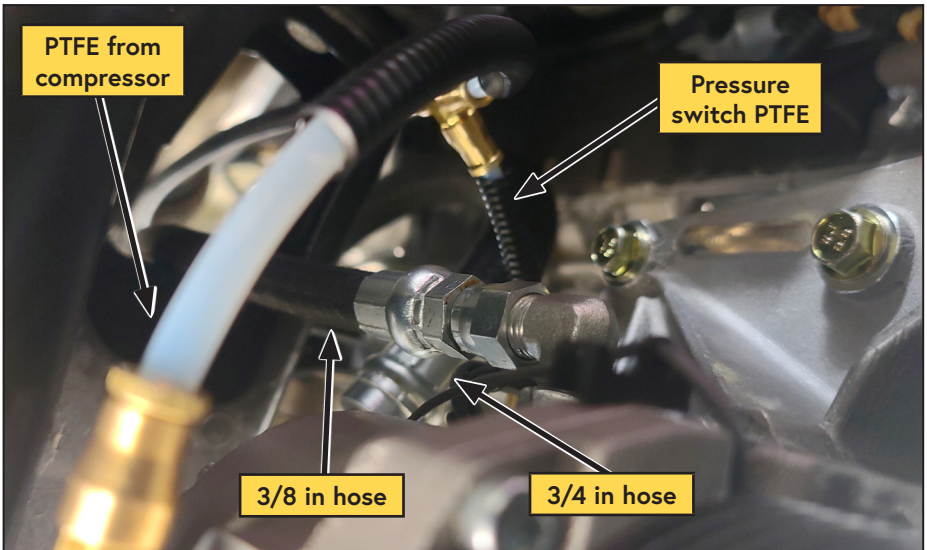

Figure 29 — Install hoses

- Route the hoses and PTFE tube along the rear edge of crossmember, behind suspension, and over to the driver side of the vehicle (Figure 30).



Figure 30 — Route hoses



Supplemental HVAC components may, or may not be present along the hose routing.

- Route the hoses along the base of the frame/body, and up to the bulkhead fittings installed earlier (Figure 31, Figure 32, and Figure 33).

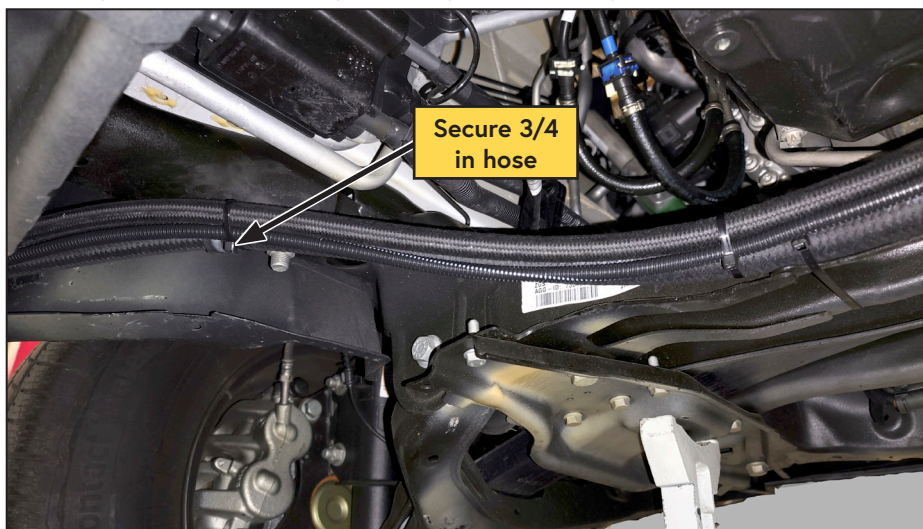

Figure 31 — Route hoses

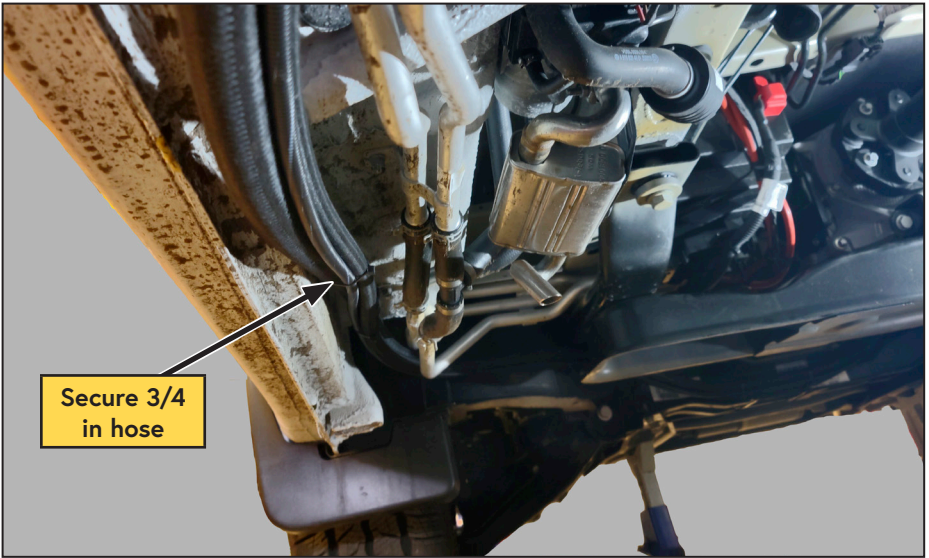

Figure 32 — Route hoses

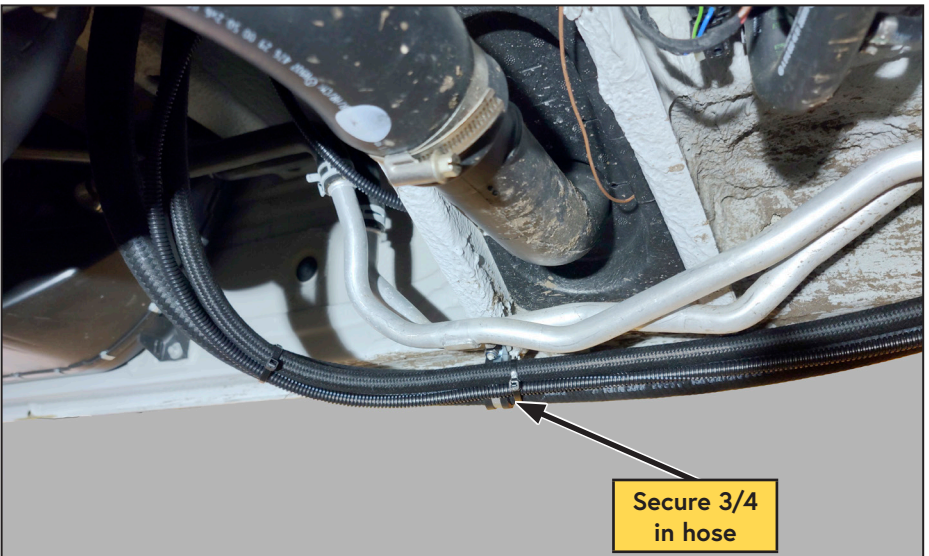

Figure 33 — Route hoses



When securing the hoses, ensure there is sufficient slack in the hose routing to allow for normal engine and body movement.

- Connect the hoses and PTFE tube to the bulkhead fittings.
- Using the supplied P-clips and fasteners, secure the 3/4 in hose to the 6 mm studs on the body (Figure 31, Figure 32, and Figure 33).
- Using cable ties, secure the 3/8 in hose and 1/4 in PTFE tube to the 3/4 in hose.

Adding Oil to the System



The VMAC supplied and approved compressor oil must be used in this system. Failure to use this special oil will result in damage to the compressor and will void warranty.

Do not overfill the system. Overfilling the system with oil can flood the sight glass window and make the system appear empty.

- Remove the fill cap on the WHASP Tank (above the sight glass) (Figure 34).
- Using a funnel, pour oil into the tank until the oil level in the sight glass reaches the "MAX" line. **The system capacity is 4 L** (Figure 34).
- Reinstall the fill cap and tighten it securely. Ensure the fill port remains accessible as it will be necessary to check and top up the oil after the first compressor start.

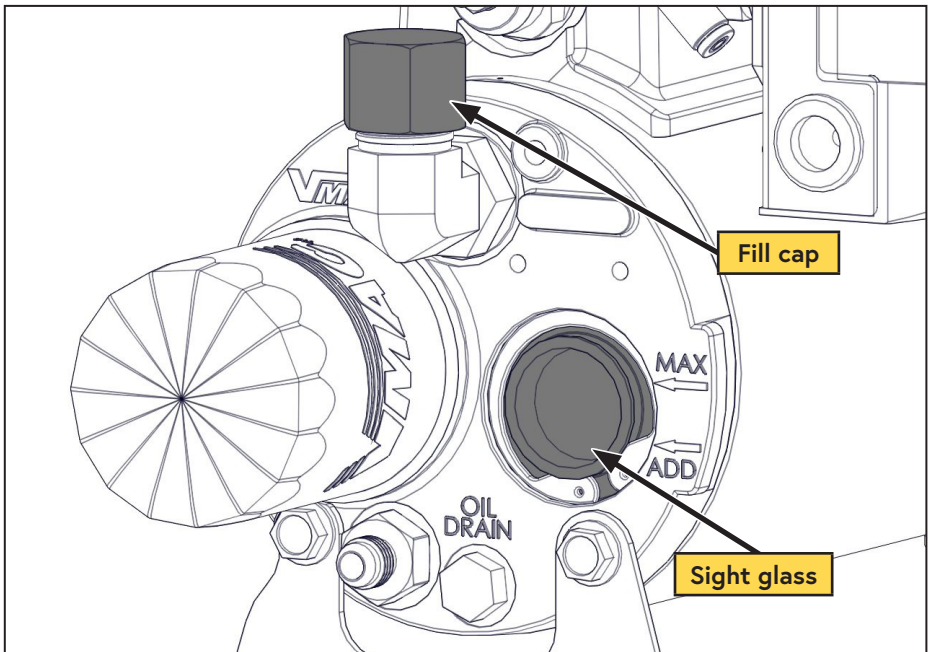

Figure 34 — Filling the WHASP Tank

Installing the Control System

Best Practices

- To confirm a good ground, use an ohm meter to measure the resistance between the ground point and the negative battery terminal. Resistance should be less than 1 Ω .
- Route all wires to ensure they will not contact hot, sharp or moving parts (including the park brake mechanism, steering column, and pedals).
- Before drilling any holes ensure there are no OEM wires, hoses, or components that may be damaged.
- Do not use a test light to probe for power on vehicle circuits, the increased current draw of the test light may damage components.
- VMAC recommends using only sealed crimp and solder butt connectors for all electrical connections.
- To ensure a durable connection, use only good quality crimping tools.
- Apply loom to all wiring:
 - Use high temperature loom in areas where high temperatures may be expected.
 - Use spiral loom in areas with high vibration.

In-line Butt Splice Connections

- Cut the wire approximately 2 in from the connector.
- Strip approximately 3/8 in from the end of both sides of the cut wire, as well as from the end of the wire being spliced in-line.
- Twist the wire to be spliced in-line, together with the "live" side of the wire (not the wire attached to the connector).
- Slide the butt connector onto the twisted wires and crimp it.
- Insert the "connector side" of the wire into butt connector and crimp it.
- Lightly tug the wires to ensure they are properly crimped.
- Using a heat gun, carefully apply heat to the butt connectors to seal the connection.

Posi-Tap Connectors

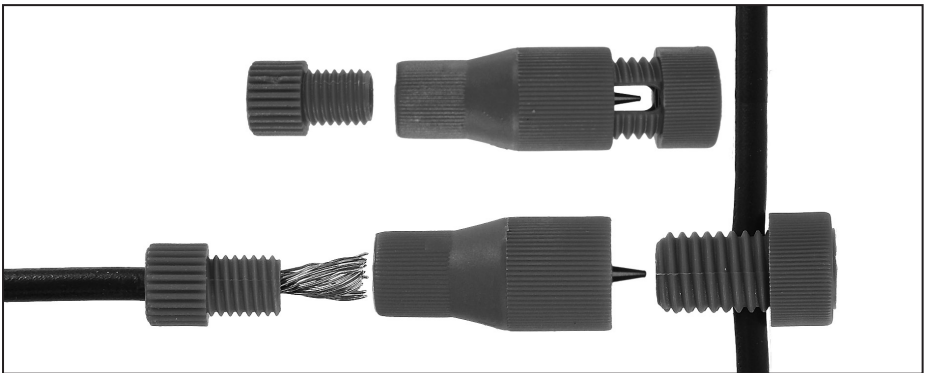

Figure 35 — Posi-Tap wire connector

- Slide the OEM (live) wire into the slot on the large cap as far as it will go.
- Thread the tap (barrel with pin) over the slotted cap, ensuring the pin is centered on the wire. Firmly tighten the tap.
- Strip approximately 3/8 in from the end of wire.
- Unscrew the small cap.
- Twist the wires together and insert the wire into the cap.
- Deflect the wires to one side.
- Insert the cap into the tap, ensuring the wires enter one side of the metal core.
- Ensuring the wire does not slip out of the cap, push and turn until the threads catch and firmly tighten the cap.
- Ensure all of the connections are firmly tightened by hand (overtightening will cause the threads to strip).

Tying into OEM connectors

Some OEM connectors may have locking tabs that must be disengaged prior to inserting a crimped connector.

Control Components Overview

Electrical Modules

- The throttle control, control module, and interface panel are not weather proof; ensure they are mounted where they will be protected from rain, snow, mud, direct sunlight, etc. (e.g. inside the cab, service body or cabinet).
- Keep the rear of the Interface Panel protected.
- Ensure the control module and throttle control are mounted away from the pedals, park brake mechanism, or where they could be inadvertently knocked by occupants.

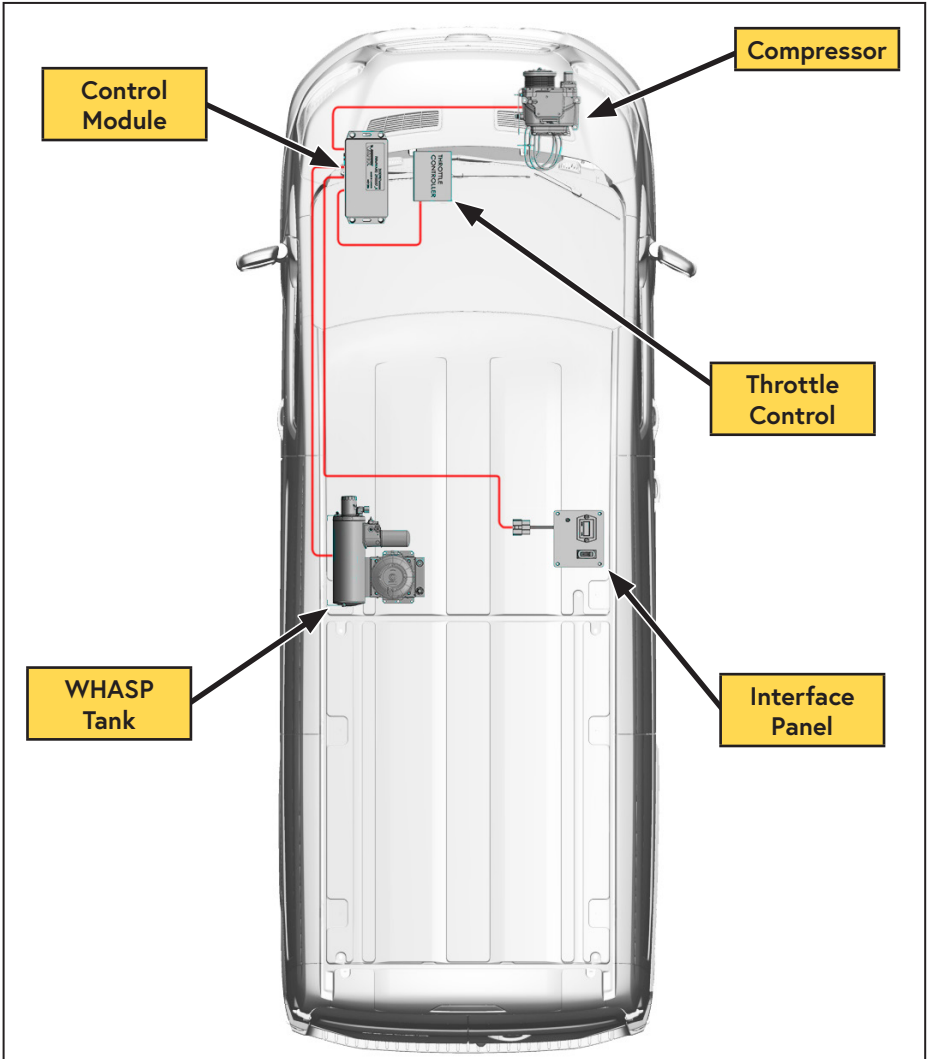

Figure 36 — General component overview
(Actual installation locations may vary)

Control Module (Figure 37)

The control module serves as the primary input/output interface between the vehicle and the various VMAC components (compressor, throttle control, WHASP Tank, interface panel, etc.).

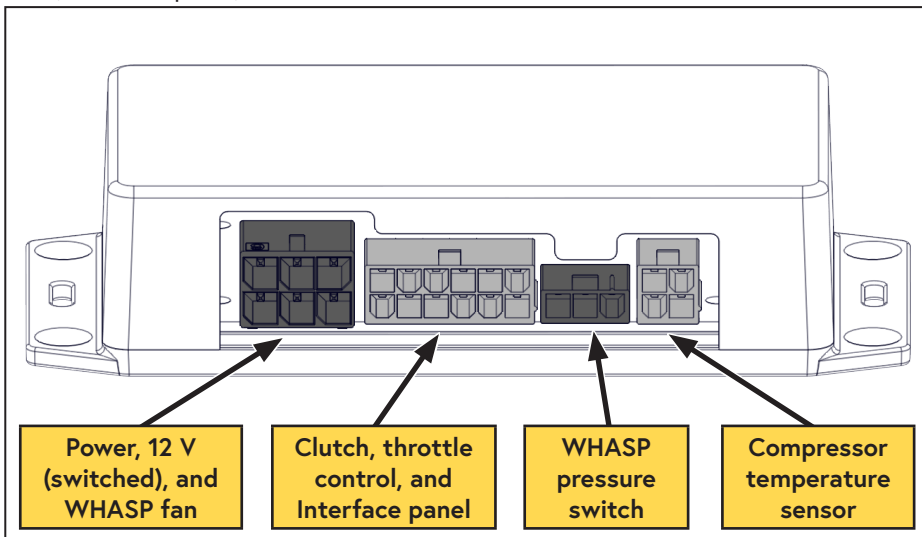

Figure 37 — Control module

Interface Panel (Figure 38)

The interface panel serves as the operator's control panel and contains the "ON/OFF" switch, compressor status light, and the compressor hour meter.

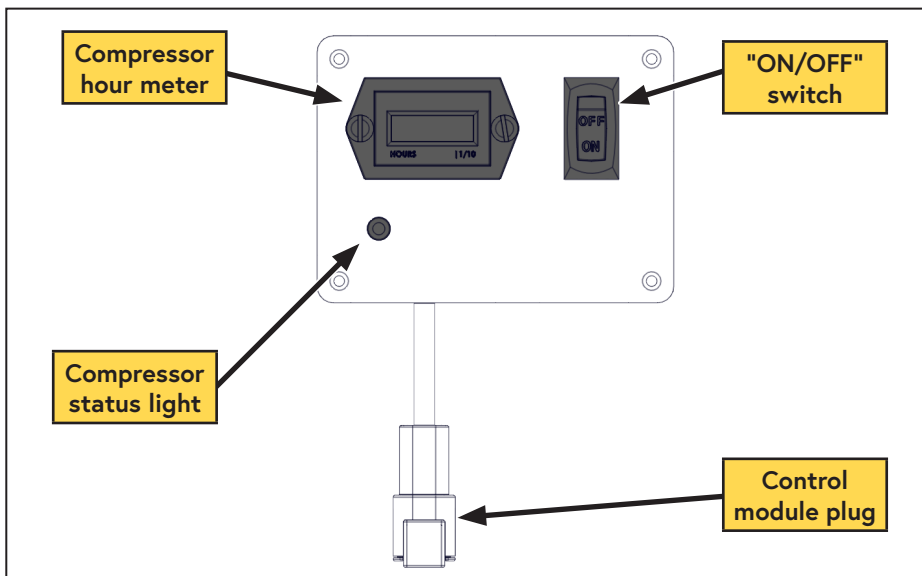

Figure 38 — Interface panel

Throttle Control (DTC) (Figure 39)

The throttle control responds to signals from the control module and commands the vehicle's throttle to increase or decrease engine speed in response to air demand.

The throttle control also allows the operator to configure the vehicle's engine speed (when air is demanded) to their needs (maximum cfm, specific tool requirements, fuel efficiency, or a combination of these factors).

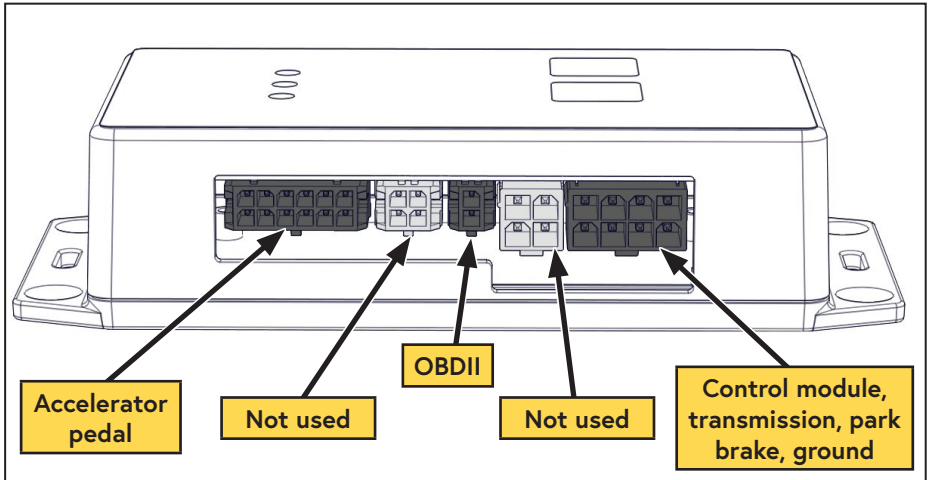

Figure 39 — VMAC digital throttle control

Mechanical Pressure Switch (Figure 40)

The mechanical pressure switch is mounted on the side of the WHASP Tank and limits the maximum pressure to a safe amount by disengaging the clutch once system pressure is achieved.

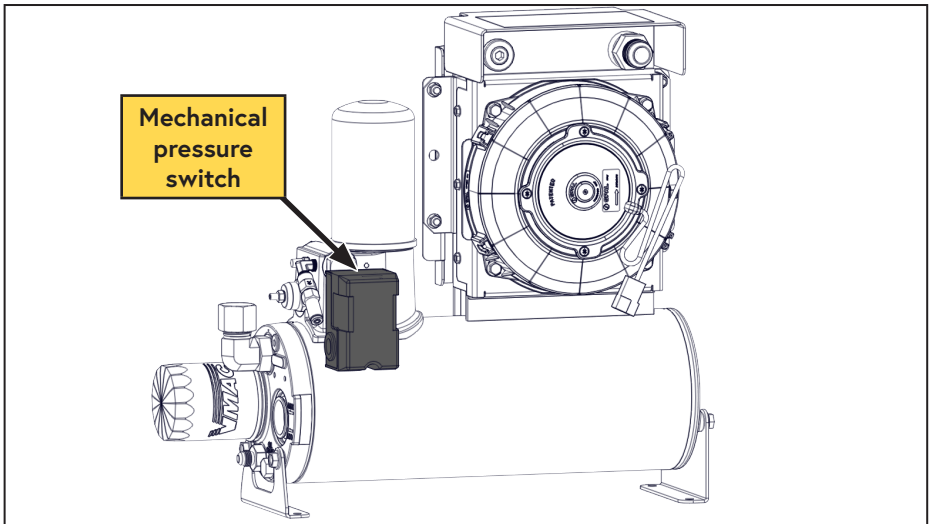

Figure 40 — WHASP Tank pressure switch

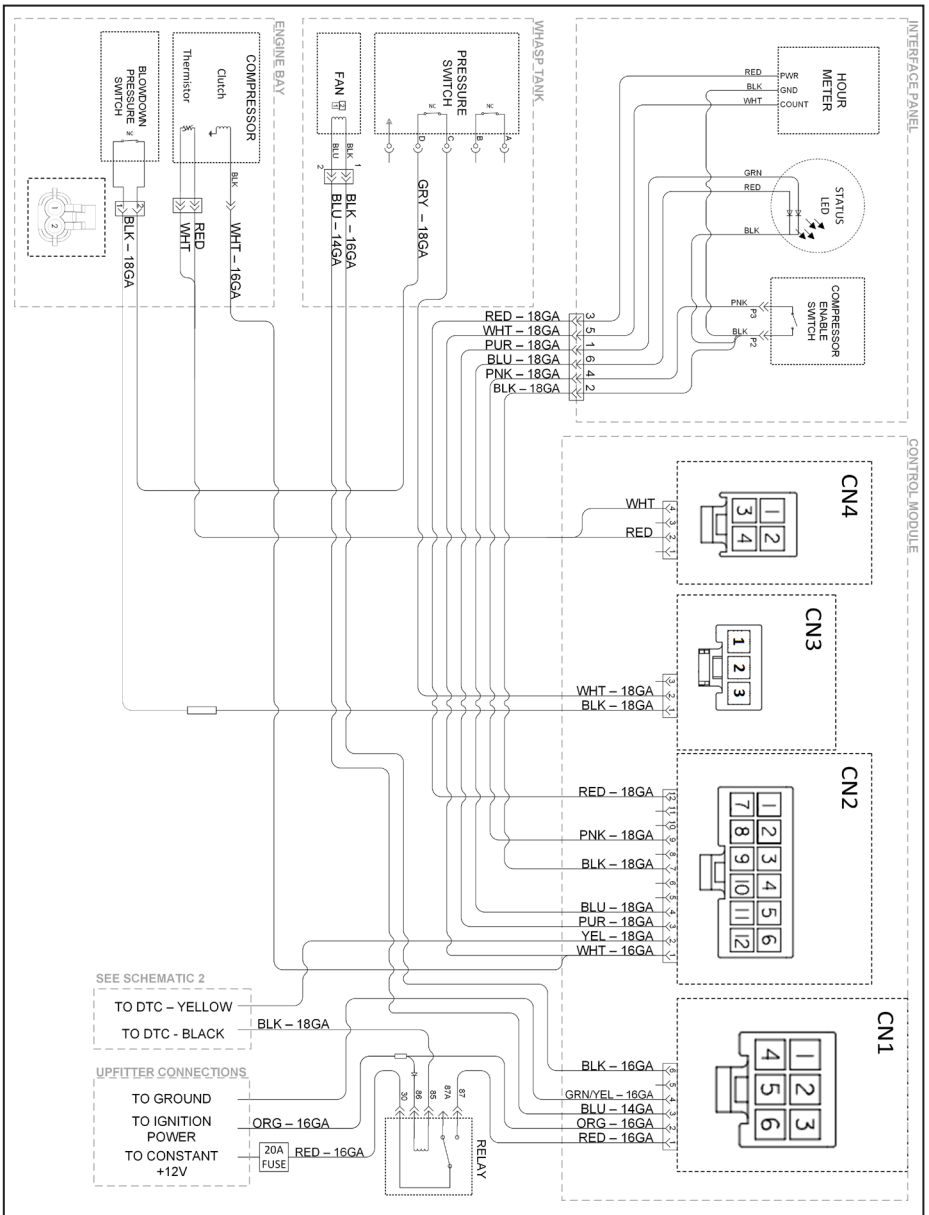

Figure 41 — Electrical schematic 1

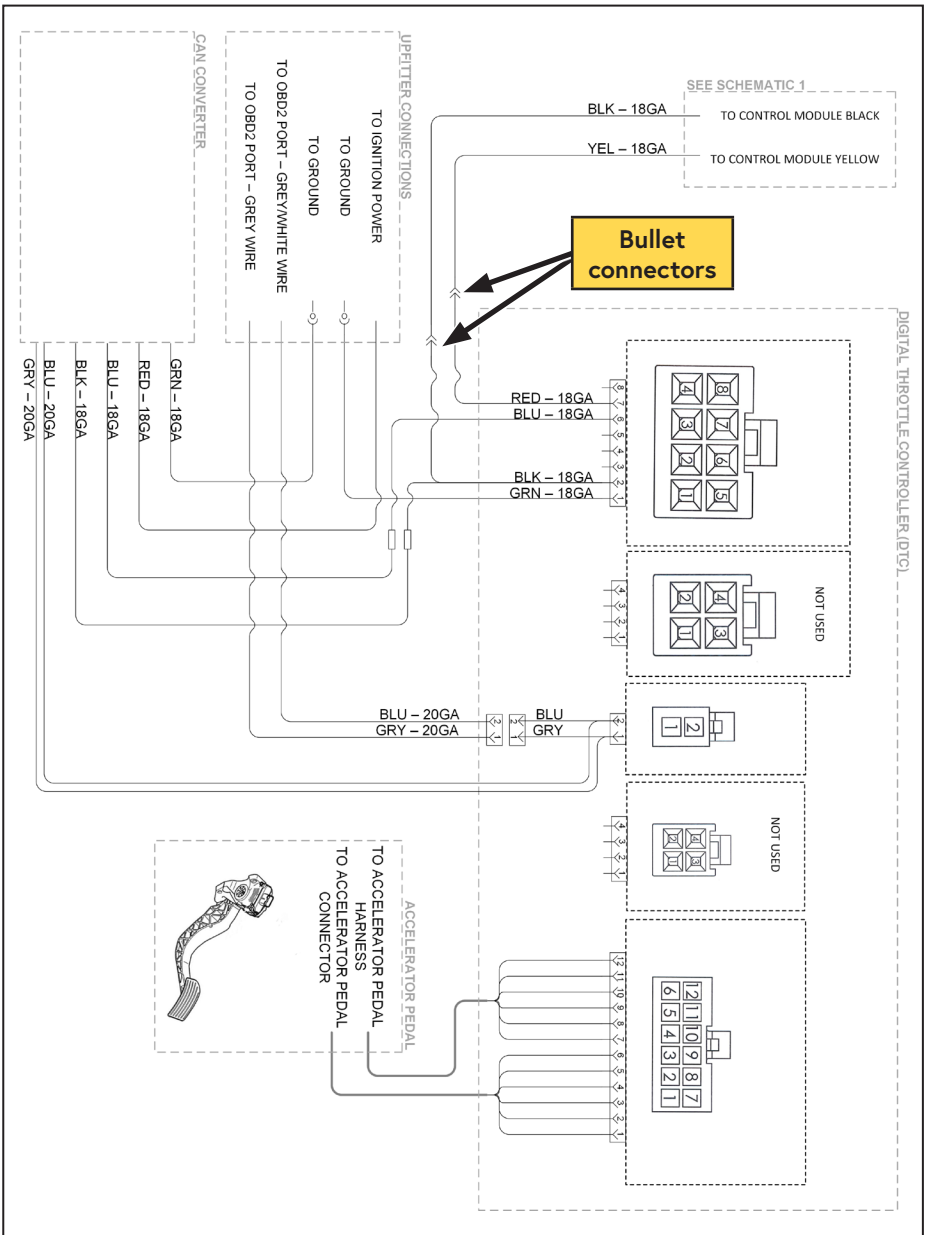

Figure 42 — Electrical schematic 2

Throttle Control

- Plug the (x3) harnesses into the throttle control.
- Plug the 2 pin connector from the throttle control into the can converter harness.
- Using cable ties, secure the throttle control, and CAN converter under the dashboard, next to the OBD II port. Ensure it is away from moving parts and positioned so that the buttons and LED lights are accessible.

Control Module

- Plug the (x4) harnesses into the control module.
- Mount the control module under the driver seat (Figure 43).

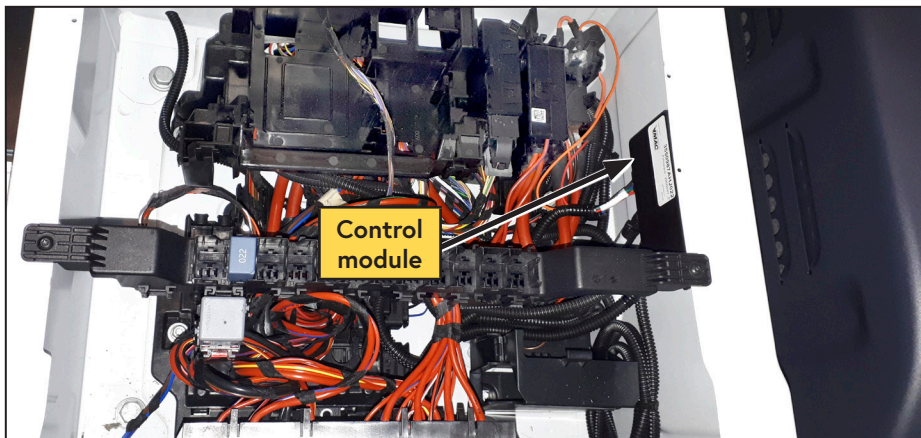

Figure 43 — Install control module

Connecting the Wiring

- Locate the (x3) terminal studs that serve as the electrical access point under the driver seat (Figure 44).

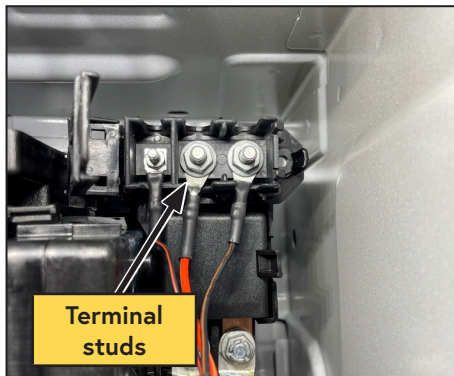
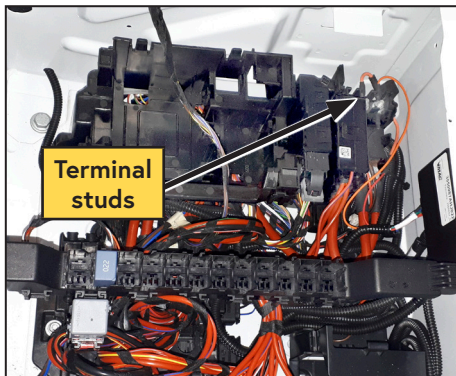

Figure 44 — Electrical access point

- Connect the yellow wire with bullet connector running from the control module to the red wire with bullet connector running from the throttle control (an extension wire has been included to accommodate longer routing options).

- Crimp the supplied fuse holder to the red wire running from the control module. Ensure the fuse holder is installed as close to the power source as possible.
- Connect the other end of the fuse holder to the terminal that holds the OEM with red wire with orange stripe (Figure 45).

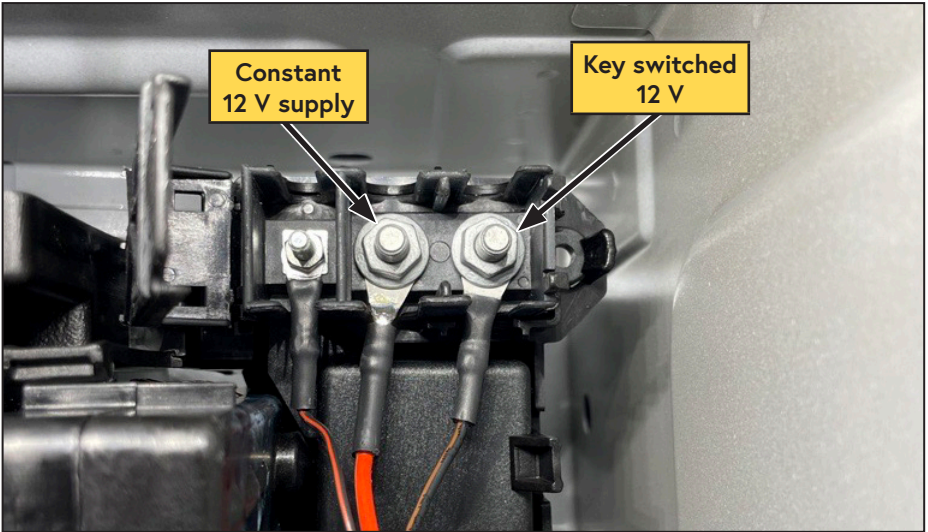

Figure 45 — Tie into vehicle power

- Connect the orange wire from the control module, and the red wire from the CAN converter, to the terminal that the OEM black wire with brown stripe is attached to (Figure 45).
- Unplug the OEM cable from the accelerator pedal and plug it into the matching connector from the throttle control. Plug the cable from the throttle control into the matching connector on the accelerator pedal.
- Splice the blue wire running from the CAN converter to the blue wire running from the throttle control.
- Splice the black wire running from the CAN converter to the black wire running from the throttle control.
- Connect the bullet connector on the black wire running from the control box to the power relay to the matching connector on the throttle control.
- Connect the ground wires (green wire) running from the throttle control, CAN converter, and control module to a good ground.

- Remove the side panel to gain access to the OBD II port (Figure 46).

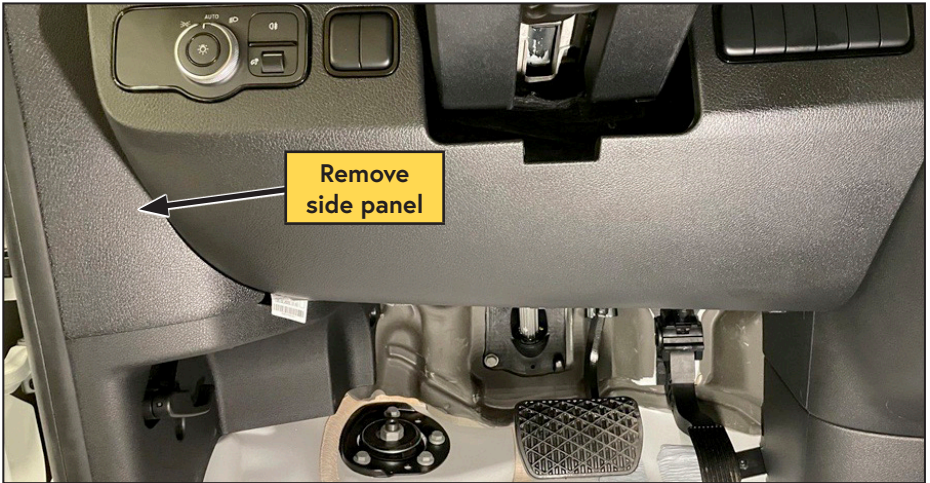

Figure 46 — Remove side panel

- Depress the (x4) clips in the OBD II connector and pull it out from the bottom to gain easier access to the wires.
- Peel back the tape on the harness a few inches.



Due to running OEM changes, the OBD II wire colours are subject to change without notice however, pins 6 (CAN high) and 14 (CAN low) are the standard and shall be the definitive method for determining the correct wire connections (the wires will be a twisted pair).

- Using the supplied Posi-Taps (see page 32), connect the blue wire from the throttle control to the wire at pin 6 (grey wire with white stripe at time of writing) of the of the OBD II port (Figure 47).

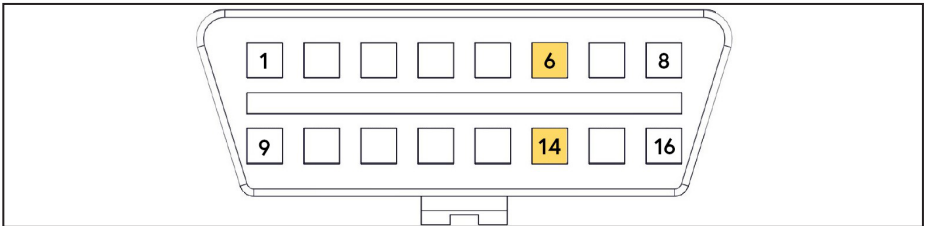

Figure 47 — OBD II connector

- Using the supplied Posi-Taps, connect the grey wire from the throttle control to the wire at pin 14 (grey wire at time of writing) connected to pin 14 of the OBD II port (Figure 47).

Route the following wires from the throttle control and control module through the grommet in the floor, beneath the driver seat*:

- *White 16 AWG wire from the control module (clutch wire).
- *Grey cable with the green connector from the control module (Temperature sensor).

Engine Bay Connections

- Cover all of the engine compartment wires with plastic loom.
- Route the grey cable and white wire running from the control module to the compressor along with the compressor hoses installed earlier and secure them with cable ties.
- Connect the green connector on the grey cable to the matching connector on the compressor.
- Connect the bullet connector on the white wire to the matching connector on the compressor.
- Connect the 2 pin connector on the pressure switch harness into the pressure switch.
- Connect the ring terminal on the green wire with yellow stripe to a good ground.
- Route the pressure switch harness (black 18 AWG, and grey 18 AWG wires) into the cab.
- Route the black 18 AWG wire running from the pressure switch harness to the control module.
- Using a butt splice supplied with the pressure switch harness, splice the black wire running from the pressure switch to the black wire running from pin 1 of the CN3 connector.
- Bundle the grey 18 AWG wire running from the pressure switch harness, the white wire running from the CN3 connector, the black and blue wire harness running from the CN1 connector, and the interface panel harness together.
- Route the bundled harnesses through the pass-through in the bulkhead to the cargo bay (Figure 48).

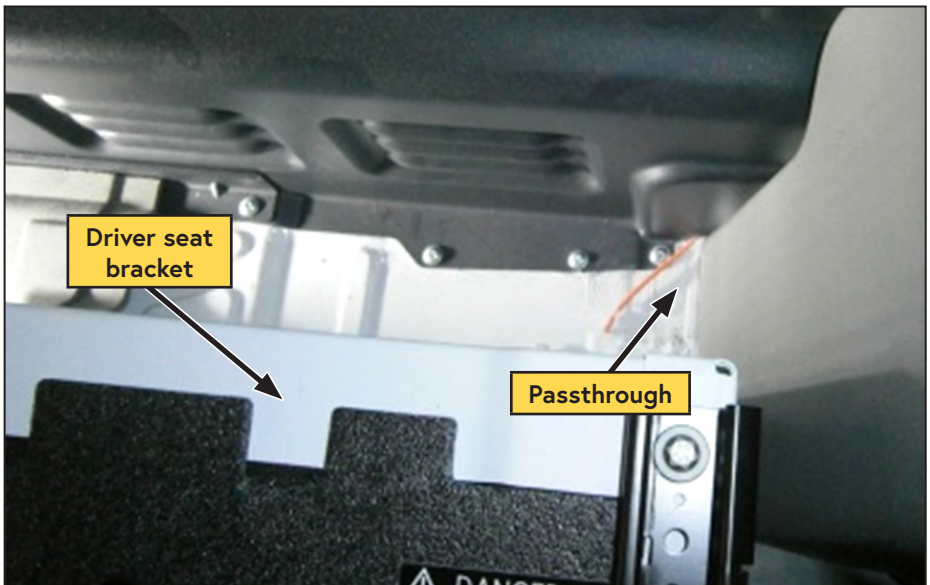

Figure 48 — Bulkhead passthrough

Interface Panel

- Install the interface panel in a suitable location (Figure 49).

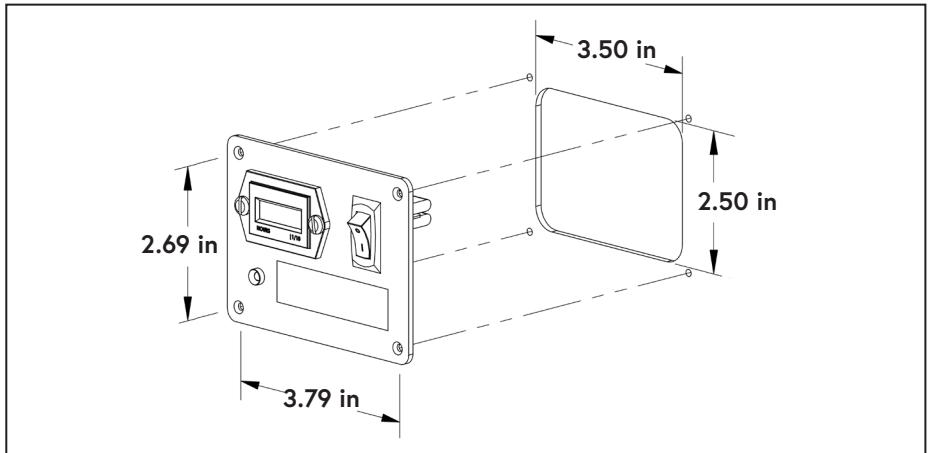

Figure 49 — Interface panel mounting dimensions

- Connect the harness from CN2 of control module to the interface panel.
- Connect the fan connector from CN1 of the control module to the plug on the WHASP Tank.
- Remove the cover from the WHASP Tank pressure switch.
- Connect the ring terminals from the white wire running from CN3 of the control module, and the grey wire running from the pressure switch harness to the pressure switch on the WHASP Tank (these are not polarity dependent) (Figure 50).

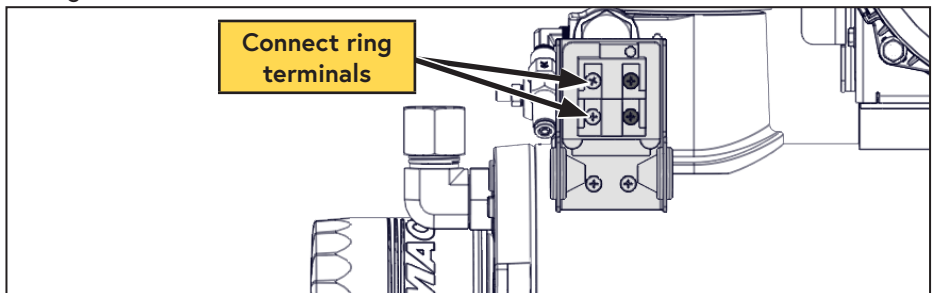

Figure 50 — Connect pressure switch

- Replace the WHASP Tank pressure switch cover.



The WHASP Tank harnesses are made to a generic length. Any excess harness should be coiled up and secured out of the way. There are 2 extra ring terminals included with the pressure switch harness; if desired, cut the harness to length and crimp the spare ring connectors to it.

- Ensure all wires and harnesses are protected with loom and routed away from sharp, hot, or moving components and away from high traffic areas.

Air Receiver Tank



Pressure in the air receiver tank will not be relieved when the compressor system blows down. This is normal operation. Prior to performing any service work on the system, discharge any stored air in the air receiver tank.



The VMAC WHASP Tank has a built-in check valve. Use of an additional check valve is not required and may cause erratic performance.



If an air receiver tank will be used with this system, the following installation procedure must be used to prevent damage to the system.

The VMAC compressor system will automatically depressurize when it is shutdown. The WHASP Tank has a built in check valve which prevents blow back and moisture from the receiver tank entering the WHASP Tank. Installation of an additional check valve will cause erratic performance.

While the air receiver tank can be installed at any height in relation to the WHASP, the discharge hose running from the WHASP must be installed as high as possible on the air receiver tank to prevent problems with condensation that may have accumulated in the receiver tank (Figure 51).

Drain the condensed water from the receiver tank daily.

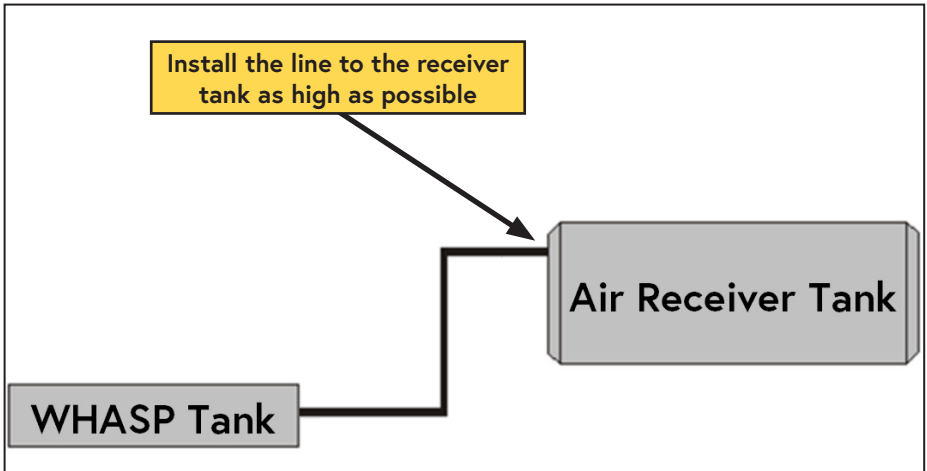

Figure 51 — Air receiver tank

Recommended Accessories

While the compressor system will function without the following accessories, VMAC strongly recommends their use for optimal performance.

See the "Accessory Product" section of this manual on page 54 for a list of products available for purchase through VMAC.

Receiver Tank

An air receiver tank provides a buffer as it gives the compressor time to react by increasing the engine speed and producing air before the tool stalls. It also has the advantage of lowering the duty cycle of the compressor system.

(This application requires a minimum air receiver tank size of 6 USG).

Pressure Gauge

While not critical to system performance, a pressure gauge is important for fine tuning the system and simplifies any potential troubleshooting.

Install a 200 psi pressure gauge downstream of the air discharge valve.

Pressure Regulator and/or Lubricator or FRL

The compressor can produce air pressures up to approximately 150 psi (1035 kPa). It is the responsibility of the user to know the pressure and air flow requirements of the tools powered by the air compressor system.

An appropriate air pressure regulator and lubricator can be installed downstream of the air discharge valve. Failure to regulate the air pressure may cause damage to the tool.

Completing the Installation

- Check all VMAC and OEM wiring to ensure that it will not contact any hot, sharp or moving components and will not interfere with the operation of the vehicle. Secure all wiring with rubber coated P-clips, cable ties and loom as required.
- Check all VMAC and OEM hoses and tubes to ensure that they will not contact any hot, sharp or moving components and will not interfere with the operation of the vehicle. Secure all hoses and tubes with rubber coated P-clips, cable ties and loom as required.
- Replace all dashboard panels.
- Replace the driver seat.
- Reconnect the battery(s).



The System Identification Plate must be attached to the vehicle at the time of installation. This plate provides information that allows VMAC to assist with parts and repairs.

- Locate a conspicuous area in the engine bay (where the tag will be easily noticed) to install the System ID tag.
- Mark and drill (x2) 7/64 in holes and secure the plate with the supplied self tapping screws (Figure 52).



Figure 52 — System Identification Plate

- To alert any technicians that may service the vehicle, affix the servicing caution/contact label in the engine compartment near the hood latch in a visible location (Figure 53).



Figure 53 — Advisory label

- Install the VMAC belt routing diagram in a suitable location under the hood (Figure 54).

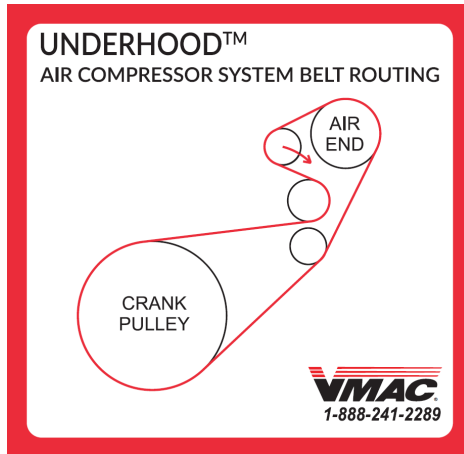

Figure 54 — Belt routing label
(actual belt routing label may differ)

- As part of the installation process, ensure that the safety and operational instruction decal is affixed in an obvious location so that it can be seen by vehicle operators. A good spot for this is usually on the inside of the door or on the panel underneath the steering wheel (Figure 55).

VMAC
VEHICLE MOUNTED AIR COMPRESSORS

This vehicle is equipped with a
VMAC Air Compressor System.

OPERATING INSTRUCTIONS

Daily Pre Start Check:

1. Check oil level in tank.
2. Check drive belt system.
3. Check for leaks.

Start Up Procedure:

1. Ensure air system is depressurized.
2. Ensure all air outlets are CLOSED.
3. Place vehicle in Neutral or Park and engage park brake.
4. Start engine and bring to operating temperature.
5. Turn ON compressor.

Shutdown Procedure:

1. Ensure discharge valve is CLOSED.
2. Allow engine to idle for 1 minute.
3. Turn OFF compressor.
4. Wait for system to depressurize before restarting.

For Technical Support/Parts contact your VMAC Dealer
To locate your nearest dealer call 1-800-738-8622 (250-740-3200)

4400644-A

⚠ WARNING
**Always allow system to
depressurize before restarting**

Figure 55 — Operating Instruction label

Testing the Installation



Lift the vehicle, ensuring the driven wheels are off of the ground. Support the vehicle securely with appropriately rated jack stands. Ensure there are no people around the vehicle before beginning the test.

If the vehicle fails the test, ensure the wiring to all of the connections are correct and secure. If additional assistance is required, contact your local VMAC dealer or call VMAC Technical Support 1-888-241-2289 or 250-740-3200.

Safety Test

Ensure the following has been completed:

- Place the transmission in "PARK" and apply the park brake. Turn the ignition key to "ON" but do not start the engine.
- Turn on the compressor and listen for the compressor clutch to engage.
- Observe the hour meter, and ensure the hourglass icon is blinking.
- Turn off the compressor switch and ensure the clutch has disengaged.

Before Starting the Engine Checklist

Ensure the following has been completed:

- Check that the compressor oil level at the tank sight glass is correct.
- Complete a final inspection of the installation to ensure everything has been completed.
- Perform a final belt alignment check.
- Check all wiring for security and protection. Ensure nothing is touching the compressor body.
- Ensure all of the compressor outlets are closed.
- Ensure the parking brake is engaged and the transmission is in "PARK".
- Start the engine.

After Starting the Engine Checklist

- Allow the vehicle to reach operating temperature.
- Turn on the compressor. The compressor clutch should engage, and the engine speed should increase in response to the throttle control. The vehicle's tachometer should indicate approximately 3,000 rpm.
- Once the engine speed reduces to base idle, turn off the compressor.
- Shut down the engine.
- Check the compressor oil level after the engine has been shut down and the oil level has had time to stabilize.



Ensure any stored air is drained from the system prior to adding oil.

- Add oil as necessary to bring the level to the "FULL" line in the sight glass and check for leaks.
- Install the VMAC Air Test Tool (P/N: A700052) with the 40 cfm (5/32 in) orifice installed and the ball valve closed.
- Start the engine. Assistance may be required for the next steps.



The following tests confirm that the drive disable system is working correctly. The drive disable system prevents the VMAC throttle from increasing engine rpm unless the transmission is in "PARK" and the park brake is engaged (it does not disengage the clutch!).

2 people are required to perform this safety test. 1 person must remain in the driver seat and be prepared to actuate the service (foot) brake if necessary.

The second person will actuate the compressor switch and ball valve as necessary.

- With the engine running and the vehicle in "PARK", release the parking brake. Turn on the compressor and open the ball valve.
 - The clutch should NOT engage, and the engine speed should remain at OEM base rpm.
 - The "STATUS" and "PRK BRAKE" LED's on the digital throttle control will turn off.
- Close the ball valve.
- Turn off the compressor.
- Reapply the park brake.



The steps marked with asterisks will be repeated.

- *With the engine running, depress the service (foot) brake and shift the transmission out of "PARK".
- *Turn on the compressor and open the ball valve.
 - *The clutch should engage, but engine speed should NOT increase.
 - *The "STATUS" and "PRNDL" LED's on the digital throttle control will turn off.
- *Close the ball valve.
- *Turn off the compressor.
- *Drain any accumulated air from the system.
- *Shift the transmission into "PARK".
- Repeat the steps marked with asterisks for all transmission selector positions, returning the gear selector to "PARK" and cycling the compressor "OFF", then "ON" after each gear is tested.



Engine speed should not increase unless the vehicle is in "PARK" or "NEUTRAL".

- Drain any air that may have accumulated during the previous tests.
- Ensure the parking brake is engaged.
- Turn on the compressor and open the ball valve.
- Release the park brake. The engine speed should drop to base idle.
- Close the ball valve.
- Turn off the compressor.
- Reapply the park brake.
- Shut down the engine.
- Drain any accumulated air from the system.

Final Testing

Ensure the following has been completed:

- Operate the system with an air tool (or the VMAC Air Test Tool with the appropriate orifice installed) for at least 1/2 hour (1 hour preferred).



The WHASP Tank cooling fan is thermostatically controlled, and may start or stop without warning.

- Road test the vehicle for approximately 20 km (14 miles).
- Observe the compressor while it is operating to ensure the belts rotate properly, pulleys rotate smoothly and nothing is rubbing or contacting hot parts.
- Check all components, connections and fasteners once the engine is turned off and the system has cooled.
- Check the coolant level after the engine has been operated.
- Check the compressor oil level after the engine has been shut down and the oil level has had time to stabilize.

Performance Testing

Compressor Performance Testing

This system has been adjusted at the factory for general operation, not maximum cfm. Any performance testing should be done with the throttle control set for maximum cfm. See the previous page for instruction on adjusting the throttle control.

System operation can be tested using the tools that will be operated by the system or by using the VMAC Test Tool (A700052) with the 40 cfm (5/32 in) orifice in the outlet to simulate tool use (Figure 56).

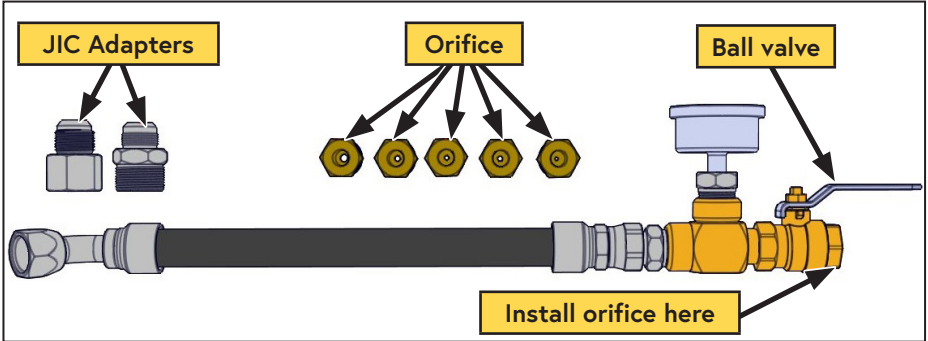

Figure 56 — A700052 VMAC Air Test Tool

Disconnect all downstream equipment (hose reels, etc.) and connect the test tool directly to the discharge fitting on the WHASP Tank. Ensure there are no leaks in the test tool. The system may not idle down if there are leaks in the lines or fittings.

- Install the VMAC test tool at the system outlet with the 40 cfm (5/32 in) orifice.
 - Ensure the ball valve is closed.
 - Place the transmission in "PARK" and fully apply the park brake.
 - Allow the engine to run until it is at operating temperature.
 - Turn on the air compressor system and allow it to operate until the oil is warm.
 - Observe the pressure gauge. Pressure should be approximately 150 psi.
- Open the ball valve on the test tool and observe the engine tachometer:
- Engine speed should increase to a maximum of 3,700 rpm.
 - The pressure on the gauge should be 90 - 120 psi.
- Close the air valve slowly to allow the system pressure to rise. When the pressure reaches the pressure switch set-point of 150 psi, the system will disengage the compressor clutch and reduce the engine speed to base idle.
 - Once the system pressure is at maximum pressure, slowly open the ball valve on the test tool until the pressure on the gauge begins to drop. Engine speed should ramp up to a maximum of 3,700 rpm when the pressure drops approximately 40 psi below the pressure switch set-point.

Digital Throttle Control Operation and Adjustments

The throttle control is configured at the factory for optimum performance at maximum cfm. In applications where maximum cfm is not required, or noise is a concern, the throttle control can be adjusted to reduce the maximum VMAC rpm.

Safety features

The throttle control has built in safety features that will disable the system if an unsafe condition is detected, or either of the lock out parameters is not met (the vehicle must be in "PARK" and the park brake must be engaged).

If an unsafe condition is detected, the "STATUS" LED will turn off, and engine speed will return to idle. Once all unsafe conditions have been removed, the system must be cycled off, then on again to reset it. Once the system powers up, the "STATUS" LED will illuminate, and the system will operate normally.

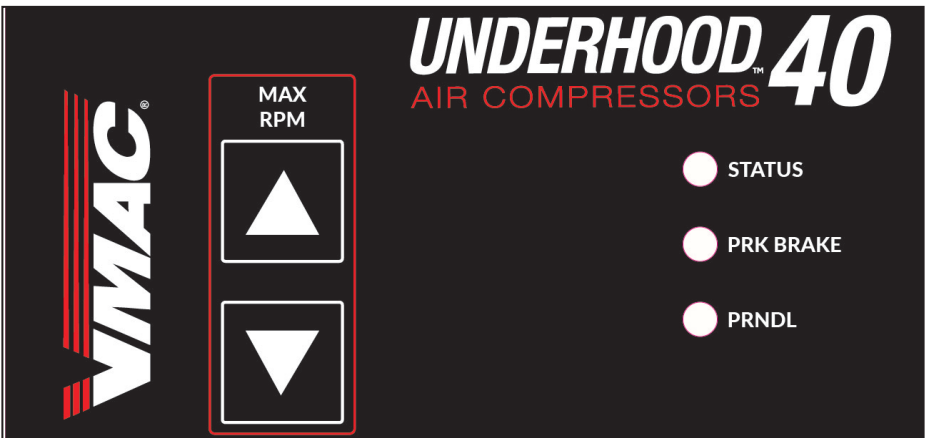

Figure 57 — Throttle control



If the vehicle is placed into gear, or the park brake disengaged, the "STATUS" LED and the "PRNDL" or "PRK BRAKE" LED will turn off and the throttle control will deactivate. This will reduce engine speed to base idle.

In order to activate the system again, re-engage the appropriate lockout and cycle the VMAC "OFF" then "ON" via the interface panel.



In order to perform a factory reset, or adjust the "MAX RPM", the throttle needs to be active and engine rpm elevated; VMAC recommends installing the VMAC Air Test Tool (P/N: A700052) with the 40 cfm (5/32 in) orifice. Turn the system on and open the ball valve, allowing the engine speed to increase.

MAX RPM

The cfm produced by the system is directly related to engine speed; this system delivers **34.5 cfm at 3,700 rpm.**

Maximum VMAC rpm can be adjusted between 1,500 rpm and **3,700 rpm** (in 50 rpm increments) via the "▲" or "▼" buttons in the "MAX RPM" column.

Factory Reset

The throttle control can be reset to factory default values via a button inside the throttle control box.

Using a paper clip (or similar object), push and hold the factory reset button for 5 seconds. All of the LED lights will illuminate for several seconds while the settings revert to their defaults. Once the LED's return to their normal state, the system is ready for use again (Figure 58).

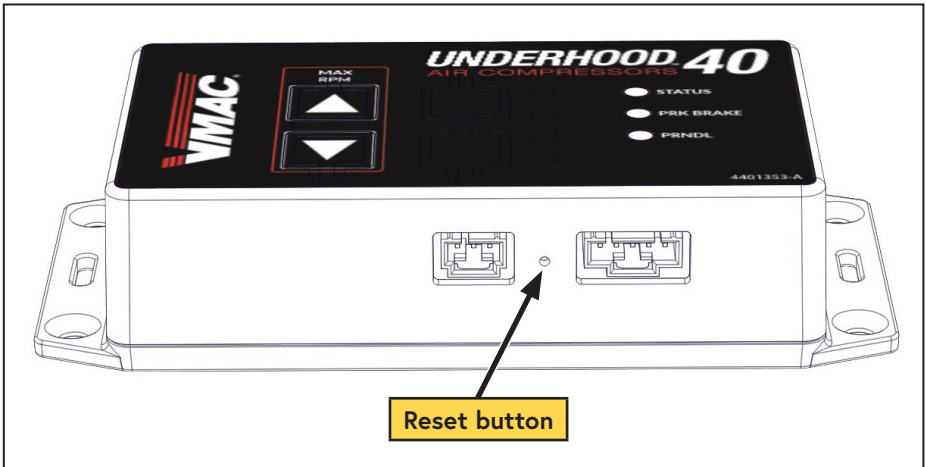

Figure 58 — Reset button

Accessory Products from VMAC

Compressor Service Kits



200 Hour or 6 Month Service Kit -

Part number: A700263

Includes 4 L VMAC high performance compressor oil, oil filter, air filter, and next service due decal.

400 Hour or 1-Year Service Kit -

Part number: A700264

Includes 4 L VMAC high performance compressor oil, oil filter, air filter, spin-on oil separator, safety valve, muffler, and next service due decal.

UNDERHOOD 70 Air Aftercooler

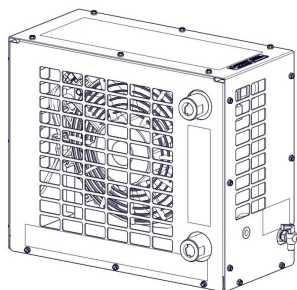

Part number: A800070

Improves tool performance and extends the life of air tools; removes up to 80% of water from compressed air; includes automatic water drain.

- Max air flow: 70 cfm / 175 psi.
- Port size: 3/4 in NPT inlet and outlet.
- Electrical: 12 V.
- Dimensions: 17 in (43.2 cm) L x 8.0 in (20.3 cm) W x 14.5 in (36.8 cm) H .
- Weight: 35 lb (15.8 kg).

Filter Regulator Lubricator (FRL) – 70 cfm

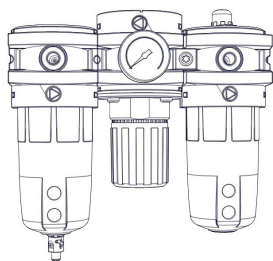

Part number: A700151

Extends the life of air tools; filter removes contaminants from the compressed air, adjustable regulator can reduce air pressure going to tools, lubricator adds atomized tool oil to the air stream to lubricate air tools (Tool oil not included).

- Max air flow: up to 70 cfm / 150 psi.
- Port size: 3/4 in NPT inlet and outlet.

1/2 in x 50 ft Hose Reel

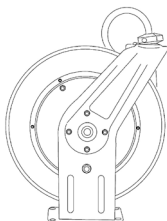

Part number: A700007

Spring-loaded 1/2 in x 50 ft hose reel; steel construction; full flow shaft and swivel for maximum performance.

Remote Muffler

Part number: A700224

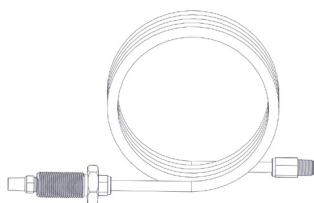

The A700224 WHASP remote mount muffler kit is designed to relocate the blowdown muffler to an external location. This is recommended for applications where the WHASP Tank will be located inside of a van or service body, the remote mounted muffler will reduce cabin noise when the compressor blowdown operates, and will ensure any oil vapor will be safely discharged outside of the vehicle.

Bulkhead Fittings

Part number: 3801504

Includes:

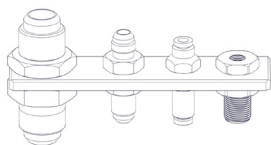

Bulkhead fittings are used for passing the system discharge, oil, and scavenge hoses through the floor or body panels.

- 3/4 in JIC bulkhead fitting P/N: 4900170.
- 3/8 in JIC bulkhead fitting P/N: 4900209.
- 1/8 in NPT bulkhead fitting P/N: 5000178.
- 1/4 in PTFE bulkhead fitting P/N: 5000240.
- Bulkhead mounting plate P/N: 1201228.

Hose Fittings

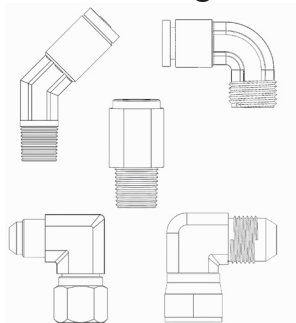

45° 1/4 push-to-connect fitting P/N: 5000158.

1/4 in push-to-connect fitting For PTFE scavenge tube.

90° 1/4 push-to-connect fitting P/N: 5000020.

1/4 in push-to-connect fitting For PTFE scavenge tube.

Straight 1/4 in push-to-connect fitting P/N: 5000012.

1/4 in push-to-connect fitting For PTFE scavenge tube.

90° 3/8 in hose fitting P/N: 4900117.

3/8 in hose fitting for Oil Return Hose.

90° 3/4 in hose fitting P/N: 4900043.

3/8 in hose fitting for Compressor Discharge Hose.

Interface Harness Extension

Part number: A700265

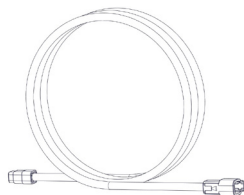

This interface harness extension provides an additional 10 ft of cable which allows for greater flexibility in locating the Interface Panel.

6 Gallon Air Receiver Wing Tank

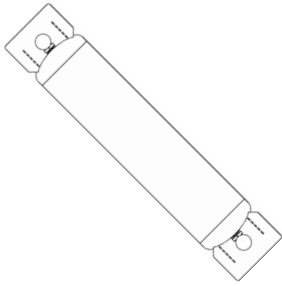

Part number: A300056

Air receiver tanks are used for lowering compressor duty cycle and removing water from compressed air; recommended for optimum operation of all VMAC Gas Driven, Diesel Driven, Hydraulic, and UNDERHOOD40 air compressors. Manufactured to FMVSS 121 standard; includes fittings, 170 psi pressure relief valve, and tank drain.

- Max pressure: up to 170 psi.
- Dimensions: 32 in (81.3 cm) L x 8 in (20.3 cm) D.
- Weight: 23 lb (10.4 kg).

10 Gallon Air Receiver Tank w/ Mounting Feet



Part number: A300047

Air receiver tanks are used for lowering compressor duty cycle and removing water from compressed air. Recommended for optimum operation of VMAC Hydraulic Air Compressors, VMAC Diesel Driven Air Compressors, UNDERHOOD40, UNDERHOOD70 – Green Series Air Compressors, and VMAC Multifunction Power Systems, which include standby mode; ASME certified; includes fittings, 200 psi pressure relief valve, tank drain, and 200 psi pressure gauge.

- Max pressure: up to 200 psi.
- Dimensions: 30 in (76.2 cm) L x 10 in (25.4 cm) D.
- Weight: 33 lb (15 kg).

35 Gallon Air Receiver Wing Tank

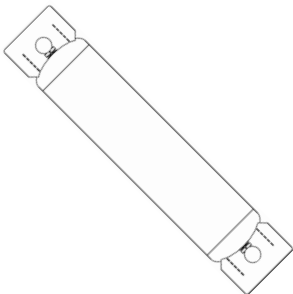

Part number: A300010

Air receiver tanks are used for lowering compressor duty cycle and removing water from compressed air. Recommended for optimum operation of VMAC Diesel Air Compressors, Hydraulic Air Compressors, UNDERHOOD40, UNDERHOOD70 – Green Series Air Compressors, and VMAC Multifunction Power Systems, which include standby mode; ASME certified; includes fittings, 200 psi pressure relief valve, tank drain, and 200 psi pressure gauge.

- Max pressure: up to 200 psi.
- Dimensions: 73 3/4 in (187.3 cm) L x 14 in (35.6 cm) D.
- Weight: 95 lb (43.1 kg).

Warranty Registration

This form must be fully completed and returned to VMAC at the time the vehicle is put into service. Warranty may be void if this form is not received by VMAC within 3 months of receiving the vehicle, or 200 hours of operation, whichever occurs first.



VMAC's Warranty policy and registration can be viewed online at:
www.vmacair.com/warranty

Product Information

System Identification Number: V _____

Compressor Serial Number: P _____

Owner / End User Information

Company Name: _____

City: _____ State / Province: _____

Phone: (____) ____-_____

Email Address: _____

Date vehicle was put into service: ____/____/____
Day Month Year

Installer Information

Installer Company Name: _____

City: _____ State / Province: _____

Submitted by

Name: _____ Phone: (____) ____-_____

Email: _____

Vehicle Information (Optional)

Unit: _____ Year: _____

Make: _____ Model: _____

Vehicle Identification Number: _____

Manufactured by



888-241-2289



tech@vmacair.com



877-740-3202



warranty@vmacair.com



www.vmacair.com



kb.vmacair.com



1333 Kipp Road, Nanaimo, B.C., V9X 1R3 Canada