

UNDERHOOD® **40** AIR COMPRESSORS



Installation Manual for VMAC System

V400044

With Advanced Digital Controls

2023+ Ford Transit

3.5 L Gas PFDI Duratec

VMACAIR.com

Table of Contents

Safety	3
Warranty	4
General Information.....	6
Component Identification and Overview.....	8
Preparing for Installation	11
Main Bracket and Compressor Installation	18
Waste Heat Air Separator Package (WHASP) Tank Installation	21
Bulkhead Fittings Installation.....	24
Hose Requirements	27
Hose Installation.....	28
Adding Oil to the System	35
Electrical Schematic	36
Harness Reference	37
Electronics and Control Component Installation	40
Telematics Integration (Optional)	51
Remote Start Integration (Optional)	52
Installing the Air Filter and Power Steering Reservoir.....	53
Completing the Installation	54
Air Receiver Tank.....	58
Recommended Accessories	59
Testing the Installation.....	60
Basic Operation.....	64
Performance Testing	66
System Adjustment, Optimization, and Basic Parameters.....	67
Errors and Error Codes.....	68
Accessory Products from VMAC.....	73
Warranty Registration.....	76

Document: 1930507
Changes and Revisions

Revision	Revision Details	Revised by	Checked by				Implemented
			Eng.		Tech.	Qual.	
			Mech.	Elec.			
B	ECN: 23-237 Update electrical routing.	MSP	CAM	N/A	MSP	LPH	25 Jan. 2024
C	ECN: 24-063 Add manual park brake information	MSP	N/A	ASE	MSP	LPH	9 Apr. 2024
<u>D</u>	ECN: 24-178 Update foot pedal harness warning.	MSP	N/A	<u>SRD</u>	<u>BDJ</u>	<u>TPK</u>	29 Oct. 2024

Additional Application Information

- Use of an air receiver tank (minimum 6 USG) is required with this application.
- 2023+ Ford Transit, 3.5 L Gas PFDI Duratec engine.
- For 3.5 L Ecoboost, refer to the V400039 system.
- Dual alternator vehicles must be converted to single alternator prior to proceeding with the VMAC installation.

Registered Trademarks

All trademarks mentioned in this manual are the property of their respective owners. VMAC's use of manufacturers' trademarks in this manual is for identification of the products only and does not imply any affiliation to, or endorsement of said companies.

Loctite®, **Loctite® 242** and **Loctite® 567** are registered trademarks of Henkel AG & Company KGaA.

Eaton Aeroquip® is a registered trademark of EATON AEROQUIP INC.

Ford® and **Duratec®** are registered trademarks of Ford Motor Company.

Posi-Tap™ is a trademark owned by Swenco® Products, Inc.

Important Information

The information in this manual is intended for certified VMAC installers who have been trained in installation and service procedures and/or for anyone with mechanical trade certification who has the tools and equipment to properly and safely perform the installation or service. Do not attempt installation or service without the appropriate mechanical training, knowledge and experience.

Follow all safety precautions. Any fabrication for correct fit in modified vehicles must follow industry standard "best practices".

Notice

Copyright © 2023 VMAC Global Technology Inc. All Rights Reserved. These materials are provided by VMAC for informational purposes only, without representation or warranty of any kind, and VMAC shall not be liable for errors or omissions with respect to the materials. The only warranties for VMAC products and services are those set forth in the express warranty statements accompanying such products and services, if any, and nothing herein shall be construed as constituting an additional warranty. Printing or copying of any page in this document in whole or in part is only permitted for personal use. All other use, copying or reproduction in both print and electronic form of any part of this document without the written consent of VMAC is prohibited. The information contained herein may be changed without prior notice.

Printed in Canada

VMAC - Vehicle Mounted Air Compressors
VMAC Technical Support: 888-241-2289
VMAC Knowledge Base: kb.vmacair.com

Safety

Important Safety Notice

The information contained in this manual is based on sound engineering principles, research, extensive field experience and technical information. Information is constantly changing with the addition of new models, assemblies, service techniques and running OEM changes. If a discrepancy is found in this manual, contact VMAC Technical Support prior to initiating or proceeding with installation, service or repair. Current information may clarify the issue. Anyone with knowledge of such discrepancies, who proceeds to perform service and repair, assumes all risks.

Only proven service procedures are recommended. Anyone who departs from the specific instructions provided in this manual must first ensure that their safety and that of others is not being compromised, and that there will be no adverse effects on the operational safety or performance of the equipment.

VMAC will not be held responsible for any liability, consequential damages, injuries, loss or damage to individuals or to equipment as a result of the failure of anyone to properly adhere to the procedures set out in this manual or standard safety practices.

Safety should be the first consideration when performing any service operations. If there are any questions concerning the procedures in this manual, or more information is required, please contact VMAC Technical Support prior to beginning work.

Safety Messages

This manual contains various warnings, cautions and notices that must be observed to reduce the risk of personal injury during installation, service or repair and the possibility that improper installation, service or repair may damage the equipment or render it unsafe.



This symbol is used to call attention to instructions concerning personal safety. Watch for this symbol; it points out important safety precautions, it means, "Attention, become alert! Your personal safety is involved". Read the message that follows and be aware of the possibility of personal injury or death. As it is impossible to warn of every conceivable hazard, common sense and industry standard safety practices must be observed.



This symbol is used to call attention to instructions on a specific procedure that if not followed may damage or reduce the useful life of the compressor or other equipment.



This symbol is used to call attention to additional instructions or special emphasis on a specific procedure.

Warranty

VMAC Standard Warranty (Limited)

For complete warranty information, including both VMAC Standard Warranty (Limited) and VMAC Lifetime Warranty (Limited) requirements, please refer to our current published warranty located at: www.vmacair.com/warranty



If you do not have access to a computer, please contact us and we will be happy to send you our warranty.

VMAC's warranty is subject to change without notice.

VMAC Lifetime Warranty (Limited)

A VMAC Lifetime Limited Warranty is offered on the base air compressor only and only on UNDERHOOD, Hydraulic Driven, Transmission Mounted, Gas and Diesel Engine Driven Air Compressors, Multifunction Power Systems, and other products as defined by VMAC, provided that (i) the purchaser fully completes and submits a warranty registration form within 3 months of purchase, or 200 hours of operation, whichever occurs first; (ii) services are completed in accordance with the Owner's Manual; (iii) proof of purchase of applicable service kits are made available to VMAC upon request.



The VMAC Lifetime Warranty is applicable to new products shipped on or after 1 October, 2015.

Warranty Registration

The VMAC warranty registration form is located near the back of this manual. This warranty registration form must be completed and sent to VMAC at the time of installation for any subsequent warranty claim to be considered valid.

There are 4 ways the warranty can be registered with VMAC:



www.vmacair.com/warranty



warranty@vmacair.com



(877) 740-3202



VMAC - Vehicle Mounted Air Compressors
1333 Kipp Road, Nanaimo, BC, Canada V9X 1R3

VMAC Warranty Claim Process



VMAC warranty work must be pre-authorized by VMAC. Claims are processed via our dealer network. If you are not a VMAC dealer, please select one to work with via our Dealer Locator:
<https://www.vmacair.com/dealer-locator/>



- 1) Communicate with VMAC Technical Support at [\(888\) 241-2289](tel:8882412289) or tech@vmacair.com to help diagnose/troubleshoot the problem prior to repair. VMAC technical support will require the VMAC System ID, and hours on the compressor.
- 2) VMAC will provide direction for repair or replacement of the failed components.
- 3) If requested, failed parts must be returned to VMAC for evaluation.
- 4) Dealers may login to the VMAC website to view the "VMAC Labour Time Guide" (under "Agreements") to see the allowable warranty labour times.
- 5) Warranty invoices must include the Service Ticket number, VMAC System ID#, hours on the compressor, and a detailed description of the work performed.
- 6) VMAC Warranty does not cover consequential damages, loss of income, overtime charges, mileage, travel time, towing/recovery, cleaning or shop supplies.
- 7) Dealers submit warranty claims on behalf of the Vehicle Owner/End User affected by the defective part(s). The dealer ensures that all warranty credits are refunded back to the Vehicle Owner/End User who made the initial warranty claim.



In order to qualify for Lifetime Warranty (Limited), the completed warranty registration form must be received by VMAC within 3 months of the buyer receiving the Product(s), or 200 hours of operation, whichever occurs first.

If the completed warranty registration form has not been received by VMAC within 3 months of the buyer receiving the Product(s), or 200 hours of operation, the "Standard" warranty period will be deemed to commence 30 days from the date of shipment from VMAC.

Failure to follow the warranty claim process may result in denial of the warranty claim.

VMAC Product Warranty Policies & Warranty Registration can be found on the VMAC website (see previous page for URL).

General Information

Optional Equipment Compatibility

While VMAC strives to design systems compatible with optional OEM equipment (such as running boards), it is impractical to develop systems that accommodate every OEM and aftermarket option or add-on. Whenever possible, VMAC endeavors to advise of compatibility issues in the "Additional Application Information" section of the manual. Even when specific optional equipment is determined by VMAC to be incompatible, it does not preclude the vehicle upfitter or end user from modifying the optional equipment to make it compatible with the installed VMAC system. VMAC does not warranty or accept responsibility or liability for the fitment, function or safety of any products modified in any way not expressly outlined in the installation manual.

Before Starting



Note and label all parts that are removed from the vehicle as many of the OEM parts will be reused during the installation of the VMAC system.

Read this manual prior to beginning the installation to ensure familiarity with the components and how they will fit on the vehicle. Identify any variations from the application list such as vehicle model, engines, or optional equipment (e.g., dual alternator, active steering assist, etc.).

Open the package, unpack the components and identify them using the Illustrated Parts List (IPL) included in the Fastener Pack.

Hose Information

Depending on other installed equipment, it might be necessary to move the air/oil separation tank from its intended location. The hoses used in VMAC compressor systems have a specific inner liner that is compatible with VMAC compressor oil. Use of hoses other than those supplied or recommended by VMAC may cause compressor damage and may void your warranty. Replacement hoses can be ordered from a VMAC dealer or sourced locally. Refer to this Knowledge Base article for compatible hoses: [EXT-ALL-010-Required-VMAC-Hoses.pdf](#)

Ordering Parts

To order parts, contact a VMAC dealer. The dealer will ask for the VMAC serial number, part number, description and quantity. Locate the nearest dealer online at www.vmacair.com/dealer-locator or call (877) 912-6605.



Special Tools Required

- 15 mm serpentine belt wrench.

Torque Specifications

All fasteners must be torqued to specifications. Use manufacturers' torque values for OEM fasteners.

The torque values supplied in Table 1 are intended for VMAC supplied components, or for use as a guide in the absence of a torque value provided by an OEM.



Apply Loctite 242 (blue) to all fasteners (except nylon lock nuts) unless otherwise stated.

Torque values are with Loctite applied unless otherwise specified.

Standard Grade 8 National Coarse Thread								
Size (in)	1/4	5/16	3/8	7/16	1/2	9/16	5/8	3/4
Foot pounds (ft•lb)	9	18	35	55	80	110	170	280
Newton meter (N•m)	12	24	47	74	108	149	230	379
Standard Grade 8 National Fine Thread								
Size (in)	3/8	7/16	1/2	5/8	3/4			
Foot pounds (ft•lb)	40	60	90	180	320			
Newton meter (N•m)	54	81	122	244	434			
Metric Class 10.9								
Size (mm)	M6	M8	M10	M12	M14	M16		
Foot pounds (ft•lb)	4.5	19	41	69	104	174		
Newton meter (N•m)	6	25	55	93	141	236		

Table 1 — Torque Table

Component Identification and Overview

Electrical Modules

- Ensure the Digital Throttle Control (DTC) and Control Module (Controller) are mounted away from the pedals, park brake mechanism, or where they could be inadvertently knocked by occupants.
- The DTC throttle pedal harness cannot be modified, ensure the DTC is mounted close to the throttle pedal.
- The display box is not weather proof; ensure it is mounted where it will be protected from rain, snow, mud, direct sunlight, and or where it could be inadvertently knocked by occupants, etc. (e.g. inside the cab, service body or cabinet).

Control Components Overview

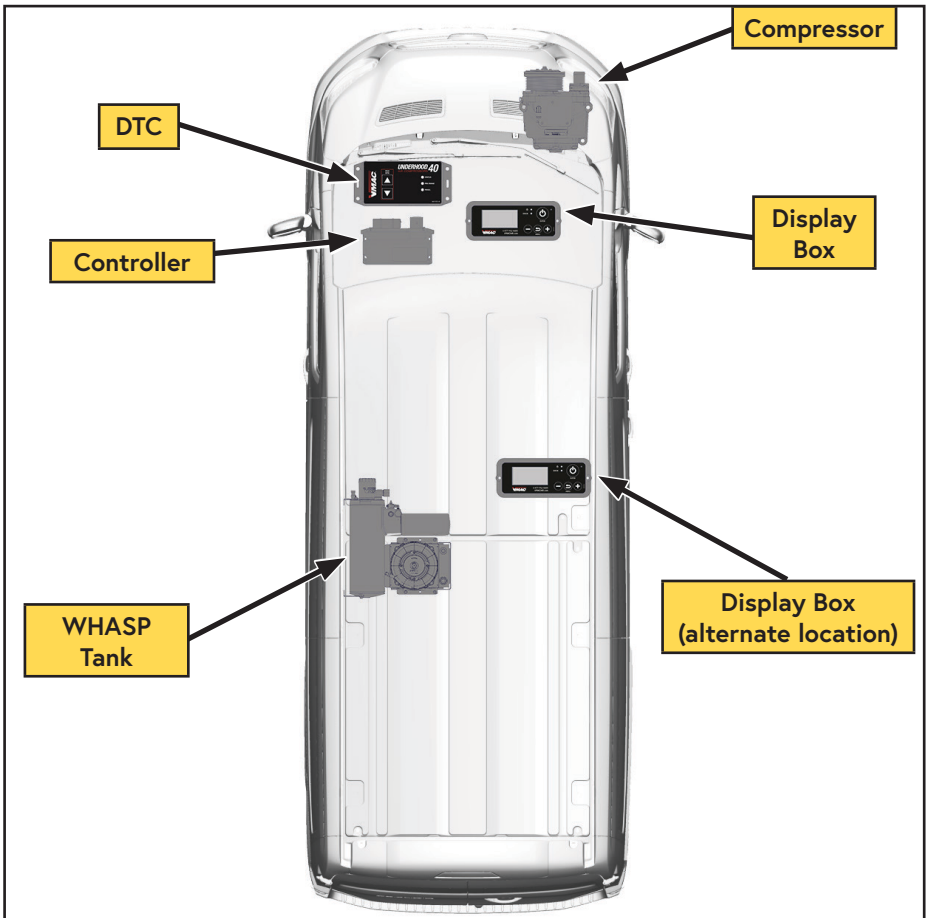

Figure 1 — General component overview
(Actual installation locations may vary)

Control Module (Controller) (Figure 2)

The control module serves as the primary input/output interface between the vehicle and the various VMAC components (compressor, DTC, WHASP Tank, Display Box, etc.).

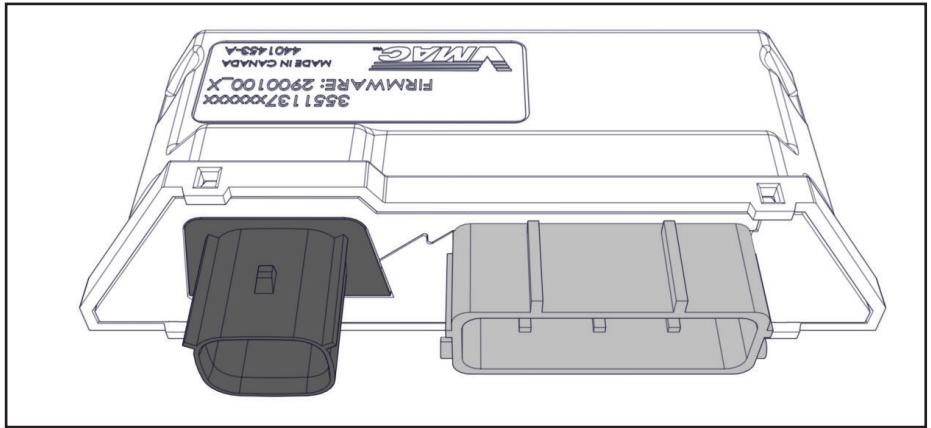

Figure 2 — Control module

Display Box (Figure 3)

The display box serves as the operator's control panel and contains the "ENTER" (compressor on/off), "-" (decrease), "MENU", and "+" (increase) buttons, power and "ERROR" indicator LEDs, and the screen. The screen includes information such as compressor hours, service reminders, warning messages, error codes, access to the advanced settings, and diagnostic information.

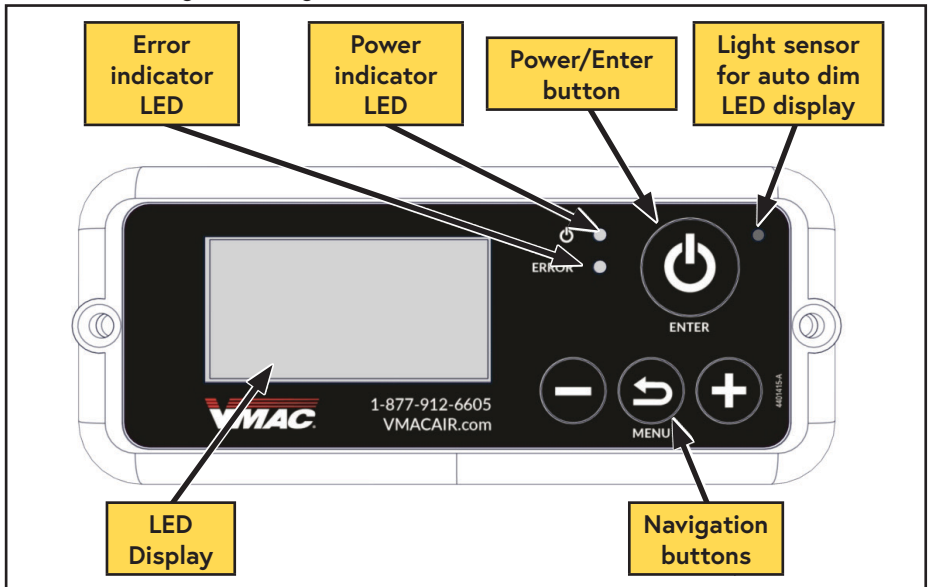

Figure 3 — Display box

Digital Throttle Control (DTC) (Figure 4)

The DTC responds to signals from the control module and commands the vehicle's throttle to increase or decrease engine speed in response to air demand.

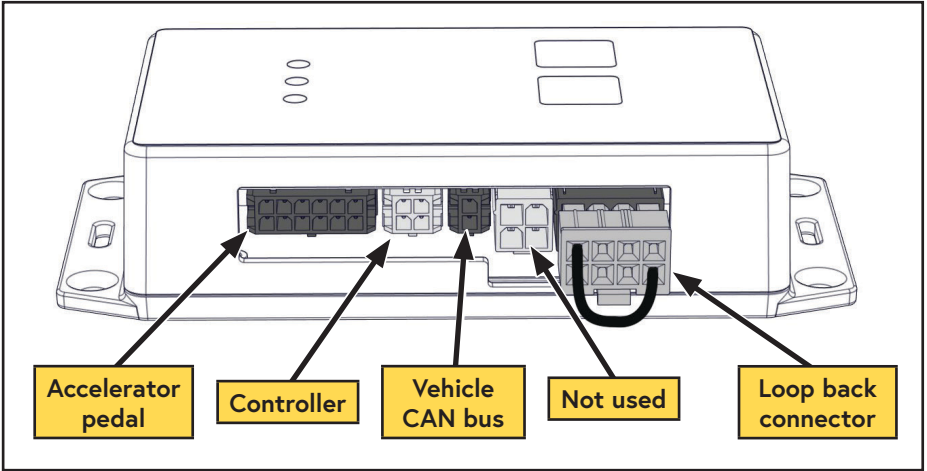

Figure 4 — VMAC DTC

Pressure Sensor (Figure 5)

The system pressure sensor is mounted on the side of the WHASP tank and measures the system pressure. The clutch will disengage once system pressure is achieved.

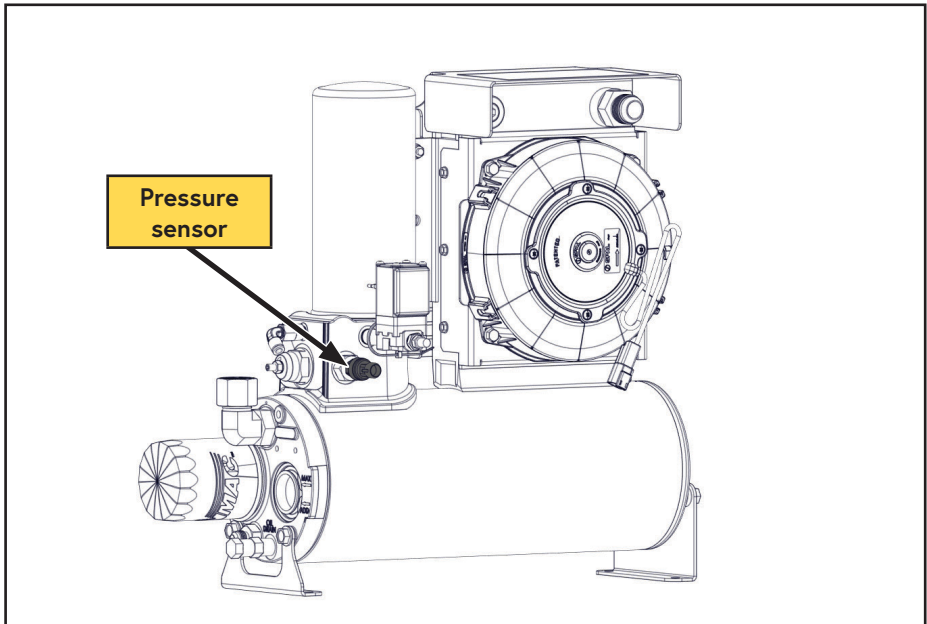

Figure 5 — WHASP Tank pressure sensor

Preparing for Installation



Preparation for installation is very important. Missing a step or an item can cause problems in the installation or damage to components.

Check off each item as it is completed so that no steps are missed.

- Review the contents of the system using the illustrated parts list to ensure all components are present and in the correct quantity. If any components are missing, have the system ID ready and call VMAC Technical Support at (888) 241-2289.



Dual alternator vehicles must be converted to single alternator prior to proceeding with the VMAC installation.



Prior to proceeding, ensure "Transport Mode" has been deactivated (contact a local Ford dealership or refer to the vehicle's owner's manual for instructions).

- Move the driver seat completely to the rear and remove the (x2) front fasteners (Figure 6).



Figure 6 — Driver seat (front)

- Move the driver seat completely forward and remove the (x2) rear fasteners (Figure 7).

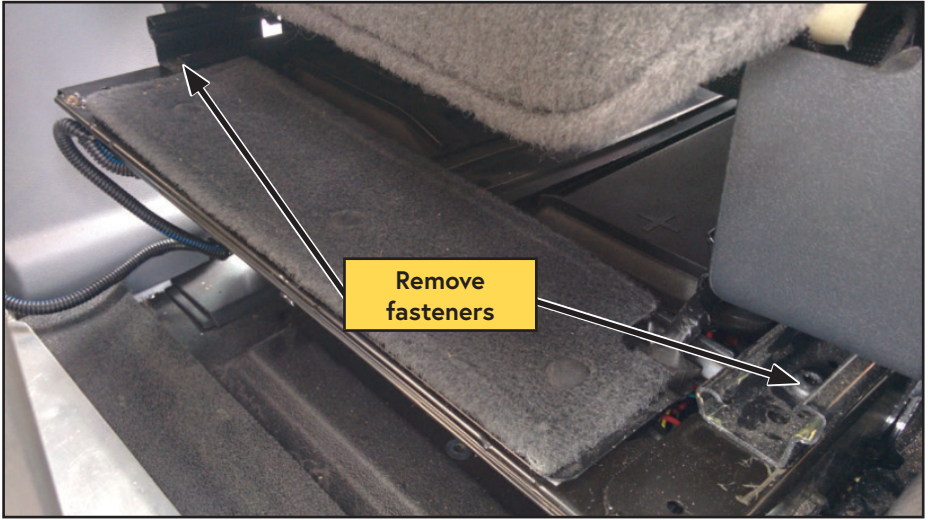

Figure 7 — Driver seat (rear)

- Remove the seat electrical connector (Figure 8).



Figure 8 — Seat electrical connector

- The seat electrical harness is hooked to a stud on the bottom of the seat. Ensure the harness is unhooked and the wire can hang loose under the seat.
- Leave the seatbelt connected to the seat and lift the seat off of its mount; place the seat on the floor outside of the driver side of the van.



The driver seat is heavy, use care when lifting it to prevent injury.

- ❑ Remove the (x2) bolts underneath the piece of carpet at the rear of the battery cover retaining plate. Remove the metal bracket, then lift the plastic tabs on the rear of the battery cover to remove the battery cover (Figure 9).

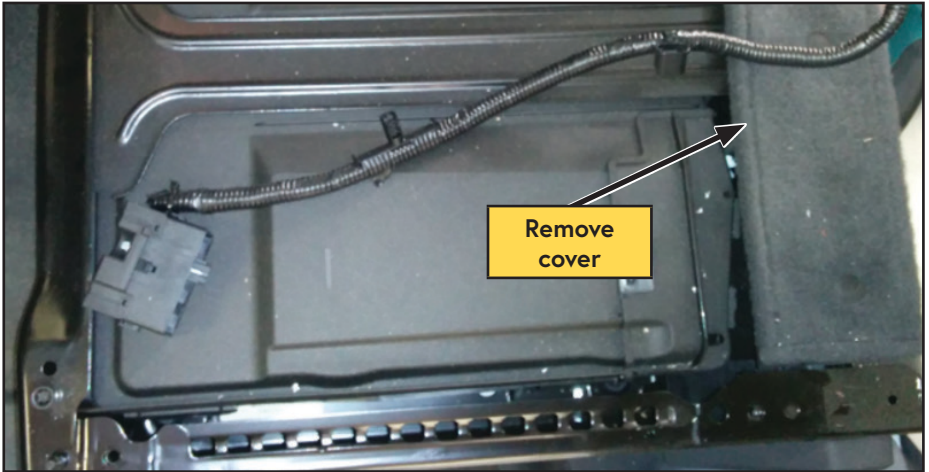

Figure 9 — Battery cover

- ❑ Disconnect the negative battery cable(s) from the battery terminal stud (Figure 10).

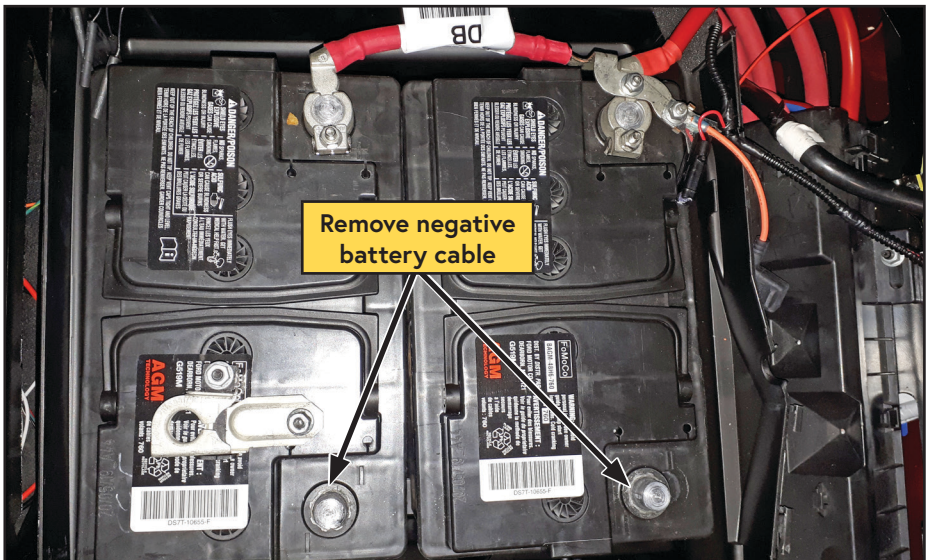

Figure 10 — Battery cables

- ❑ Remove the center console or step guard.

- Optional:** Remove the passenger side headlight and set it aside (this greatly improves access).
- To provide better access to the tensioner bolt, remove the (x2) coolant valve fasteners and shift the coolant valve out of the way (Figure 11).

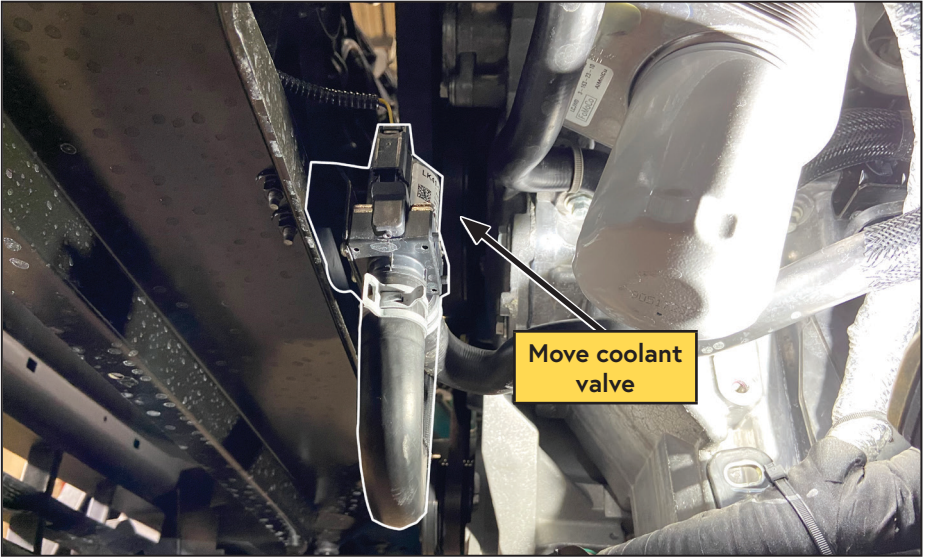

Figure 11 — Access tensioner bolt

- From underneath the vehicle, use a 15 mm serpentine belt wrench to release the tension and remove the OEM 6 rib belt from the crank pulley. Tuck the belt out the way (Figure 12).

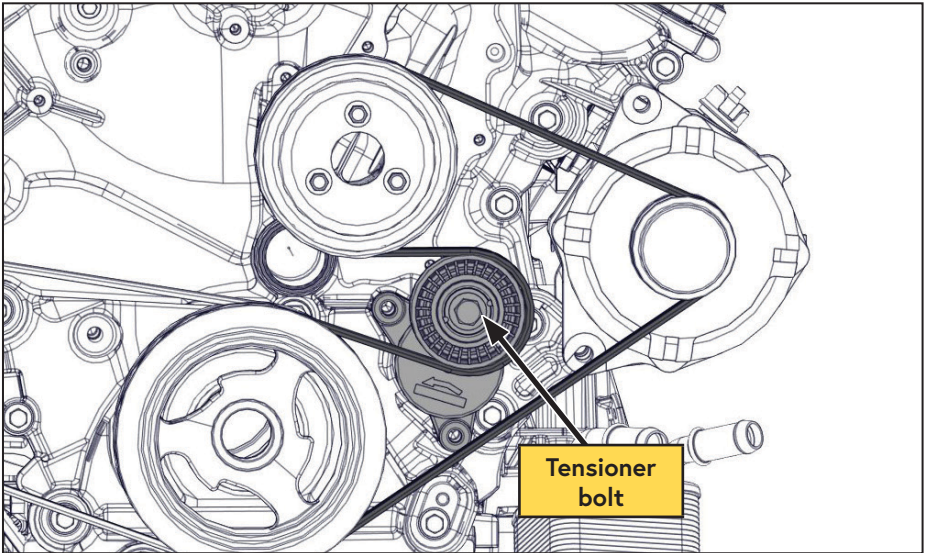

Figure 12 — Remove 6 rib belt



The stretch fit A/C compressor belt is not reused and can be cut to save removal time.

- Vehicles that have been converted to single alternator, skip this step:**
Remove the stretch fit A/C compressor belt (Figure 13).

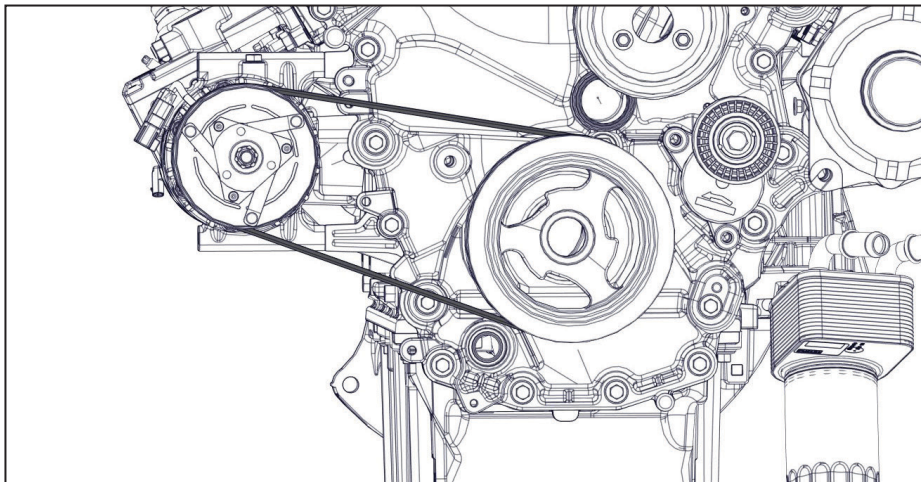

Figure 13 — Remove 4 rib belt



Ecoboost engine shown, the Duratec engine will be similar.

- Remove the bolt and Christmas tree fastener from the driver side cable tray and set them aside for later (Figure 14).

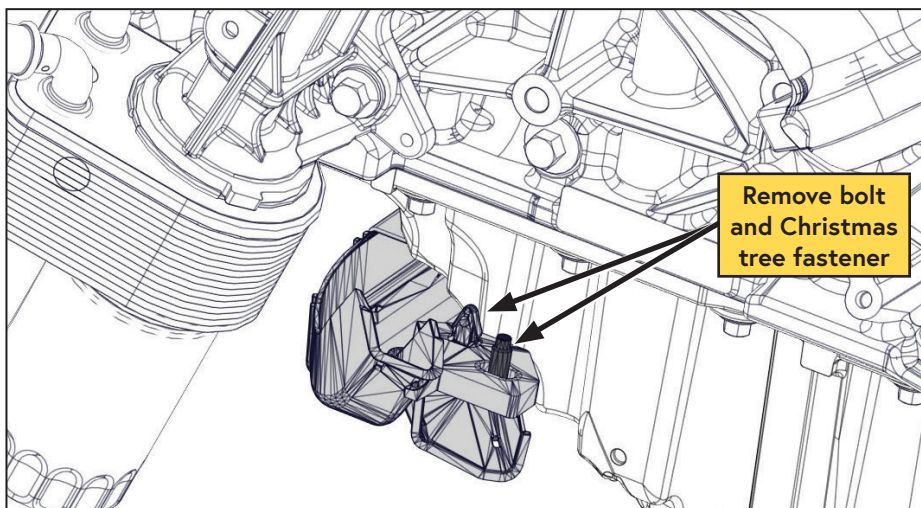

Figure 14 — Remove cable tray

- Remove and discard the stud securing the passenger side of the cable tray. Pull the tab off the mounting stud and push the wiring harness out of the way (Figure 15).

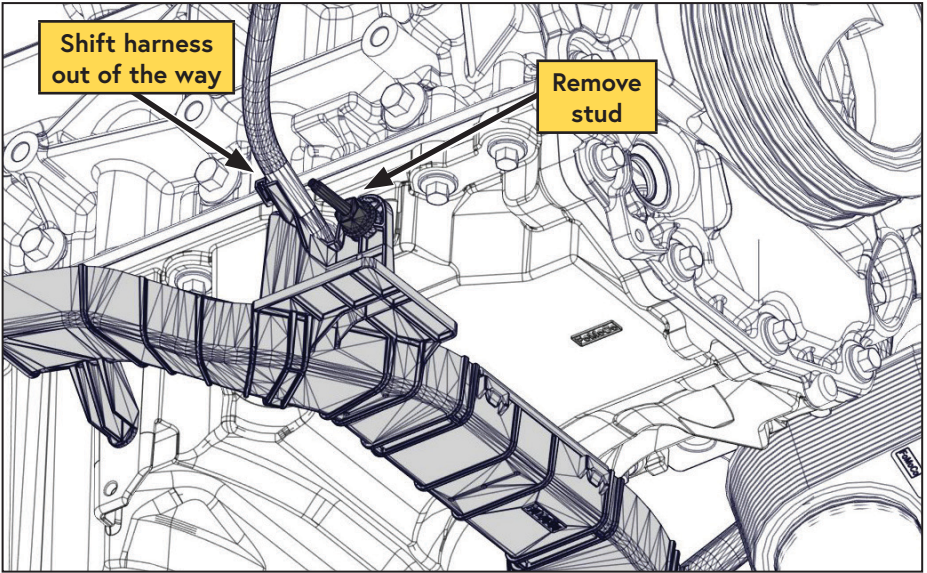

Figure 15 — Remove cable tray

- Remove and discard the timing cover bolts (Figure 16).

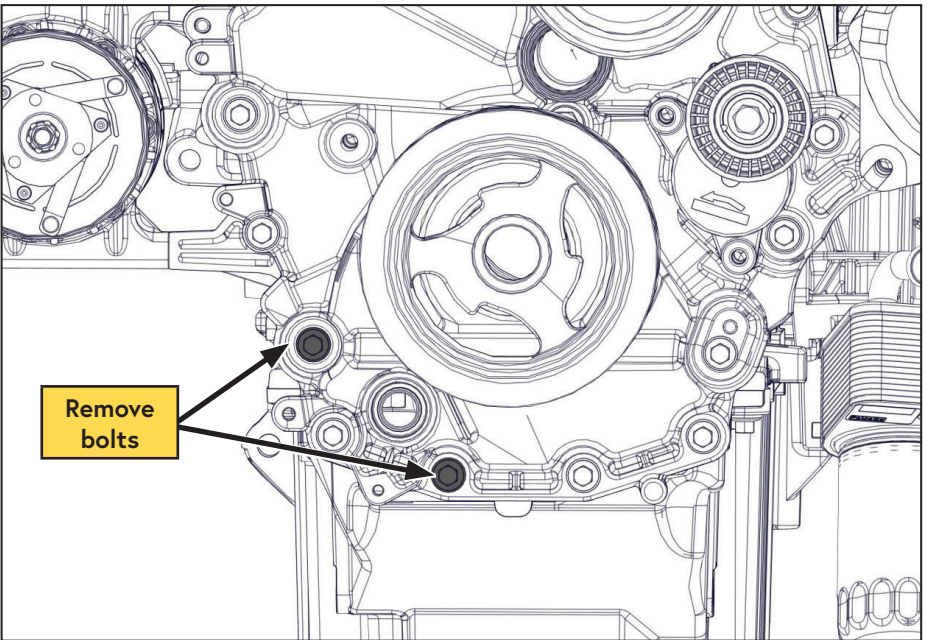

Figure 16 — Remove timing cover bolts

- Disconnect the electrical connectors from the A/C compressor.



Use caution when working around A/C system as excessive or repeated bending of the A/C lines can cause them to weaken or rupture.

Exposure to refrigerant can cause serious injury or death.

- Leaving the A/C lines connected, remove the A/C compressor and secure it up and out of the way (Figure 17).

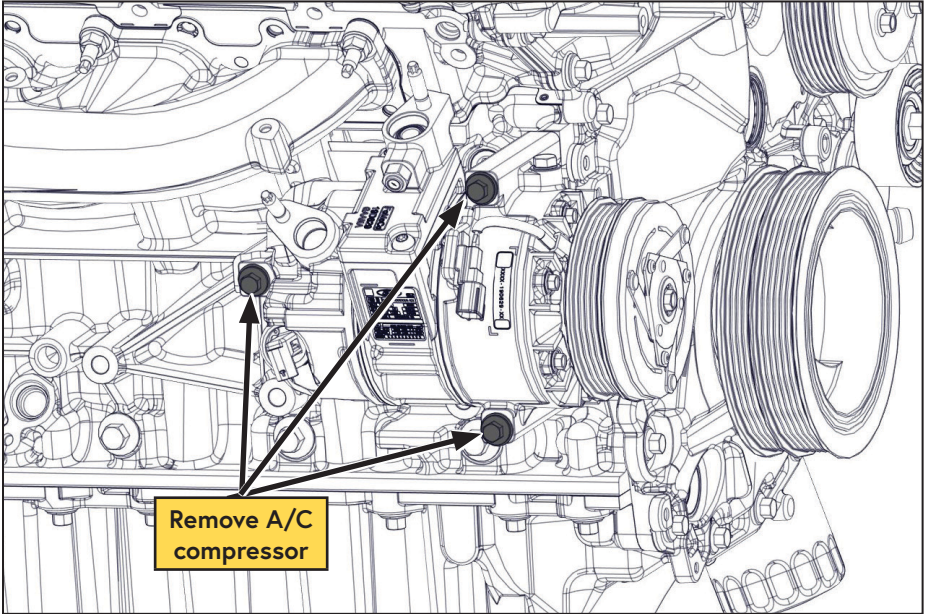

Figure 17 — Remove A/C compressor

Main Bracket and Compressor Installation

- Using the supplied fasteners, mount the main bracket onto the engine (Figure 18).

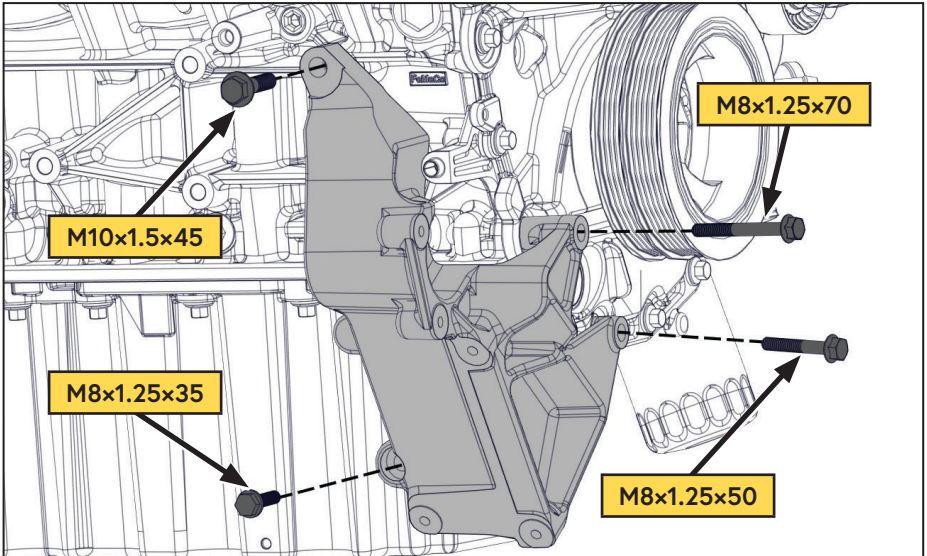

Figure 18 — Install main bracket

- Reinstall the A/C compressor onto the engine.
- Using the (x2) supplied M8x1.25x50 mm bolts, install the 4 rib belt tensioner onto the VMAC main bracket (Figure 19).

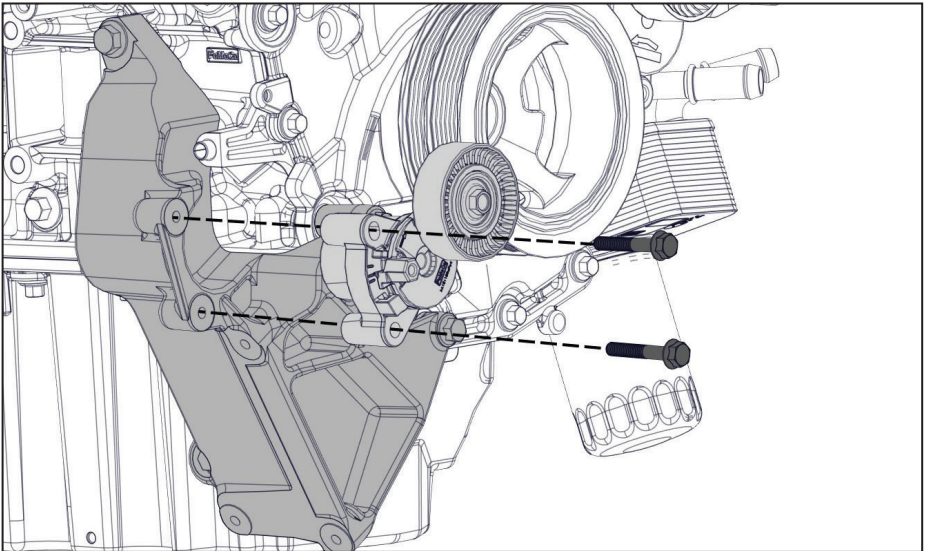

Figure 19 — Install tensioner

- Reconnect the A/C electrical connectors.
- Slide the pressure sensor assembly into the P-clip and mount it to the bracket using the supplied M6×14 mm bolt, and M6 nut (Figure 20).

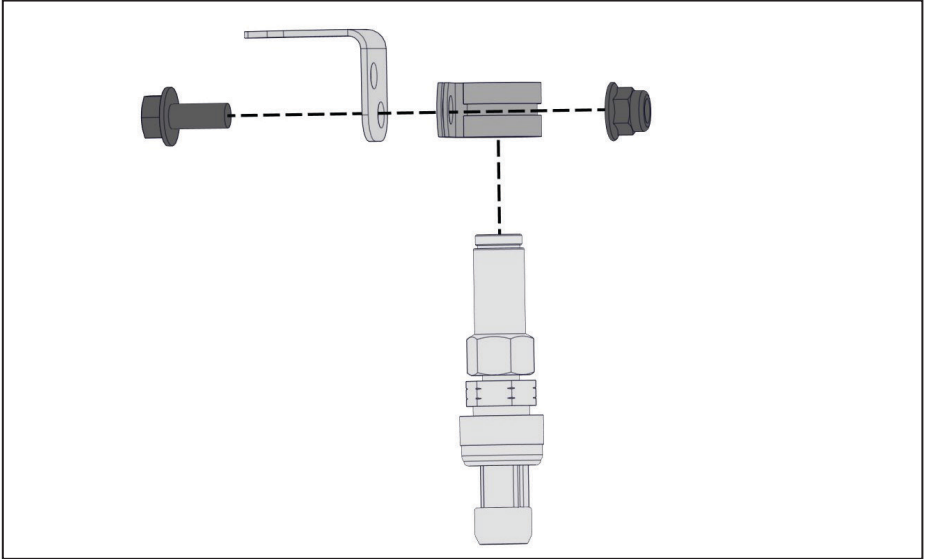

Figure 20 — Mount compressor

- Using the (×3) supplied M8×1.25×35 mm bolts, mount the compressor assembly, shorter cable tray bracket, and the pressure sensor assembly (in the orientation shown) onto the main bracket (Figure 21).

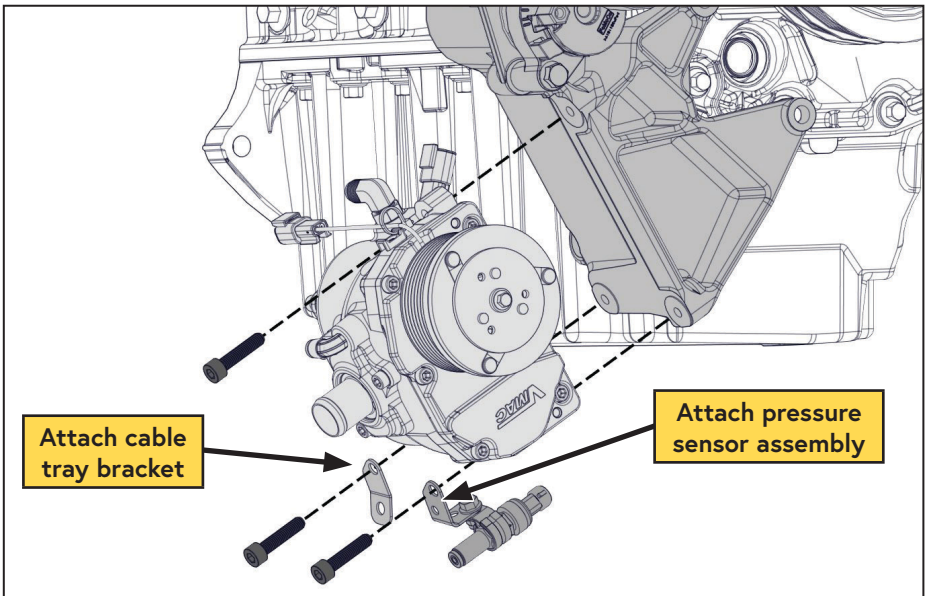

Figure 21 — Mount compressor

- Install and tension the supplied 4 rib VMAC compressor belt, ensuring that it is centered on the compressor clutch (Figure 22).

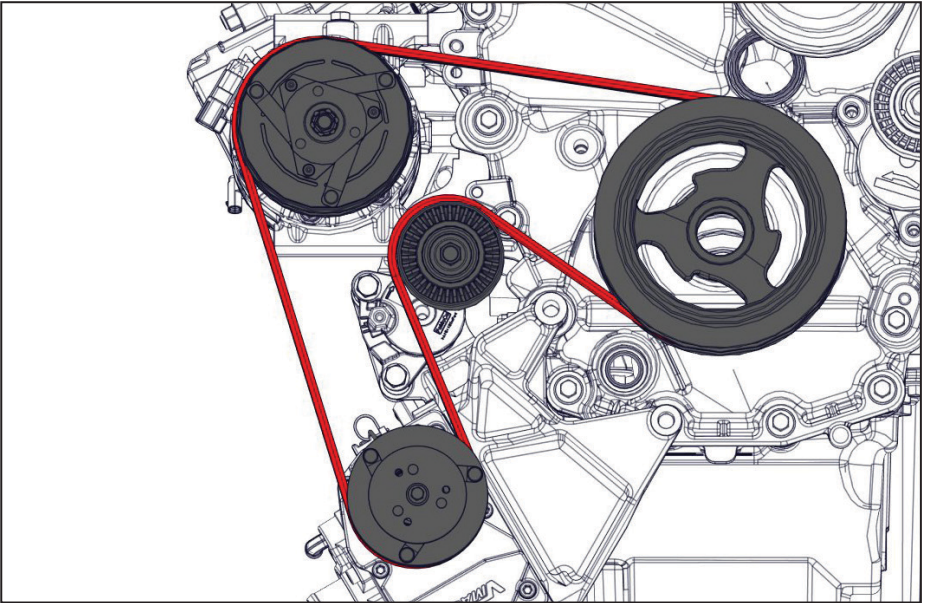

Figure 22 — Route VMAC belt

- Reinstall and tension the OEM 6 rib belt (Figure 23).

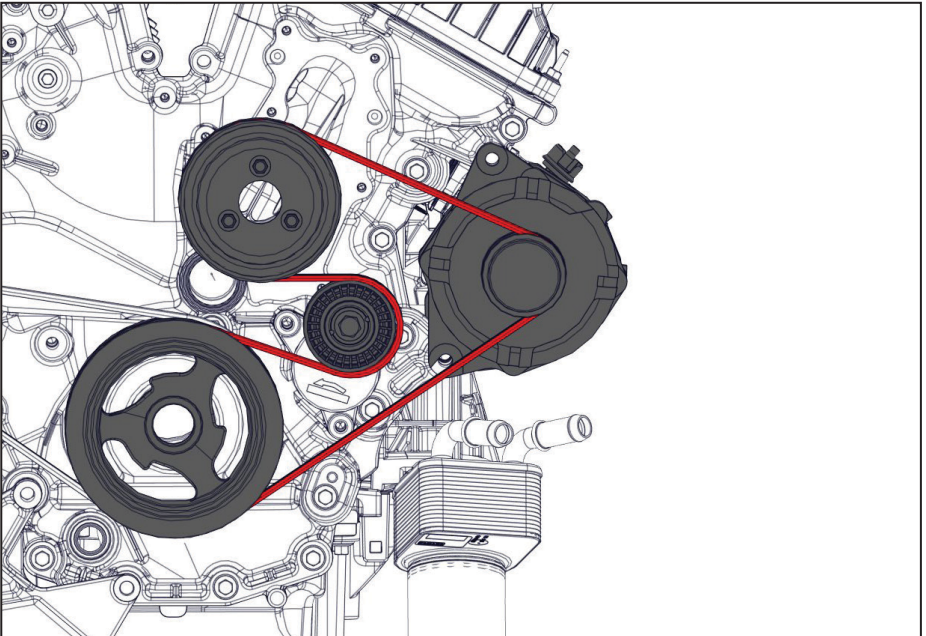

Figure 23 — 6 rib belt routing

Waste Heat Air Separator Package (WHASP) Tank Installation

Tank location guidelines



When determining a mounting location for the WHASP Tank, ensure the following conditions are met:

- Adequate supply of fresh air and venting for the cooling fan.
- Minimum of 12 in of clearance at the front (exhaust side) of the cooling fan.
- Minimum of 6 in clearance at the rear of the unit.
- Hose connections and wiring are accessible.
- Mounted on a level surface.
- Impact protection.
- The oil level sight glass is easily accessible.
- The oil fill, drain port, and filters are accessible for servicing.
- Minimize the hose lengths to maximize performance.

Mounting the WHASP Tank

Refer to (Figure 24 on page 22) for mounting dimensions.

Special consideration must be made to ensure the WHASP Tank will be protected from damage and to ensure that it has adequate ventilation.

In some cases, it may be necessary to fabricate a mounting bracket to position the tank in an appropriate location.

Secure the WHASP Tank by bolting the mounting feet to the installation surface, use M8 or 5/16 in fasteners (not supplied).

Mounting in an Enclosure or Body

Mounting the WHASP Tank in an enclosure will limit access to cooling air or restrict the escape of hot air from around the unit and will have an adverse effect on cooling.

Ensure adequate ventilation is provided for the cooling system to function properly. It is not possible to make absolute recommendations regarding ventilation because of the widely differing configurations that are possible. Duty cycle, ambient temperature and enclosure shape are some of the important variables that need to be taken into account when determining the suitability of enclosure mounting.

Cool air ducted to the cooler and installing an exhaust fan to remove hot air is recommended.



Confirm the hose lengths included in this kit when determining the location of the WHASP Tank and bulkhead fittings. Hose lengths can be found on page 27 or in the IPL. If the WHASP Tank or bulkhead fitting location requires longer hoses, contact a local VMAC dealer. See page 6 for ordering information.

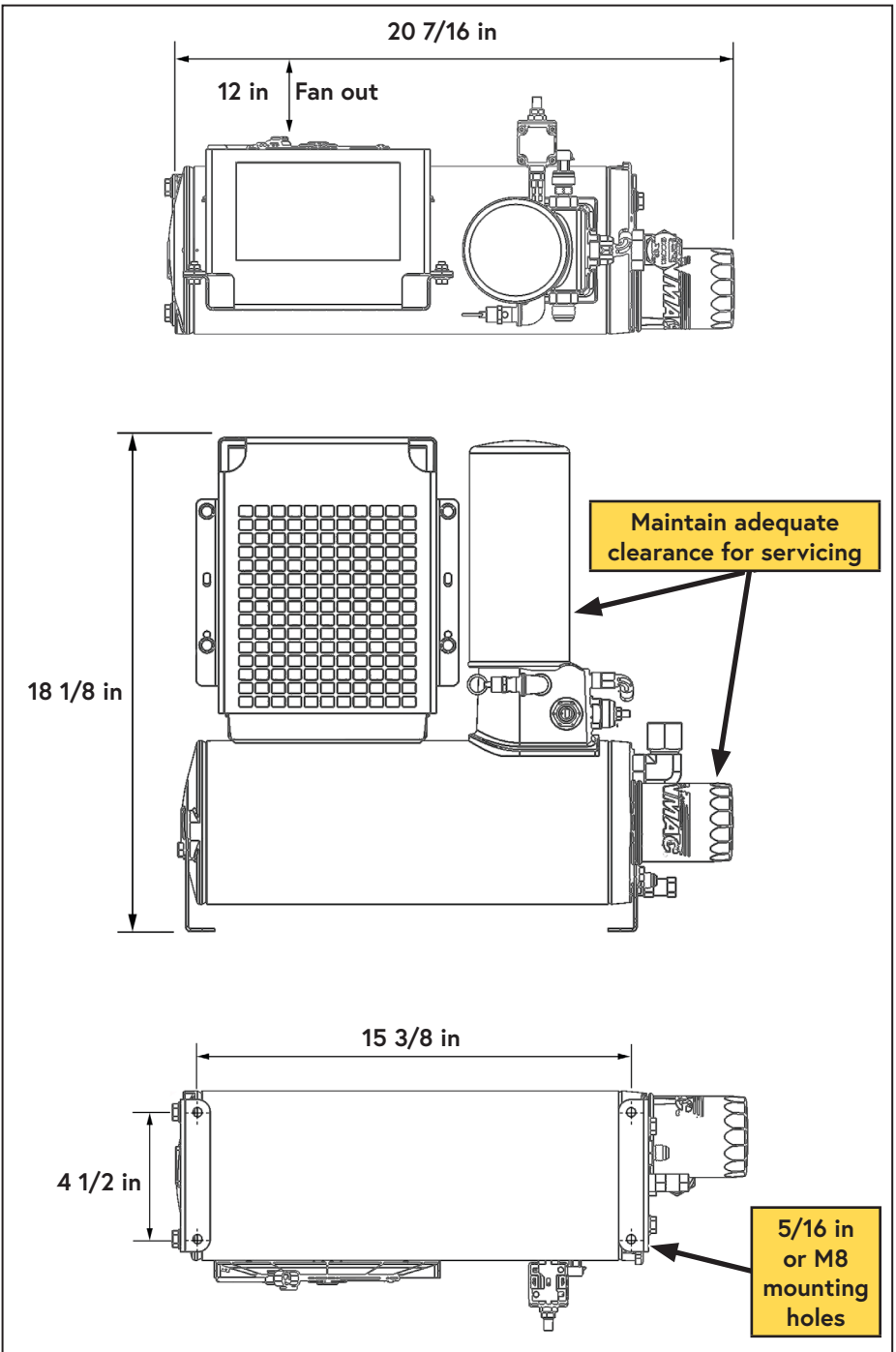

Figure 24 — Minimum WHASP Tank mounting clearances

Mounting the WHASP Tank



If mounting the WHASP Tank above the vehicle's floor, installation of the oil return check valve (P/N: A700308) is required.



Provide ample space to check the oil level, as well as access to the filters and compressor oil drain to facilitate servicing.

The WHASP Tank uses a "puller" fan to cool the air/oil mixture. Position the WHASP Tank to ensure there is adequate air flow and so that the fan is blowing out toward the cargo door. During operation, the door should be kept open to ensure there is a constant supply of cool air to prevent the system from overheating (Figure 25).

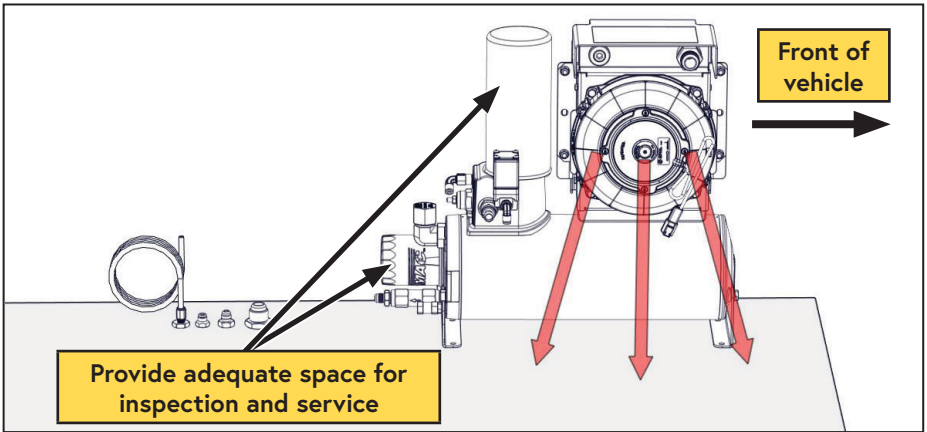

Figure 25 — WHASP ventilation



A minimum of 6 in of clearance is recommended around the radiator (intake) side of the WHASP Tank to allow fresh, cool air to circulate into the cooler and fan (Figure 26).

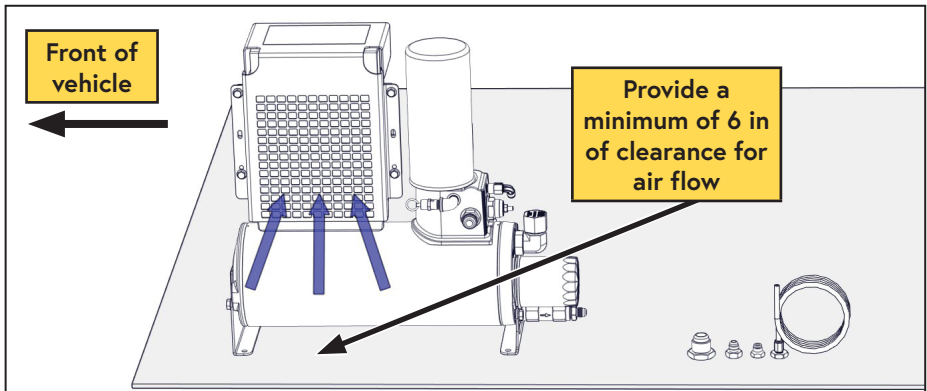

Figure 26 — WHASP ventilation

Bulkhead Fittings Installation



Good judgement must be used during installation. Prior to drilling any holes in the vehicle, confirm the installation location of the WHASP Tank and the bulkhead fittings. Confirm that the supplied hoses will reach from the compressor to the bulkhead fittings, and from the bulkhead fittings to the WHASP Tank. Also ensure that there are no wires, hoses, or other components on the other side of the panel that may be damaged when drilling holes.

(x4) bulkhead fittings are supplied with the system (Figure 27):

- 3 bulkhead fittings are used to pass the system discharge, oil, and scavenge hoses/tubes into the body of the vehicle.
- 1 bulkhead fitting is used to relocate the blowdown muffler outside of the vehicle.

This kit includes hoses of a fixed length to run from the compressor to the bulkhead fittings, and from the fittings to the WHASP Tank.

To maximize compressor performance, hose lengths should be kept as short as possible; if longer hoses are required please follow the hose requirements listed on page 27 of this manual.

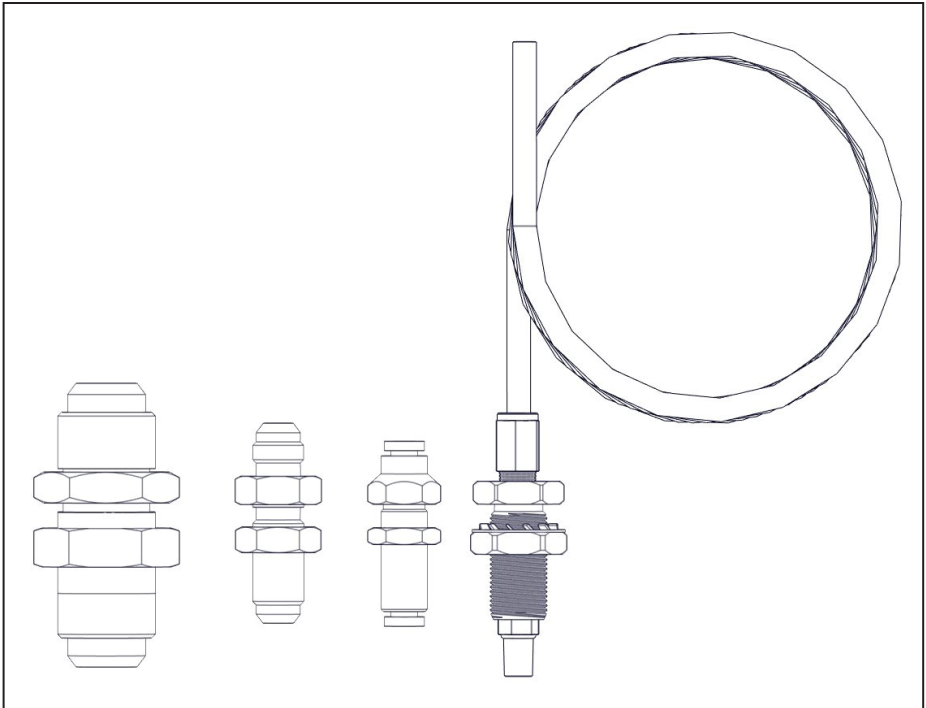

Figure 27 — Bulkhead fittings
(A700224 Remote Muffler accessory shown)



If installing the bulkhead fittings in an alternate location, ensure the remote blowdown muffler is located where road debris (e.g. mud, ice, etc.) will not accumulate and prevent proper blowdown.



This kit includes hoses of an adequate length to connect to the location specified in this manual.

If installing in an alternate location:

- *Contact a VMAC dealer to order hose extensions.*

Or

- *If sourcing custom length hoses locally, Refer to this Knowledge Base article for compatible hoses: [EXT-ALL-010-Required-VMAC-Hoses.pdf](#).*
- *As individual installation locations may vary, ensure the bulkhead fittings are centered on the top of the structural ribs (where applicable).*

Drill the bulkhead fitting holes using a drill, step drill or hole saw. Leave enough room between the fittings to allow access for a wrench (Figure 28, Figure 29, Figure 30):

- Discharge from the compressor: $\varnothing 1\ 1/8$ in.
- Oil return: $\varnothing 9/16$ in.
- Oil scavenge: $\varnothing 5/8$ in.
- Remote blowdown: $\varnothing 5/8$ in.

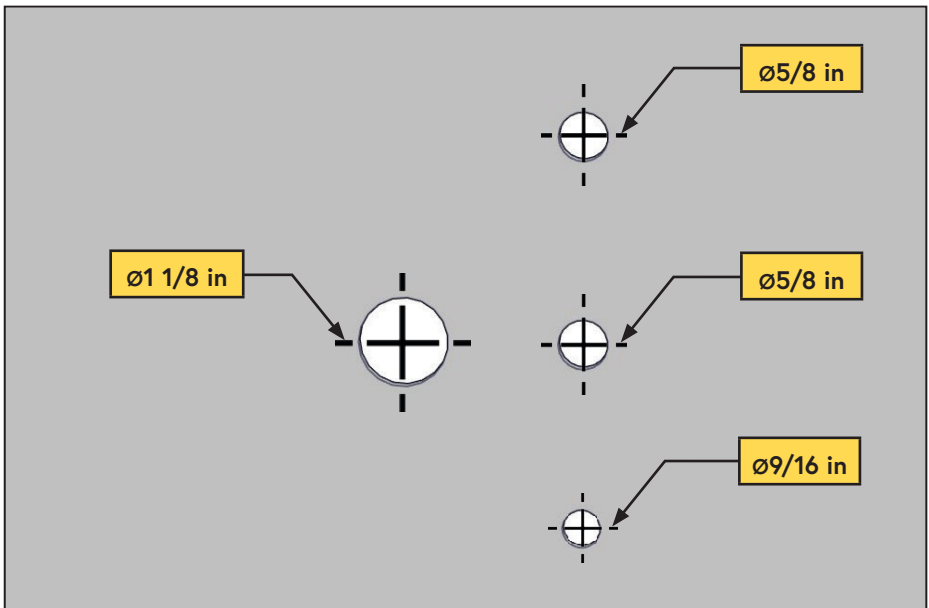

Figure 28 — Hole diameter

- Fit the bulkhead fittings through the top of the hole and secure from the bottom with the supplied nuts. Apply Loctite 567 (thread sealant) when installing the 1/4 in push-to-connect fittings in the bulkhead fittings (Figure 29, Figure 30).

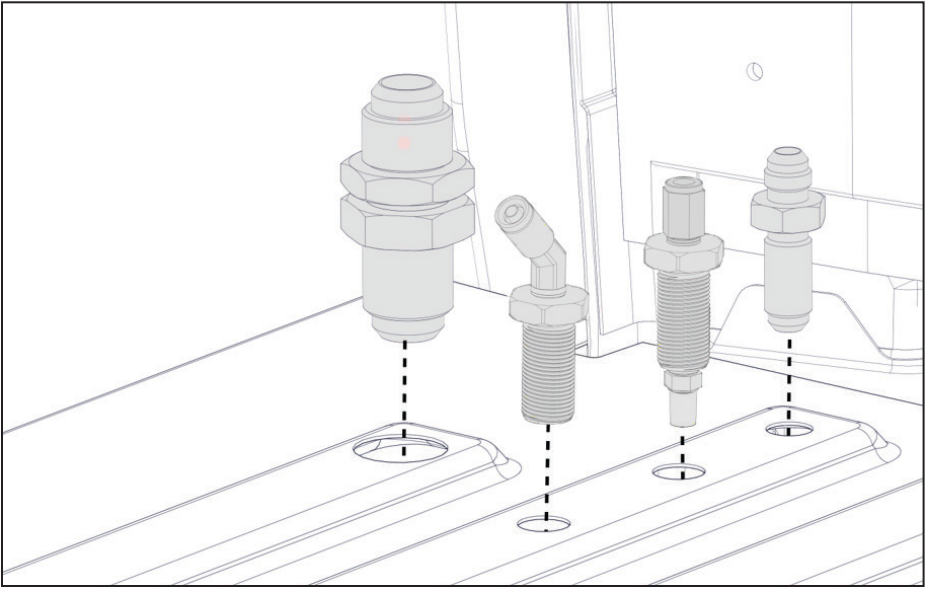

Figure 29 — Interior View

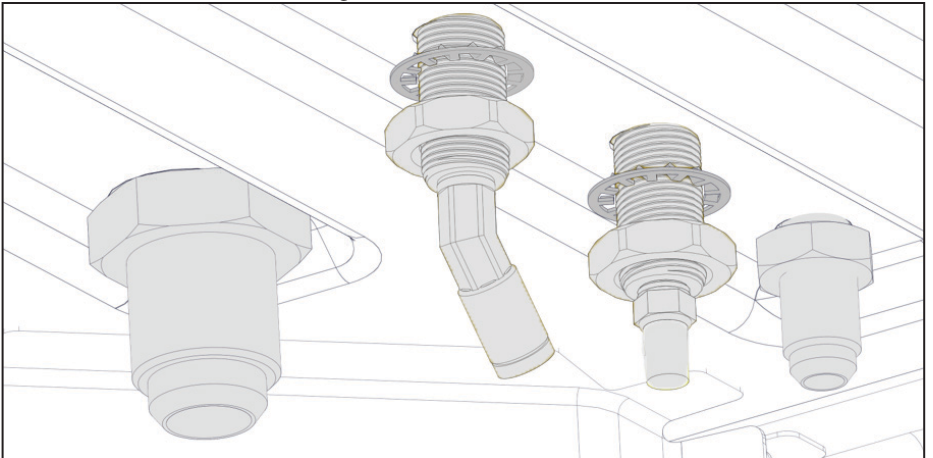

Figure 30 — Exterior View

Hose Requirements



*Only attempt to shorten the supplied hose if there is access to the appropriate equipment. **Do not** attempt to cut the hose and splice it using hose clamps.*



VMAC Compressor oil will degrade rubber lined hoses, use only hoses with an AQP elastomer type liner. Refer to this Knowledge Base article for compatible hoses: [EXT-ALL-010-Required-VMAC-Hoses.pdf](#)

The 1/4 in PTFE tube, and the 3/8 in and 3/4 in hoses with AQP elastomer liner are specifically designed to work with VMAC compressor oil and at compressor operating temperatures.

Based on the desired location of the WHASP Tank, the hose lengths provided with this system may not be ideal. They can be shortened or replaced as necessary, or hose extenders can be used.

VMAC recommends shortening these hoses as a preferred alternative to coiling up and securing the excess. **Shorter hose length will maximize system performance.**



Avoid using 90° fittings wherever possible as they cause flow restrictions and negatively impact performance.

The following hoses are included with this compressor kit:

From the compressor to the bulkhead fittings:

- 3/4 in × 120 in.
- 3/8 in × 120 in.
- 1/4 in (PTFE Tube) × 125 in.

From the WHASP Tank to the bulkhead fittings:

- 3/4 in × 96 in.
- 3/8 in × 84 in.
- 1/4 in (PTFE Tube) × 108 in.

If longer hoses are required:

To order parts, contact a VMAC dealer. The dealer will ask for the VMAC serial number, part number, description and quantity. See page 6 for ordering information.

- Refer to this article for a list of compatible hoses: [EXT-ALL-010-Required-VMAC-Hoses.pdf](#)
- OTC fittings are required for the VMAC supplied hose.
- Push-lock fittings are suitable if FC332 hose is used.
- If Push-lock fittings are being used, do not use hose clamps as they will damage the hose and cause leaks.

Hose Installation



When routing hoses, ensure cap plugs are installed so that contaminants do not get in the line. Take care when routing hoses, as a hose failure may damage the compressor and/or cause injury.



All hoses, tubes and wires that are installed, rerouted or shifted during the installation must be secured so that they do not contact any hot, sharp or moving parts. Use rubber coated P-clips wherever possible. Follow the routing suggestions in this manual and cover all hoses with plastic loom.



*Use of an air receiver tank (minimum 6 USG) is required with this application.
Follow the instructions on page 58 of this manual to prevent damage to the system.*

PTFE Tubing, Loom, and Push-To-Connect Fittings

- PTFE tubing should only be cut using proper tubing cutters. Side cutters, utility knives, etc. will deform the tube, preventing a proper seal (or leave sharp edges which cut the internal O-ring).
- When applying loom to the PTFE tube, leave approximately 1 in between the loom and the fitting.
- Ensure the tube is clean, cut at 90° and that there are not sharp edges.
- Lubricate the tube and, with the collet pushed into the fitting, firmly push the tube into the fitting until the tube is fully seated.
- Slide the collet out, away from the body of the fitting to lock the tubing in place.
- Ensure the tube does not have any "play" to prevent the O-ring from wearing.

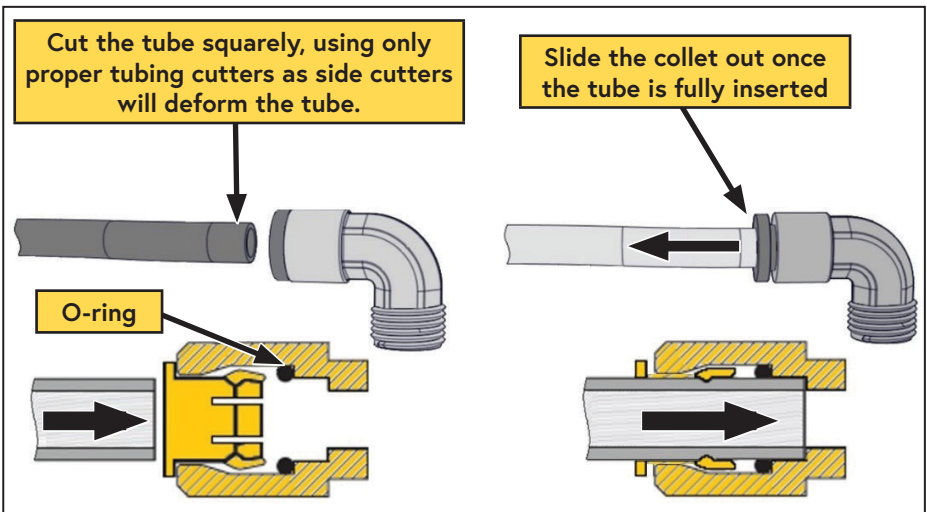

Figure 31 — Push-to-connect fittings

Hose/tube connections



Ensure there is sufficient slack in the hose routing to allow for normal engine/body movement.

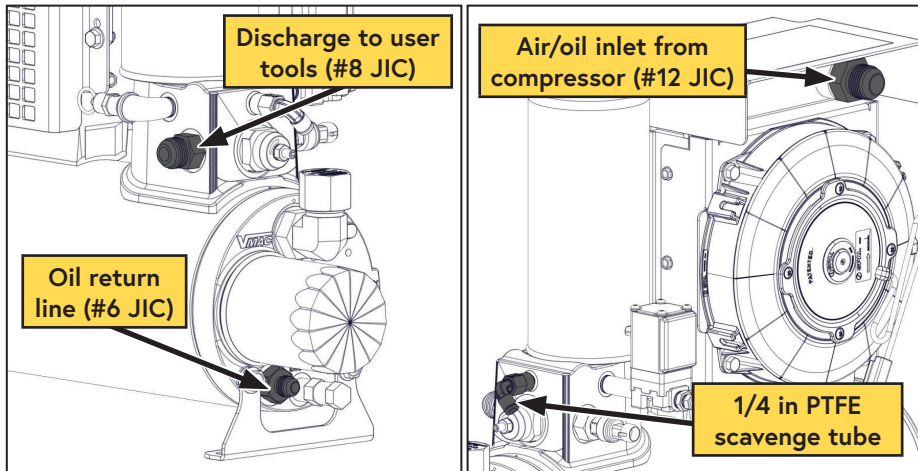

Figure 32 — WHASP Tank connections

Remote Blowdown Muffler Installation

The WHASP Tank automatically depressurizes when the clutch disengages. This prevents damage to the compressor when the clutch engages.

Installing the blowdown muffler outside of the vehicle (enclosed installation applications) will reduce cabin noise during blowdown, and will ensure any oil vapour will be safely discharged outside of the vehicle.

- Apply Loctite 567 (thread sealing) compound to the supplied fitting and install it into the blowdown solenoid (Figure 33).

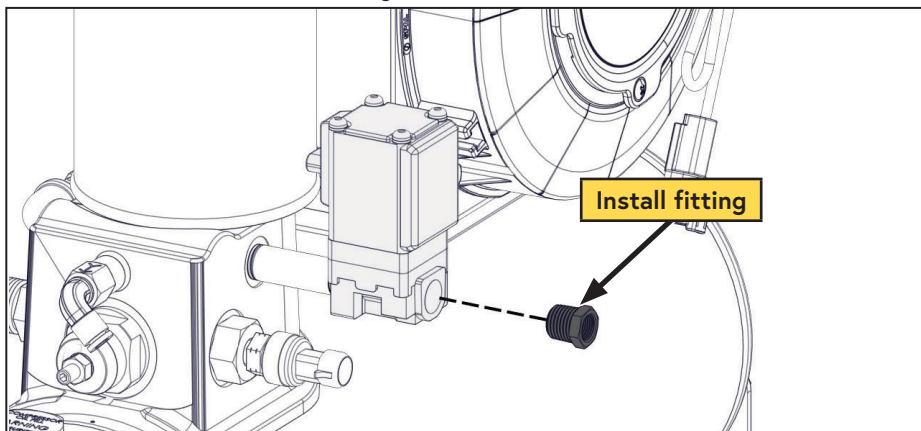

Figure 33 — Install fitting

- Separate the PTFE tube from the fittings.
- Apply Loctite 567 (thread sealing) compound to the 1/4 in push-to-connect fitting and install it into the fitting on the blowdown solenoid (Figure 34).

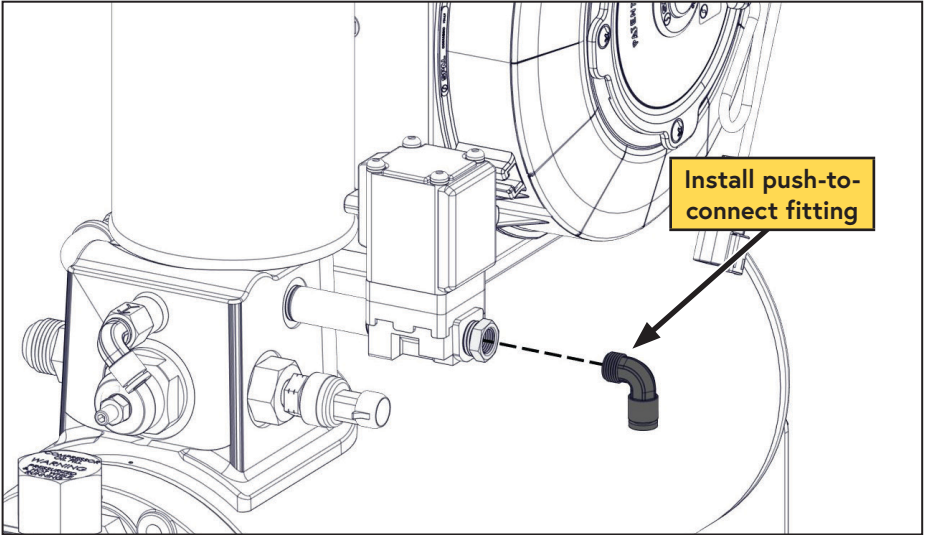

Figure 34 — Install push-to-connect fitting

- Apply the supplied 1/4 in split loom to the 1/4 in PTFE tube.
- Connect the 1/4 in PTFE tube into the push-to-connect fitting installed in the WHASP Tank (Figure 35).

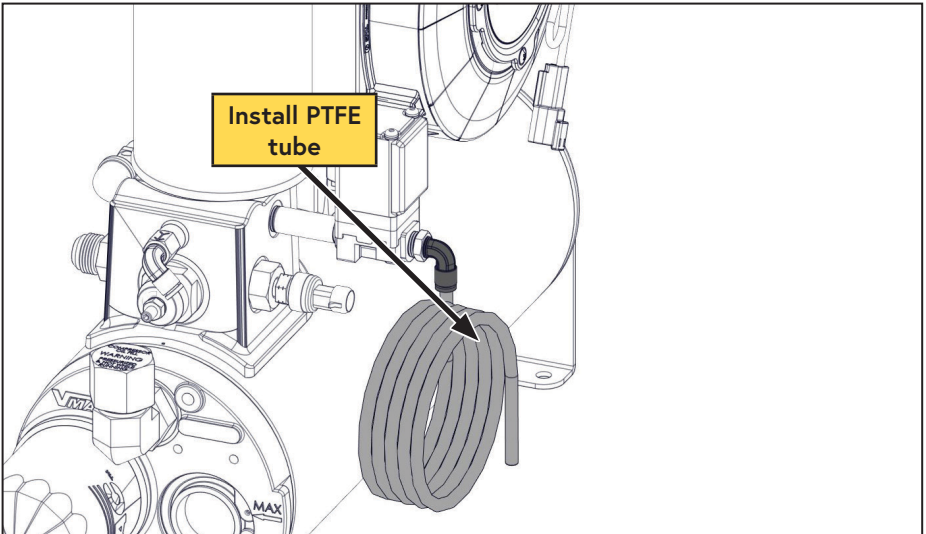

Figure 35 — Tubing Installation

- Route the 1/4 in PTFE tube to the bulkhead fitting, ensuring the tube will not kink or be damaged from incidental damage from other operations.



Ensure the PTFE tube is cut square and that there are no sharp edges. Use only a tube cutter or a new unused utility knife blade. Do not use side cutters as this will deform the tube.

- Cut the PTFE tube to length.
- Install the tube into the push-to-connect bulkhead fitting (Figure 36)

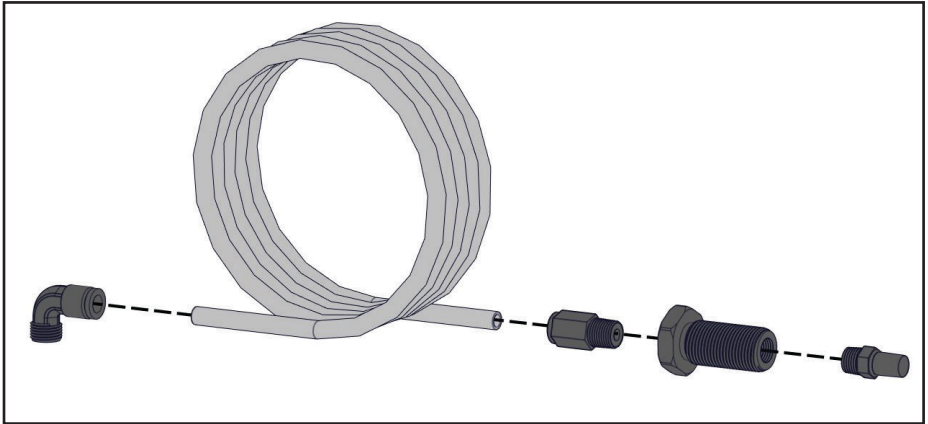

Figure 36 — Tubing Installation Remote Blowdown Muffler assembly

Connecting the Interior Hoses

- Connect the straight ends of the shorter 3/4 in and 3/8 in hoses to the top side of the bulkhead fittings.
- Connect the shorter 1/4 in PTFE tube to the top side of the bulkhead fitting.
- Bundle the PTFE tube and hoses together and route them to the WHASP Tank.
- Connect the 90° fitting on the 3/4 in hose to the #12 JIC fitting (air/oil inlet) on the cooler above the fan.
- Connect the 90° fitting on the 3/8 hose to the #6 JIC fitting (oil return fitting) beneath the oil filter on the tank.
- Connect the 1/4 in PTFE tube to the 1/4 in push-to-connect (oil scavenge) fitting near the coalescing filter.
- Connect the discharge fitting (#8 male JIC) to the customer's air system (hose not supplied).
- Secure all hoses, tubes, and wires with P-clips and/or cable ties.



**Ensure the union Tee is installed within 6 in of the compressor.
Install the pressure sensor within 48 in of the union Tee.**

- From the 24 in spool of 1/4 in PTFE tubing, connect the scavenge tube to the compressor, pressure sensor assembly, and Union Tee (Figure 37).

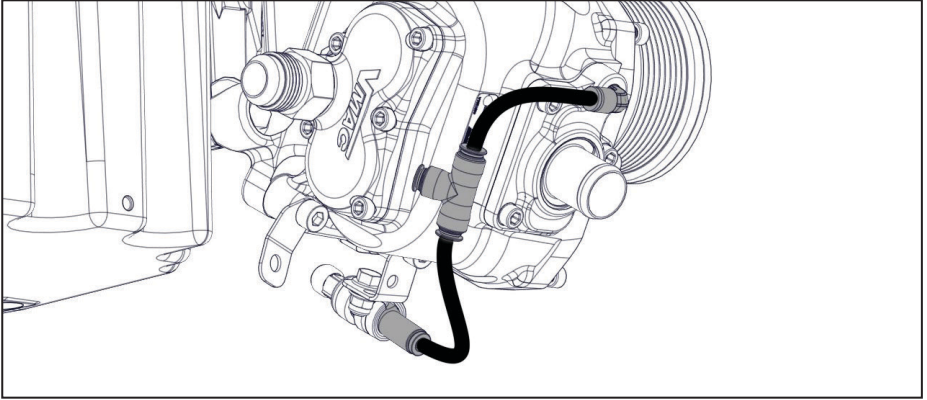

Figure 37 — Connect PTFE tubes

- Connect the 125 in PTFE tube to the Union Tee.
- Connect one end of the 3/4 in hose to the compressor discharge fitting on the rear of the compressor. Direct the hose toward the rear of the vehicle, between the engine and the crossmember (Figure 38).

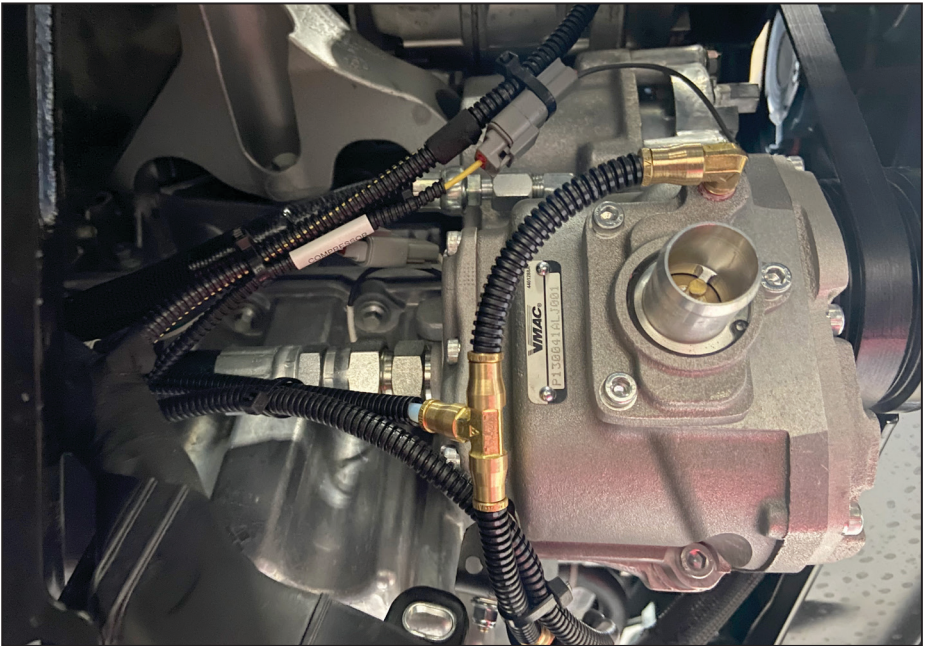

Figure 38 — Install 3/4 in hose

- Apply the supplied split loom to the 1/4 in PTFE tubes.
- Route the 3/8 in and 3/4 in hoses, together with the 1/4 in PTFE tube back along the engine, toward the transmission.
- Route the hose bundle under the rear of the engine towards the driver side of the vehicle (Figure 39).

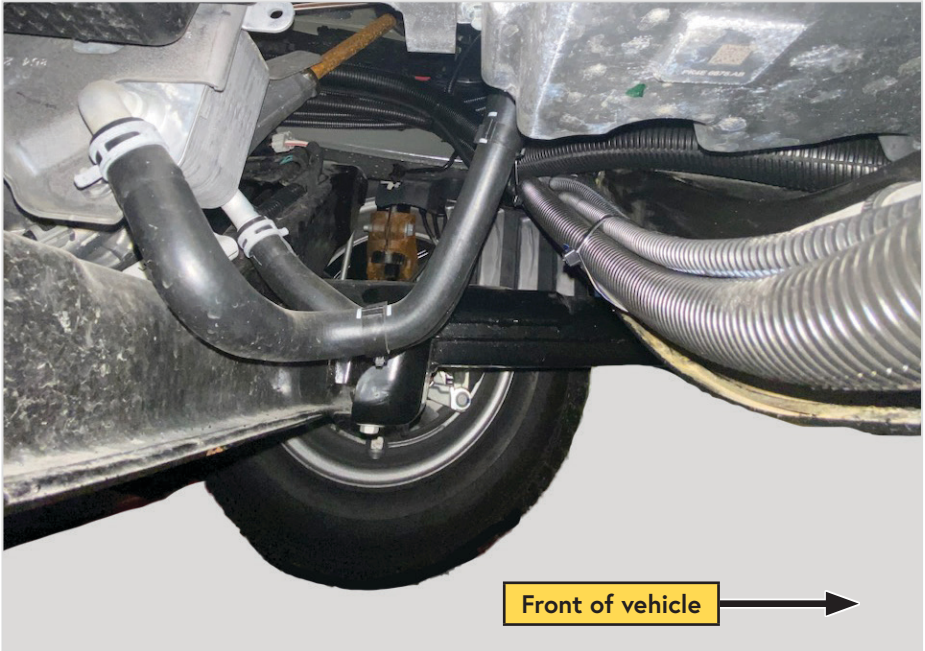

Figure 39 — Route hoses under the oil pan

- Route the hoses along the inside of the driver side frame rail and secure them using the 2 supplied P-clips and 5/16 in x 3/4 in sheet metal screws in the existing holes on the frame (Figure 40).

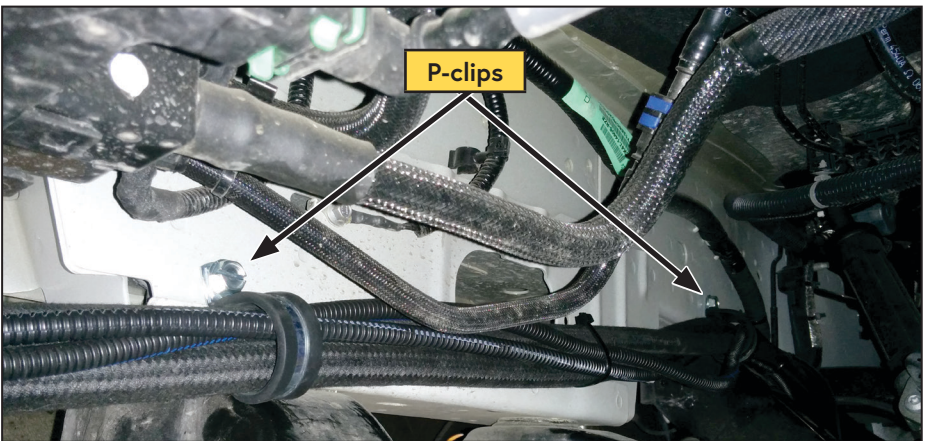

Figure 40 — Hose routing along inside of driver side frame

- Route the hoses above the fuel filler hose and toward the rear of the fuel filler housing (Figure 41, Figure 42).

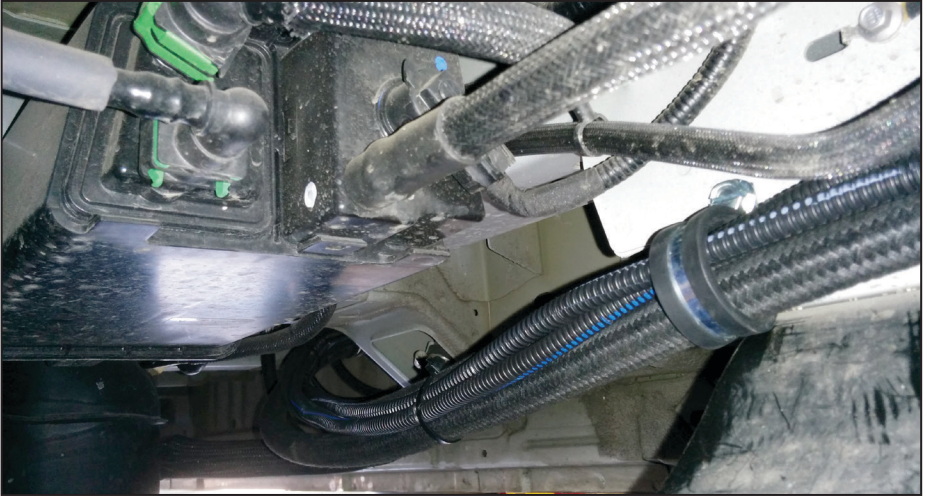

Figure 41 — Hose routing continued

- Secure the hose using the supplied P-clip and 5/16 in x 3/4 in sheet metal screw, in the location shown (Figure 42).

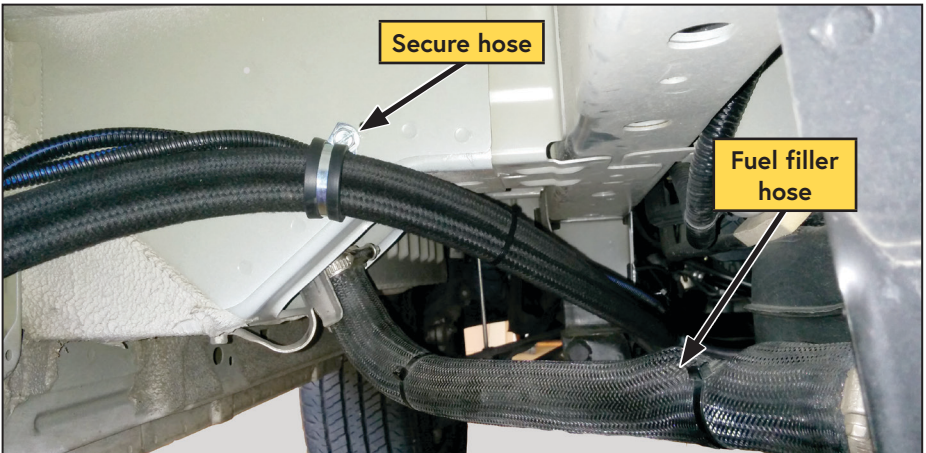

Figure 42 — Hose routing above fuel filler hose

- Attach the 3/4 in x 120 in, 3/8 in x 120 in hoses and the 1/4 in x 125 in PTFE tube to the underside of the bulkhead fittings. Ensure all of the fittings are fully seated, tight and secure.
- Ensure all of the hoses are routed away from any hot, sharp or moving parts, hydraulic lines, and vehicle wiring. Use cable ties, rubber coated P-clips, and suitable hose protection as required. If the vehicle is 4WD, ensure the hoses are protected from the front driveshaft.

Adding Oil to the System



The VMAC supplied and approved compressor oil must be used in this system. Failure to use this special oil will result in damage to the compressor and will void warranty.

Do not overfill the system. Overfilling the system with oil can flood the sight glass window and make the system appear empty.

- Remove the fill cap on the WHASP Tank (above the sight glass) (Figure 43).
- Using a funnel, pour oil into the tank until the oil level in the sight glass reaches the "MAX" line. **The system capacity is 4 L.**
- Reinstall the fill cap and tighten it securely. Ensure the fill port remains accessible as it will be necessary to check and top up the oil after the first compressor start.

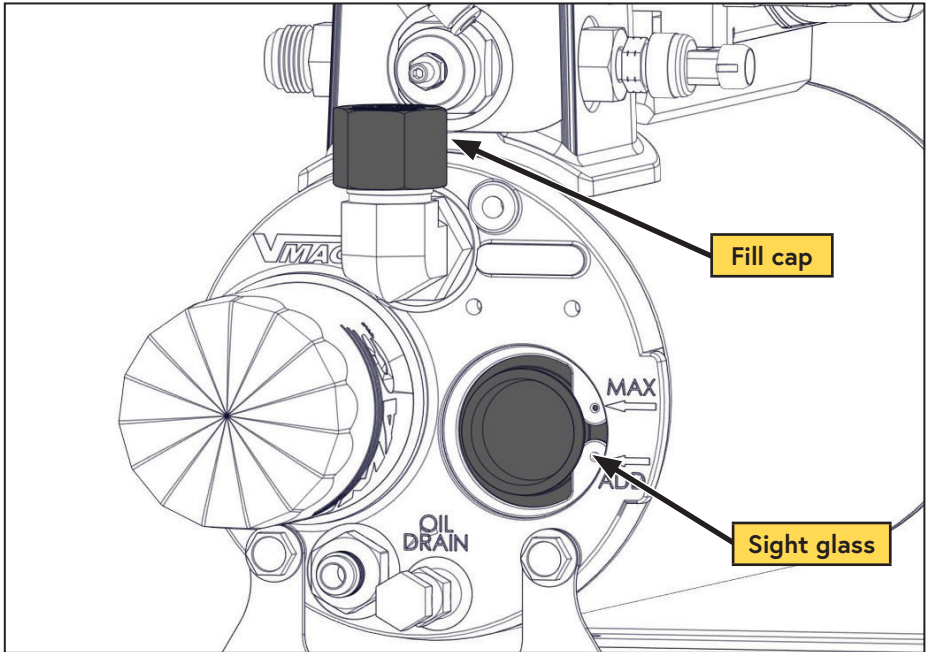

Figure 43 — Filling the WHASP Tank

Electrical Schematic

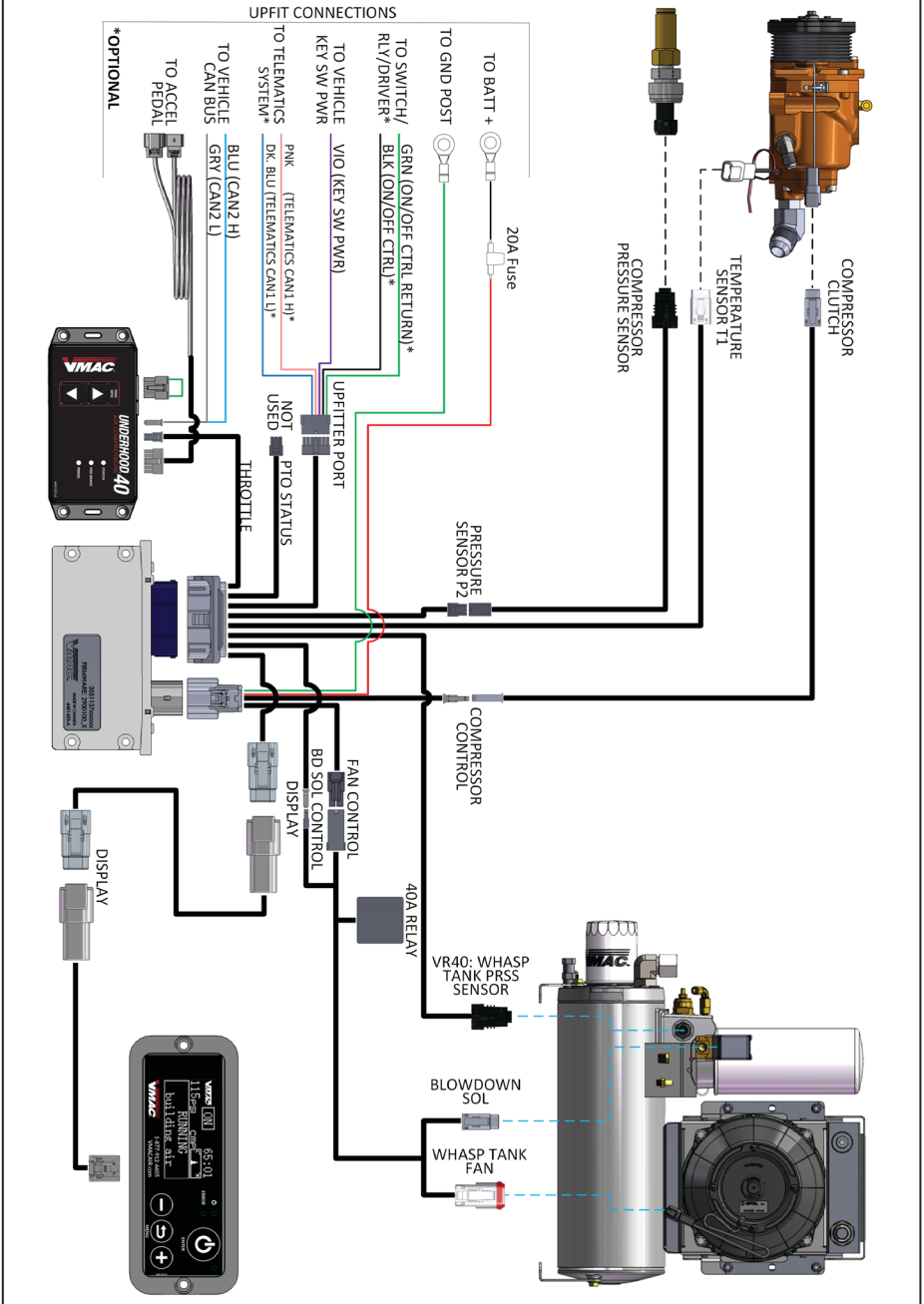

Figure 44 — Electrical schematic

Harness Reference



All references to "12 V" refer to the voltage supplied by the vehicle battery. This voltage can range from 9 V to 14.4 V dependent upon battery health, the alternator, and whether the engine is running.

Upfitter Port (16-pin black microfit connector)

Colour	Pin	Function	Notes
Green	3	ON/OFF CTRL return (GND)	<i>Optional:</i> Connect a momentary switch between these wires. See "Remote Start Integration (Optional)" on page 52.
Black	10	ON/OFF CTRL signal input	
Violet	13	KEY SW PWR signal input	Connect to vehicle 12 V key switched power.
Pink	9	TELEMATICS + (CAN H)	J1939 compatible telematics interface. See VMAC for PGN documentation.
D. Blue	2	TELEMATICS – (CAN L)	

Fan Relay (40A 12V relay)

Colour	Pin	Function	Notes
Red	86	Relay coil +	12V constant.
Red	30	12 V power	—
Brown	85	Relay coil -	Switched GND from Controller. 0 Ω to GND when fan is ON, High Ω when OFF.
Yellow	87	12 V power output from relay (Activate Fan)	Switched power from relay. 12 V when fan is ON, 0 V otherwise.

Chassis GND (Ring terminal)

Colour	Pin	Function	Notes
Green	—	VMAC System ground	Connect to dedicated chassis ground point or battery "-" terminal.

Batt "+" (Ring terminal)

Colour	Pin	Function	Notes
Red	—	VMAC System 12 V power	Connect to battery "+" terminal. Power supply for VMAC system. Protected with 20 A inline fuse.

Display (4-pin grey Deutsch DTM connector)			
Colour	Pin	Function	Notes
Green	1	Ground	System power.
Red	2	12 V	
Pink	3	TELEMATICS + (CAN H)	VMAC internal CAN bus. This bus is internally connected to TELEMATICS +/- in the Upfitter Port.
D. Blue	4	TELEMATICS – (CAN L)	

Display (4-pin black connector)			
Colour	Pin	Function	Notes
Green	3	Ground	System power.
Red	4	12 V	
Pink	1	TELEMATICS + (CAN H)	VMAC internal CAN bus. This bus is internally connected to TELEMATICS +/- in the Upfitter Port.
D. Blue	2	TELEMATICS – (CAN L)	

Pressure Sensor P2 (3-pin black microfit connector)			
Colour	Pin	Function	Notes
Green	1	Ground	—
Red	2	5 V power	—
White	3	Sensor signal input	Linear 0.5 V (0 psi) to 4.5 V (200 psi) signal.

Compressor Pressure Sensor (3-pin black MP150 connector)			
Colour	Pin	Function	Notes
Green	A	Ground	—
Red	B	5 V power	—
White	C	Sensor signal input	Linear 0.5 V (0 psi) to 4.5V (200 psi) signal.

Compressor Control (2-pin minifit connector)			
Colour	Pin	Function	Notes
Green	1	Ground	—
Yellow	2	12 V power output from Controller (Activate Compressor)	Switched power from Controller. 12 V when compressor clutch is engaged, 0 V otherwise.

Throttle (DTC) (12-pin black microfit connector)			
Accelerator pedal connection.			

Throttle (DTC) (4-pin black microfit connector)			
Colour	Pin	Function	Notes
Yellow	3	12V power output from Controller (activate throttle (DTC))	Switched power from Controller. 12 V when system is ON (to monitor interlocks), 0 V otherwise.
Pink	4	TELEMATICS + (CAN H)	VMAC internal CAN bus. This bus is internally connected to TELEMATICS +/- in the Upfitter Port.
D. Blue	2	TELEMATICS – (CAN L)	

Throttle (DTC) (8-pin white minifit connector)			
Colour	Pin	Function	Notes
Green	1	—	Jumper wire.
	8		
Black	2	Manual park brake	*Select applications only.

Temperature Sensor T1 (3-pin grey Deutsch DTM connector)			
Colour	Pin	Function	Notes
Green	1	Sensor return (GND)	Non-linear type K thermistor.
White	3	Sensor signal input	

WHASP Tank Fan (2-pin grey Deutsch DT connector)			
Colour	Pin	Function	Notes
Yellow	1	12 V power output from relay (activate fan)	Switched power from relay. 12 V when fan is ON, 0 V otherwise.
Green	2	Ground	—

WHASP Tank Pressure Sensor (3-pin black MP150 connector)			
Colour	Pin	Function	Notes
Green	A	Ground	—
Red	B	5 V power	—
White	C	Sensor signal input	Linear 0.5 V (0 psi) to 4.5 V (200 psi) signal.

Blowdown Sol (2-pin grey Deutsch DTM connector)			
Colour	Pin	Function	Notes
Green	1	Ground	—
Yellow	2	12 V power output from Controller (activate blowdown solenoid).	12 V when blowdown solenoid is engaged, 0 V otherwise.

Electronics and Control Component Installation

Best Practices

- Ensure the system ground is connected to the VMAC recommended ground locations whenever possible. These locations are designed to be used as a ground point and can handle high currents while providing a low resistance connection. Do not use any bolt as a ground location as the increased resistance could cause system brown-out when the high current fan kicks on.
- Route all wires to ensure they will not contact hot, sharp or moving parts (including the park brake mechanism, steering column, and pedals).
- Before drilling any holes ensure there are no OEM wires, hoses, or components that may be damaged.
- Do not use a test light to probe for power on vehicle circuits, the increased current draw of the test light may damage components.
- VMAC recommends using only sealed crimp connectors for all electrical connections (unless otherwise specified).
- To ensure a durable connection, use only good quality crimping tools.
- Harness protection. High temperature loom is used on all supplied harnesses. If loom is to be added to harnesses:
 - Use high temperature loom where high temperatures may be expected.
 - Use spiral loom in areas with high vibration.

Inline Butt Splice Connections

- Cut the wire approximately 2 in from the connector.
- Strip approximately 3/8 in from the end of both sides of the cut wire, as well as from the end of the wire being spliced inline.
- Twist the wire to be spliced inline, together with the "live" side of the wire (not the wire attached to the connector).
- Slide the butt connector onto the twisted wires and crimp it.
- Insert the "connector side" of the wire into the butt connector and crimp it.
- Lightly tug the wires to ensure they are properly crimped.
- Using a heat gun, carefully apply heat to the butt connectors to seal the connection.

OEM Wire Colours

The OEM wire colours referenced in this manual are correct at the time of writing. OEMs may make running changes to the wire colours on their production line as needed, and without notice.

In the case of a wire colour discrepancy, the described location (e.g. pin number in a specific connector) will be considered to be definitive. If there are any questions or concerns, please contact VMAC Technical Support.

Posi-Tap Connectors

- Slide the OEM (live) wire into the slot on the large cap as far as it will go.
Note: It is imperative that the OEM wire is straight. Make this connection first.
- Thread the tap (barrel with pin) over the slotted cap, ensuring the pin is centered on the wire.
- Tighten the tap firmly but do not over tighten it as over tightening will cause the wire to twist.
- Unscrew the small cap but leave the last few threads engaged.
- Strip approximately 3/8 in from the end of wire.
- Twist the wires to be Teed in together and insert the wire into the cap. Some resistance will be felt until the wire bottoms out.
- Firmly tighten the cap.
- Ensure all of the connections are firmly tightened by hand (overtightening will cause the threads to strip).
- Confirm the connection by giving a light tug to the Teed in wire (5 lb – 10 lb) to ensure it does not release from the connection.

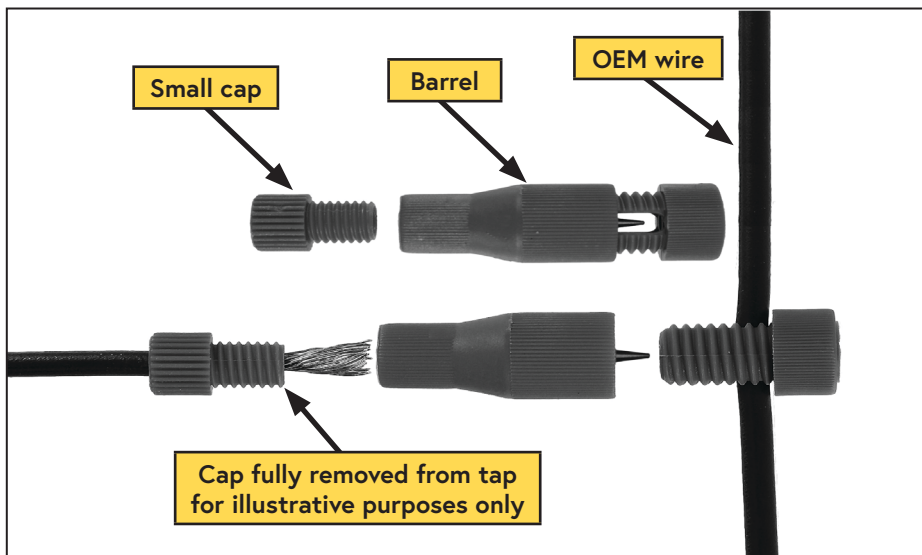

Figure 45 — Posi-Tap wire connector

Upfitter Electrical Requirements



The VMAC power harness includes a 14 ft (4.25 m) power wire and a 6 ft (1.8 m) ground wire. VMAC does not recommend modifying the length of this harness. Coil any excess harness and secure it safely out of the way.

If lengths greater than this are required, consult VMAC Technical Support prior to installation.

VMAC's UNDERHOOD 40 Air Compressor systems require up to 20 A at 12 V dc (nominal) to operate. A 20 A inline fuse is included on the red power supply line.

Power Connection

Power should be supplied directly from the battery. If this is not possible, the main power must be supplied from a source that is capable of 20 A constant.

Ground Connection

To ensure an uninterrupted supply of power to the VMAC system, the ground wire should be routed to either a dedicated vehicle chassis ground post, or to the negative terminal of the battery (preference given to the dedicated chassis ground post).

Confirm the desired ground location is acceptable by using an ohm meter to measure the resistance between the ground point and the negative battery terminal. Resistance should be less than 1 Ω .

The violet wire on the Upfitter Interface harness (labeled "KEY SW PWR") requires connection to a key switched 12 V source. The default location is indicated later in this manual.

Controller, DTC and Display Box Installation

Display Box

The display can be mounted in any covered area. The display is not waterproof and should not be directly exposed to the weather.

- If mounting in the cab, omit the 10-foot display extension and mount where convenient.
- If mounting near the back of the vehicle, attach the 10-foot display extension and run the display harness to the rear of the vehicle.

Controller

Mount on the driver side, up under the dashboard or under the driver seat.

Ensure the Controller is out of the way of pedals, steering column, and park brake mechanism, or under the driver seat.

DTC

Ensure the DTC is mounted within reach of the supplied pedal harness, normally the DTC is mounted near the accelerator pedal)



When determining harness routing, consider the relative motion of the engine, cab, and the chassis. Ensure the harnesses are adequately protected from abrasion, and are secured away from any hot, sharp or moving parts.

In Cab Wiring

- Mount the display box in a convenient location (such as the center console or bulkhead) (Figure 46).

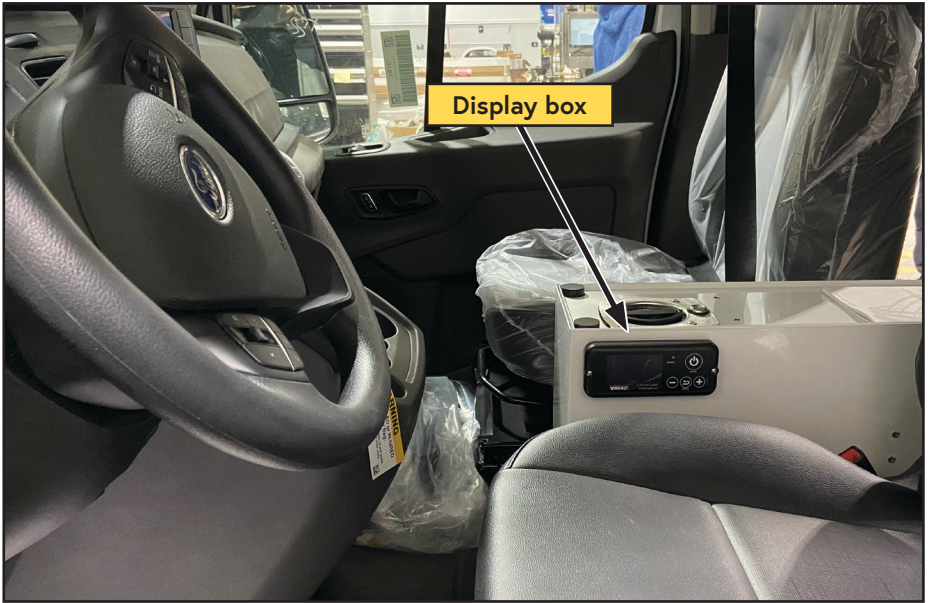

Figure 46 — Install display box

- Remove the battery and battery box (Figure 47).

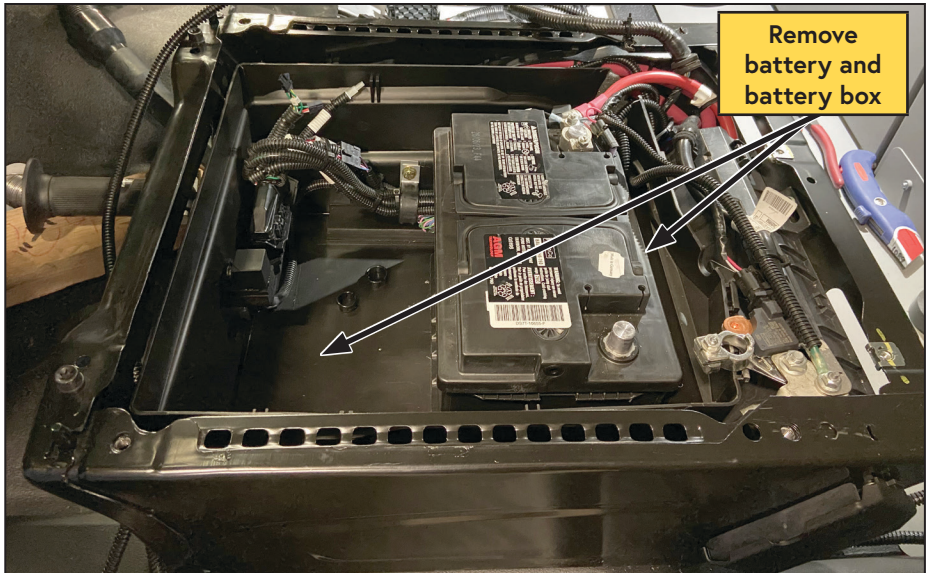

Figure 47 — Remove battery box

- Remove the lower dashboard panel (below the steering wheel).
- Remove the light switch panel to the left of the steering wheel (disconnect the (x2) harnesses).
- Remove the plastic subframe (Figure 48).

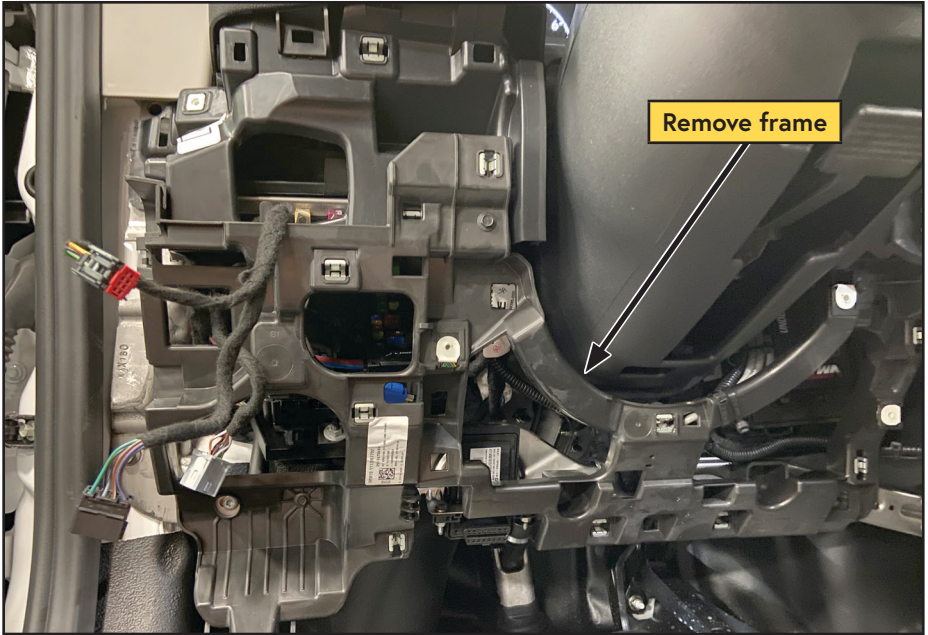

Figure 48 — Remove lower dashboard / sub frame

- Remove the cover from the fuse box (Figure 49).



Figure 49 — Mount DTC

- Using the DTC as a template, drill (×4) holes in the fuse box cover.
- Using cable ties, mount the DTC to the fuse box cover (Figure 50).



Figure 50 — Mount DTC

- Electronic Park Brake, skip to "Electronic (push button) Park Brake" on page 46.

Manual Park Brake

- Install the 8 pin connector with the black wire, and jumper wire into the DTC.
Discard the other connector as it will not be used with this installation (Figure 51).

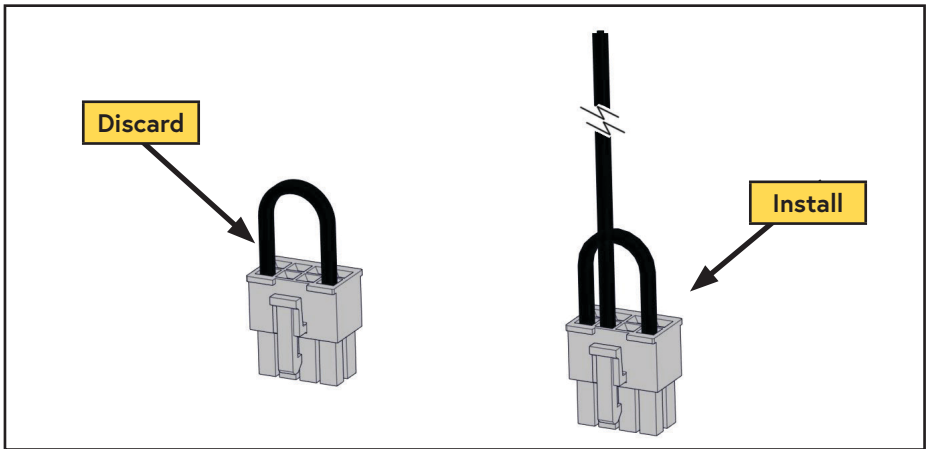

Figure 51 — Manual park brake 8 pin connector

- Splice the black wire, running from the throttle control, to the white wire with violet stripe located at either:*
 - *Manual Park Brake: The park brake switch.
 - *The 6 pin connector (proximate to the 10 pin connector located below).

Electronic (push button) Park Brake

- Install the 8 pin connector with the jumper wire into the DTC. Discard the other connector as it will not be used (Figure 52).

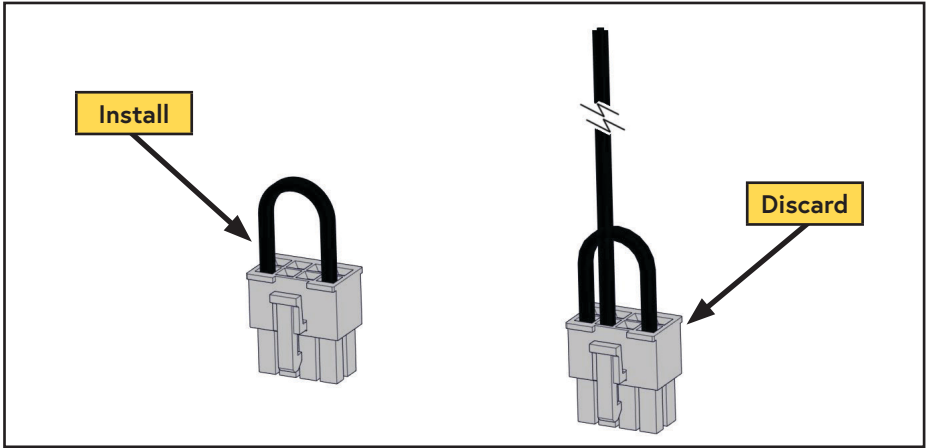

Figure 52 — Electronic park brake 8 pin connector

All Systems

- Reinstall the fuse box cover.



Do not modify the throttle pedal harnesses!

Unauthorized modification of the pedal harness could result in injury or death.

- Unplug the OEM cable from the accelerator pedal and plug it into the matching connector from the DTC.
- Plug the cable from the DTC into the matching connector on the accelerator pedal.
- Connect the green 14 AWG wire to either:*
 - *Battery ground post.
 - *Either of the OEM ground bolts located on the floor between the seats.
- Bundle the following wires together.*
 - *Red 14 AWG wire.
 - *Violet 20 AWG wire "KEY SW PWR".
- Route this bundle along the OEM harness branch to the underside of the driver seat where the battery connections are located.
- Connect the ring terminal on the red wire to the positive battery terminal.

- Splice the supplied section of wire (with crimped terminal) onto the violet wire ("KEY SW PWR") and insert the terminal into pin 6 of the 10 pin connector.*
- ***If pin 6 is already populated:** Splice the violet wire ("KEY SW PWR") into the existing wire populating pin 6 (Figure 53).

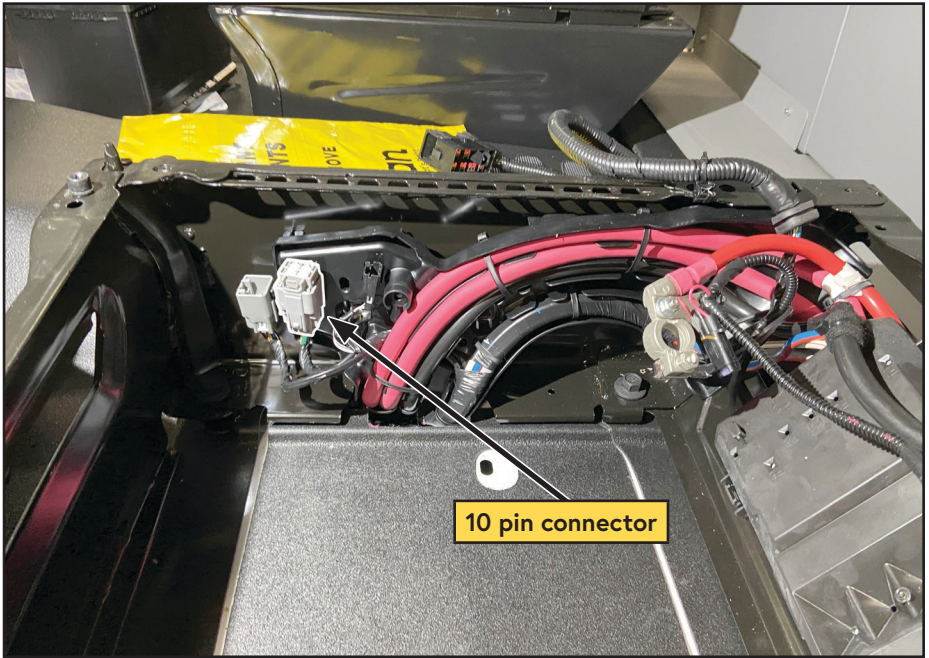

Figure 53 — Connect key switch power

- Locate connector C2280G in the Body Control Module (BCM) to the left of the steering column (Figure 54).

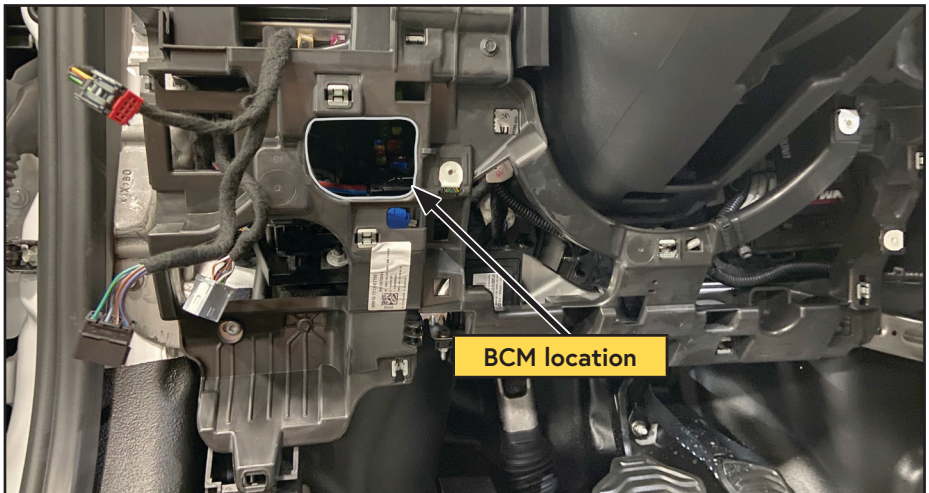

Figure 54 — BCM location

- Disconnect the C2280G connector and locate the white wire at pin 9 (CAN L), and the blue wire at pin 10 (CAN H) (Figure 55).

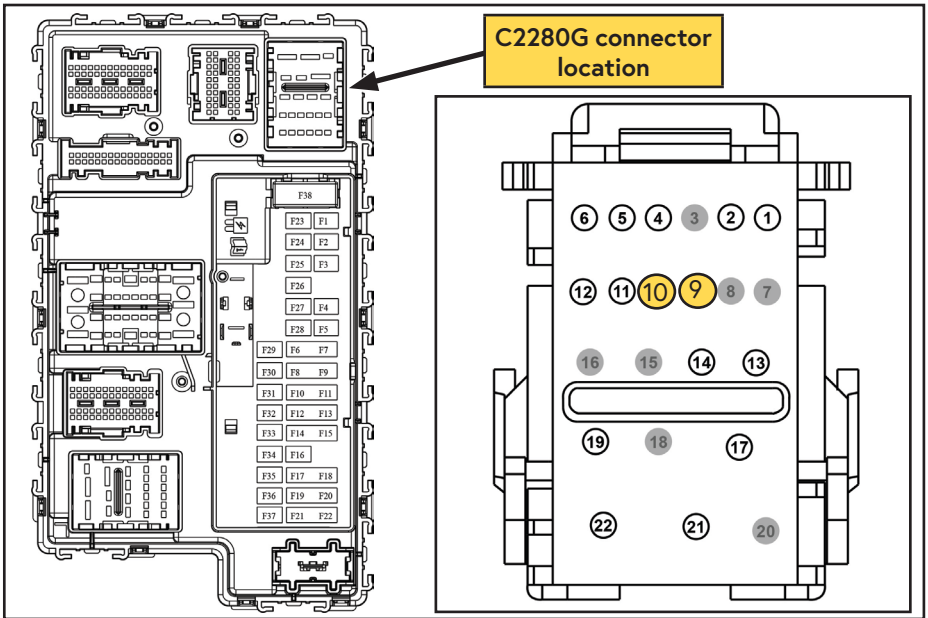

Figure 55 — BCM and C2280G connector

- Using the supplied Posi-Taps, splice (see page 41 for Posi-Tap instructions):*
 - *The grey wire from the DTC to the wire at pin 9 (CAN L).
 - *The blue wire from the DTC to the wire at pin 10 (CAN H).
- Using a cable tie, mount the Controller in the cavity of the BCM (Figure 56).

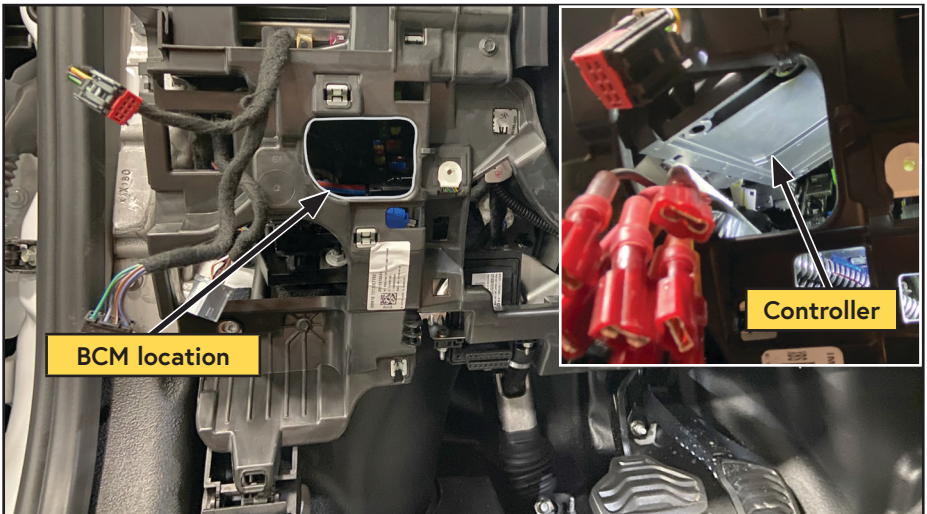

Figure 56 — Mount Controller

Engine Bay Wiring



The compressor and WHASP Tank pressure sensor connectors are identical. Ensure the harness labeled "COMPRESSOR PRESSURE SENSOR" is the one routed through the firewall.

- Route the following harnesses behind the dashboard and glove compartment to the passenger side of the vehicle (Figure 57, Figure 58):*
 - *TEMPERATURE SENSOR T1.
 - *COMPRESSOR CLUTCH.
 - *COMPRESSOR PRESSURE SENSOR.

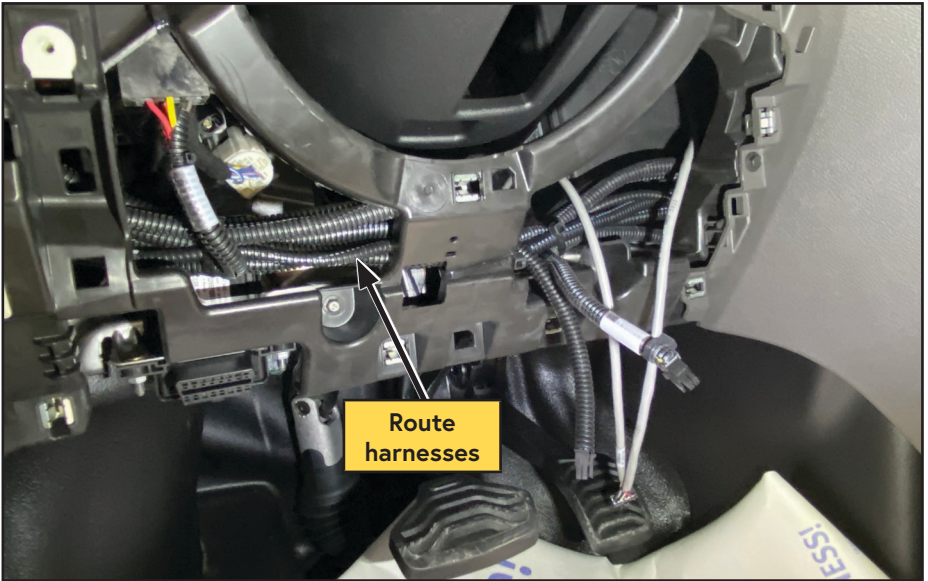

Figure 57 — Route engine bay harnesses

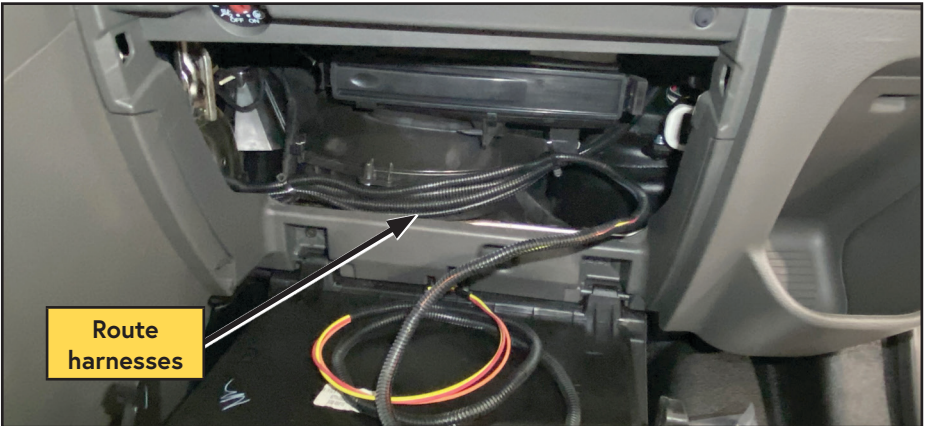

Figure 58 — Route engine bay harnesses

- Pass the harnesses into the engine bay via the firewall grommet.
- Route the harnesses toward the passenger side fender, and down toward the compressor.
- Using cable ties and/or rubber coated P-clips, secure the harnesses to the OEM harnesses/hoses.
- Continue to follow the hose routing over to the compressor.
- Connect the TEMPERATURE SENSOR T1 harness to the matching connector on the compressor.
- Connect the COMPRESSOR CLUTCH harnesses to the matching connector on the compressor.
- Connect the COMPRESSOR PRESSURE SENSOR harness into the pressure sensor on the "T" fitting located near the compressor.
- Pull any excess harness into the cab, coil it, and secure it safely out of the way.
- Using cable ties and/or rubber coated P-clips, secure the harnesses.

WHASP Tank Wiring

- Route the following harnesses to the rear of the vehicle to where the WHASP Tank is located:
 - *WHASP TANK FAN & BLOWDOWN SOL.
 - *VR40: WHASP TANK PRSS SENSOR.
- Plug the "VR40: WHASP TANK PRSS SENSOR" harness into the pressure sensor on the WHASP tank.
- Plug the "WHASP TANK FAN" harness into the fan on the WHASP tank.
- Plug the "BLOWDOWN SOL" harness into the solenoid on the WHASP tank.
- Coil any excess harness and secure it safely out of the way.
- Using cable ties and/or rubber coated P-clips, secure the harnesses.

Telematics Integration (Optional)

VMAC's advanced digital controls include an Upfitter harness connection for 3rd party telematics systems to read CAN data from the VMAC system.

Telematics System Requirements

- CAN 2.0 running at 500 kbps baud.
- J1939.
- Integration of PGNs from VMAC's VCAN protocol.
Note: VMAC's VCAN protocol is available to telematics integration engineers upon request, please contact VMAC Technical Support.

If additional support is required, contact VMAC sales to book an initial consultation with a member of our engineering team.

Phone: (877) 912-6605

Email: sales@vmacair.com

- The supplied VMAC display box contains the 120 Ω termination resistor and has CAN packet acknowledgment.
- If the supplied VMAC display box is not used the following are required:
 - 120 Ω termination resistor across CAN signal lines.
 - CAN packet acknowledgement.
 - The 3rd party telematics system must support CAN message acknowledgment (must not operate in silent mode).

Telematics Integration

- 1) Connect the 3rd party telematics system (not supplied) to the VMAC system via the Upfitter harness (see "Upfitter Port (16-pin black microfit connector)" on page 37).
*Connect the 3rd party telematics system within 36 in of the Controller. If this is not possible, contact VMAC tech support for assistance.
If the supplied Display is NOT used, add 120 Ω resistor between CAN H and CAN L near the 3rd party telematics system.*
- 2) Ensure both systems share a good ground.
- 3) Program the 3rd party telematics system with VMAC VCAN PGNs (interpretation of VMAC CAN messages). Refer to the 3rd party telematics documentation.
- 4) Apply power to the system by turning the vehicle key to the "ON" position. Observe telematics data on the telematics system (regardless of whether the VMAC system is running or not).

Remote Start Integration (Optional)



The "system on" command is registered after 3 seconds. VMAC recommends programing 3rd party controls or relay actuation for 4 seconds to allow sufficient time for the command to register.

A remote start/stop option is available on a signal line provided in the upfitter harness. This signal line can be connected to a momentary switch, a low-side driver output of a 3rd party controller, or a relay.

Momentary switch

Connect a momentary switch between the green and black wires labeled "ON/OFF CTRL" on the Upfitter Interface harness. Press and hold the switch for 3 seconds to start the system. Press and release the switch to stop the system.

3rd Party Controller

Connect the black wire labeled "ON/OFF CTRL" on the Upfitter Interface harness to a low-side driver output of a 3rd party controller. To start the system, use the output to pull the signal line low for 4 seconds. To stop the system, use the output to pull the signal line low momentarily.

Relay

Connect the black wire labeled "ON/OFF CTRL" on the Upfitter Interface harness to a relay contact. Connect the other relay contact to ground. To start the system, activate the relay to pull the signal line low for 4 seconds. To stop the system, activate the relay to pull the signal line low momentarily.

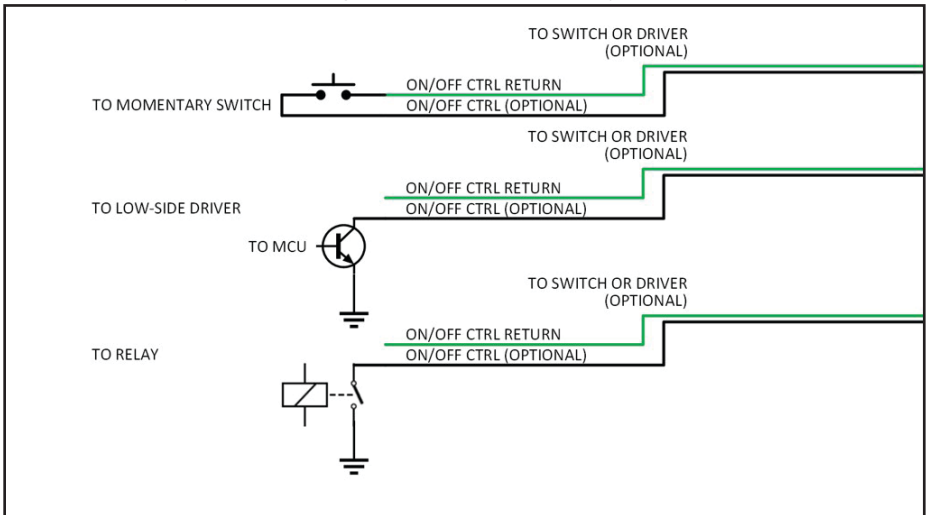

Figure 59 — Remote start integration

Installing the Air Filter and Power Steering Reservoir

- Mount the VMAC air filter assembly to the supplied bracket using the supplied M6 nylon lock nuts (Figure 60).

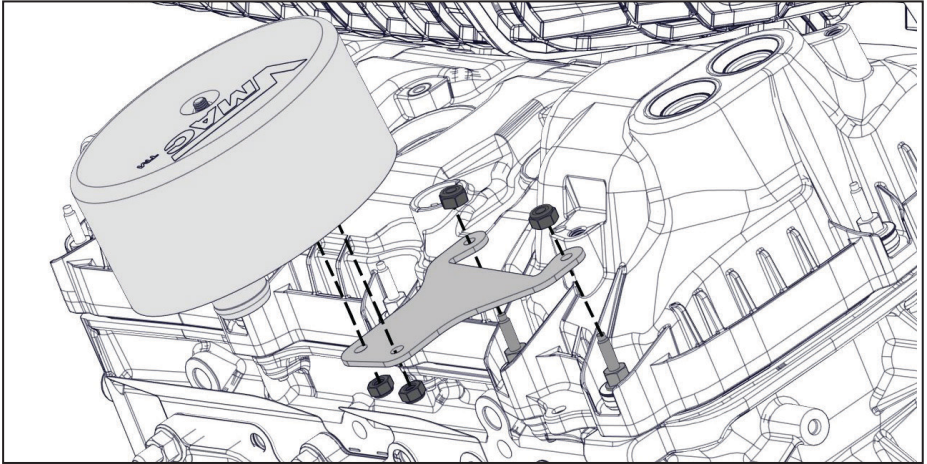

Figure 60 — Air filter and bracket
(A/C compressor removed for clarity)

- Using the (x2) supplied M5 nuts, mount the VMAC air filter and bracket assembly to the front valve cover studs (Figure 60).
- Cut 8 in from the straight end of the intake hose assembly (Figure 61).

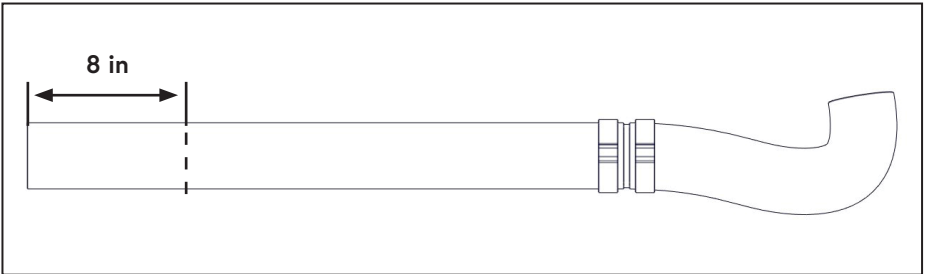

Figure 61 — Modify air intake hose

- Connect the compressor intake tube to the spigot on the air filter assembly and secure it with a hose clamp.

Completing the Installation

- Reinstall the coolant valve.
- Using the OEM fastener, secure the flat cable tray bracket to the oil pan (Figure 62).

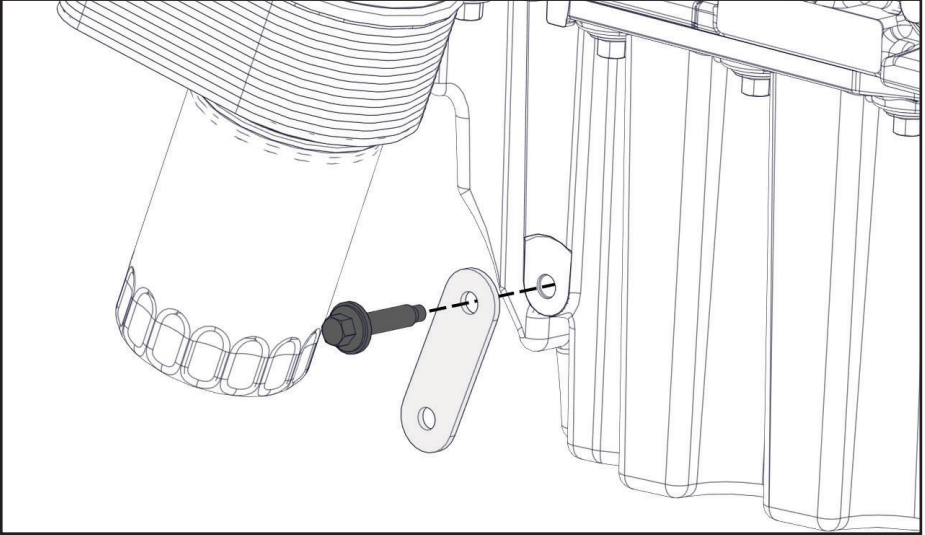

Figure 62 — Install driver side cable tray bracket

- Using the supplied fasteners, secure the cable tray to the bracket (Figure 63).

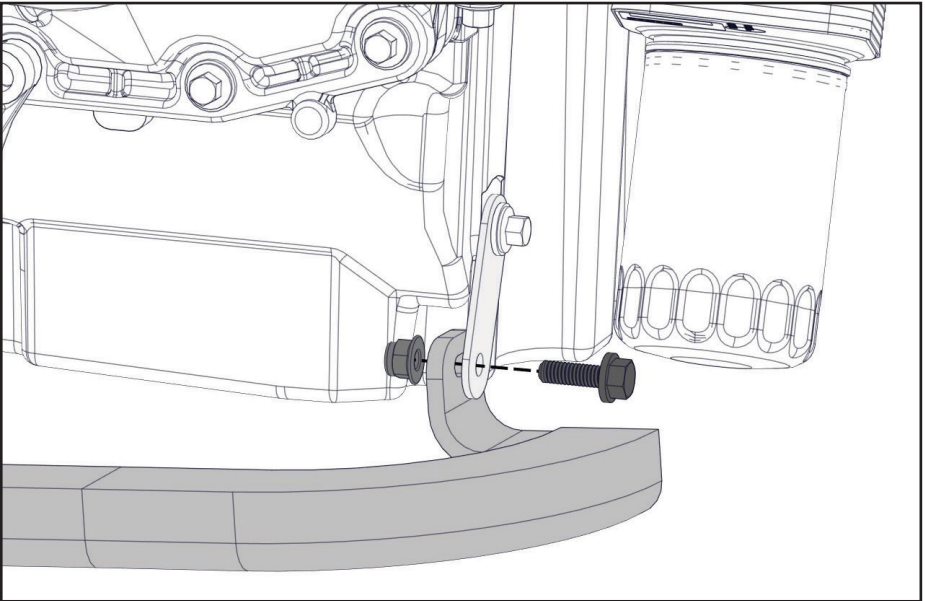

Figure 63 — Secure cable tray

- Using the supplied fasteners, secure the cable tray to the bracket (Figure 64).

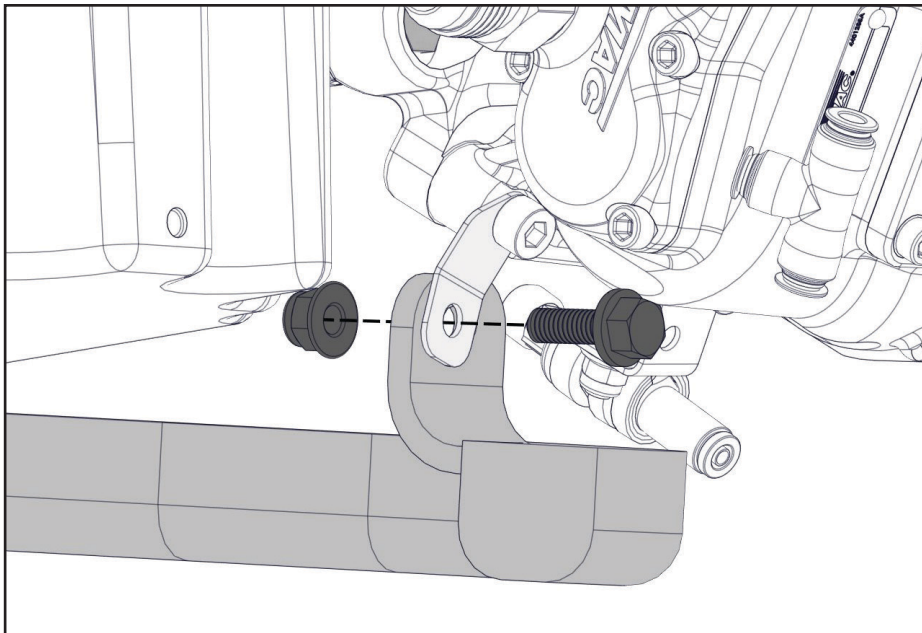

Figure 64 — Secure cable tray



If required, modify the center console to ensure the VMAC harnesses do not get crimped or pinched.

- Reinstall the center console.
- Check all VMAC and OEM wiring to ensure it will not contact any hot, sharp or moving components and will not interfere with the operation of the vehicle. Secure all wiring with rubber coated P-clips, cable ties and loom as required.
- Check all VMAC and OEM hoses and tubes to ensure they will not contact any hot, sharp or moving components and will not interfere with the operation of the vehicle. Secure all hoses and tubes with rubber coated P-clips, cable ties and loom as required.
- Reinstall the headlight (if removed).
- Reinstall the coolant overflow bottle.
- Reconnect the batteries and install the cover.
- Reinstall the driver seat.
- Reinstall the seat electrical connector.
- Replace all dashboard panels and kick plates that were removed.

- Affix the safety and operational instruction decal in an obvious location so that it can be seen by vehicle operators. A good spot for this is usually on the inside of the door or on the panel underneath the steering wheel (Figure 65).



Figure 65 — Advisory decal

- Install the VMAC belt routing decal in a suitable location under the hood (Figure 66).

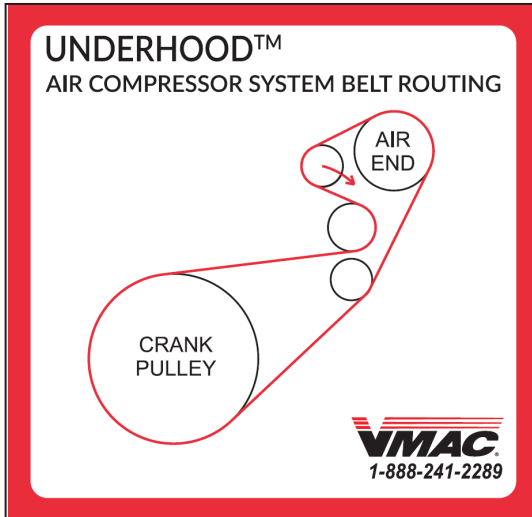

Figure 66 — Belt routing decal
(actual belt routing label may differ)

- Affix the safety and operational instruction decal in an obvious location so that it can be seen by vehicle operators. A good spot for this is usually on the inside of the door or on the panel underneath the steering wheel (Figure 67).

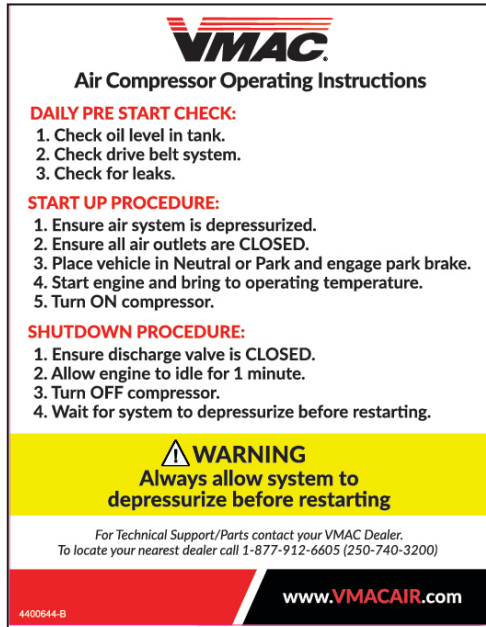



Figure 67 — Operating Instruction decal

 **The System Identification Plate must be attached to the vehicle at the time of installation. This plate provides information that allows VMAC to assist the operator with parts and repairs, and specific technical information.**

- Locate an area in the engine bay where the System ID plate will be easily noticed.
- Mark and drill (x2) 7/64 in holes and secure the plate with the supplied self-tapping screws (Figure 68).



Figure 68 — System Identification Plate

Air Receiver Tank



Pressure in the air receiver tank will not be relieved when the compressor system blows down. This is normal operation. Prior to performing any service work on the system, discharge any stored air in the air receiver tank.



The VMAC WHASP Tank has a built-in check valve. Use of an additional check valve is not required and may cause erratic performance.

The VMAC compressor system automatically depressurizes when it is shut-down. The WHASP Tank has a built in 1-way check valve which prevents blow back and moisture from the receiver tank entering the WHASP Tank. Installation of an additional check valve will cause erratic performance.

While the air receiver tank can be installed at any height in relation to the WHASP Tank, the discharge hose running from the WHASP Tank must be installed as high as possible on the air receiver tank to prevent problems with condensation that may have accumulated in the receiver tank (Figure 69).

Drain the condensed water from the receiver tank daily.

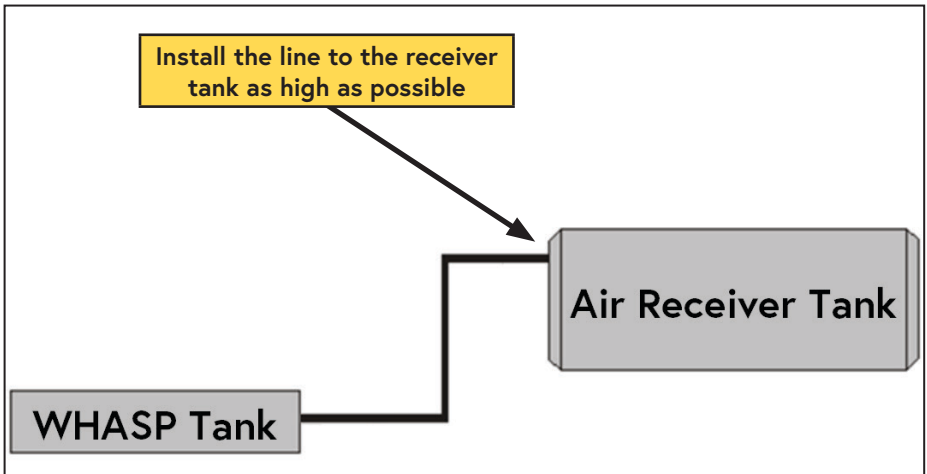

Figure 69 — Air receiver tank

Recommended Accessories

While the compressor system will function without the following accessories, VMAC strongly recommends their use for optimal performance.

See the "Accessory Product" section of this manual on page 73 for a list of products available for purchase through VMAC.

Larger Air Receiver Tank

A larger capacity air receiver tank provides a larger buffer as it gives the compressor time to react by increasing the engine speed and producing air before the tool stalls. It also has the advantage of lowering the duty cycle of the compressor system.

(This application requires a minimum air receiver tank size of 6 USG).

Pressure Gauge

While not critical to system performance, a pressure gauge is important for fine tuning the system and simplifies any potential troubleshooting.

Install a 200 psi pressure gauge downstream of the VMAC system's air discharge.

Pressure Regulator and/or Lubricator or FRL

The compressor can produce air pressures up to approximately 150 psi (1035 kPa). It is the responsibility of the user to know the pressure and air flow requirements of the tools powered by the air compressor system.

An appropriate air pressure regulator and lubricator can be installed downstream of the air discharge valve. Failure to regulate the air pressure may cause damage to the tool.

Testing the Installation



The "Product Registration" message is intended for the end user as a reminder to register their warranty with VMAC.

This message should not be cleared by an Upfitter or third party installer!

Refer to the UNDERHOOD 40 Owner's Manual for instructions on how to clear this reminder.



For an overview of the display box and basic operating instructions turn to "Basic Operation" on page 64.

Control System Testing

Turn the ignition to "ACC":*

- ***Key Switch:** Turn the key two clicks.
- ***Push button Start:** Without depressing the service brake, push the START button twice.
- Press "MENU" and use the navigation buttons ("- " and "+ ") to navigate to "Sys Status".
- Navigate to "Controller Test Mode" and press "ENTER" to set the value to "ON".
Note: *While in "Controller Test Mode", the system will not be run until TEST mode has been disabled.*
- Navigate back to the main menu.
- Navigate to "DTC Status".
- Scroll to "Park Brake Signal".*
 - *While observing the display, engage and disengage the park brake several times.
 - *When engaged, the display should indicate "ON", when disengaged, the display should indicate "OFF".
- Scroll to "PRNDL Signal".*
 - *While observing the display, shift the vehicle into all gear positions several times.
 - *The display should indicate "Not in Park" when the gear selector is in reverse, drive, or low. The display should indicate "Park" only when the gear selector is in park.
Note: *Neutral is vehicle dependent and could display either "Park" or "Not in Park". The VMAC system is safe to operate provided the vehicle is not in gear.*
- Navigate back to the main menu.
- Navigate to "Sys Status".
- Navigate to "Output Status".

- Scroll to "Comp" (this test will only work with the vehicle off).*
 - *With the hood open, press "ENTER" to toggle the clutch on.
 - *Verify the clutch is engaged. The clutch engagement is audible though it may be necessary to have an assistant listen while performing this test. Alternatively, clutch engagement can be verified by attempting to rotate the center of the clutch by hand (the compressor should turn over by hand when the clutch is not engaged).
 - *Verify the measurement on the display box is between 3,000 mA and 5,000 mA.
 - *Press "ENTER" to toggle the clutch off. Verify the measurement on the display box is between 0 mA and 100 mA.
- Scroll to "Fan".*
 - *Press "ENTER" to toggle the WHASP Tank fan ON. Verify the WHASP tank fan turns ON. **Note:** *The display will always show 0 mA as this sensor is not currently used.*
 - *Press "ENTER" to toggle the fan OFF. Verify the WHASP tank fan turns OFF.
- Scroll to "BD Sol".*
 - *Press "ENTER" to toggle the WHASP Tank blowdown solenoid ON.
 - *Verify the WHASP tank solenoid activates. The solenoid engagement is audible though it may be necessary to have an assistant listen while performing this test.
 - *Verify the measurement on the display box is between 530 mA and 880 mA.
 - *Press "ENTER" to toggle the WHASP Tank blowdown solenoid OFF. Verify the measurement on the display box is between 0 mA and 100 mA.
- Navigate back to the main menu.
- Navigate to "Sys Status".
- Navigate to "Controller Test Mode" and set the value to "OFF".
- Check that the compressor oil level at the WHASP Tank sight glass is correct.
- Perform a final inspection of the installation to ensure everything has been completed.
- Perform a final belt alignment check.
- Check all wiring for security and protection. Ensure nothing is touching the compressor body.
- Ensure all of the compressor outlets are closed.
- Ensure the parking brake is engaged and the transmission is in "PARK".
- Start the engine.
- Allow the vehicle to reach operating temperature.

- Press and hold the "ENTER"/Power button for 3 seconds to power the system on (the power indicator on the display should change from "OFF to "ON").*
- *Remote Start:** Refer to page 52, or the documentation provided by the Upfitter for remote start instructions.



The first time the VMAC system is run, the DTC will perform an auto-calibration as it adjusts to the vehicle's tune, this process can take up to 3 minutes. During this time, "DTC calibrating" will appear on the display box.

- Once the system is turned on, the DTC will enter its auto-calibration mode and "DTC calibrating" will appear on the display box.*
 - *Open the ball valve.
 - *Wait for the DTC calibration to complete and the display box to indicate "RUNNING".
 - *Close the ball valve.
- Observe the compressor while it is operating to ensure the belts rotate properly, pulleys rotate smoothly and nothing is rubbing or contacting hot parts.
- Check the system for leaks.
- Once the system has reached full system pressure (150 psi):*
 - *The engine speed should reduce to OEM base idle.
 - *The clutch should disengage.
 - *"STANDBY" should appear on the display box.
- Press and release the "ENTER"/Power.*
 - *The display box will change to "OFF".
- Shut down the engine.
- Ensure the VMAC system blows down.
- Check the compressor oil level after the engine has been shut down and the oil level has had time to stabilize.



Ensure any stored air is drained from the system prior to adding oil.

- Add oil as necessary to bring the level to the "FULL" line in the sight glass and check for leaks.

Final Testing

Ensure the following has been completed:

- Operate the system with an air tool (or the VMAC Air Test Tool with the appropriate orifice installed) for at least 1/2 hour (1 hour preferred).



The WHASP Tank cooling fan is thermostatically controlled, and may start or stop without warning.

- Observe the compressor while it is operating to ensure the belts rotate properly, pulleys rotate smoothly and nothing is rubbing or contacting hot parts.
- Check the system for leaks.
- Road test the vehicle for approximately 20 km (14 miles).
- Perform final check to ensure the belts rotate properly, pulleys rotate smoothly and nothing is rubbing or contacting hot parts and check for any leaks.

Once the engine is turned off and the system has cooled:*

- *Check all components, connections and fasteners.
- *Check the compressor oil level.

Basic Operation



This information is intended to assist the installer with system testing, which takes place in the following chapter.

Refer to the UNDERHOOD 40 "with Advanced Digital Controls" Owner's Manual for in depth operating instructions including a description of the various menus, diagnostic information, and adjustable parameters.

- The display box will light up when the vehicle ignition is "ON" or "ACC".
- Use the navigation buttons to scroll through the menus.
- Press and release the "ENTER" button to make a selection.
- Press and hold the "ENTER"/Power button for 3 seconds to power the VMAC system on.
 - The power indicator on the display should change from "OFF" to "ON".
- Press and release the "ENTER"/Power to shut the system down.

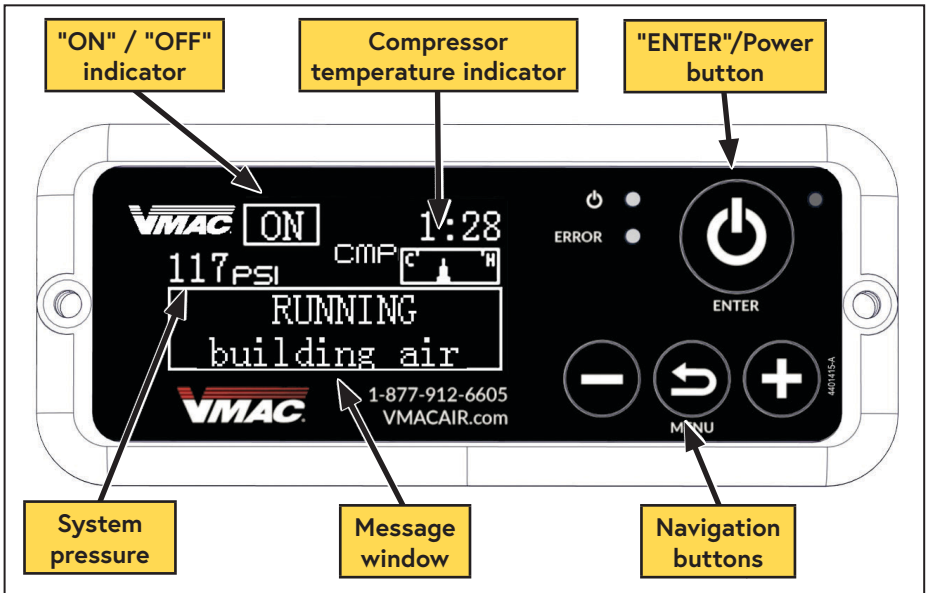

Figure 70 — Display box

Normal operating messages



Figure 71 — Display box messages

Starting the compressor / Normal Operation

- To start the system, press and hold the "ENTER"/Power button for 3 seconds to power the system on.*
 - ***Remote Start:** Refer to page 52, or the documentation provided by the Upfitter for remote start instructions.
- Once the system is on, the system will either build air (if system pressure is low) or will enter standby (if already at system pressure).
- When the system is building air, the system will first go through a start routine to ensure the compressor starts under optimal conditions.
 - The engine speed will elevate to the programmed "Starting RPM" (usually in the range of 800 rpm to 1,200 rpm). This parameter is located in the DTC status menu.
 - The blowdown pressure sensor is checked to ensure pressure in the compressor is less than 10 psi.
- Once the above conditions are confirmed, the compressor clutch will engage and the system will start building air.
- Engine speed will elevate to "maxRPM" (this is defined by the VMAC system specific to the vehicle application). See "System Adjustment, Optimization, and Basic Parameters" on page 67.
- Air may be heard to escape from the blowdown muffler on the WHASP Tank for up to 20 seconds as internal pressure is built.
- The system will continue to build air until system pressure is achieved (150 psi by default) and the system will enter Standby mode.

Standby

When the system is in Standby:

- Engine speed will drop to base idle.
- The compressor clutch will disengage.
- The WHASP Tank will blow down.
- The Controller will monitor the system air pressure. If the air pressure drops below 120 psi, the system will repeat the process above to build air.

Shutting Down the Compressor

- Close all open air valves/tools and allow the system to build to full system pressure (factory default 150 psi).
- Ensure engine speed has dropped to base idle for at least 10 seconds.
- Press and release the "ENTER"/Power button.*
 - ***Remote Start** (see page 52): Actuate and release the Remote Start switch.

Performance Testing

System operation can be tested using the tools that will be operated by the system or by using the VMAC Test Tool (A700052) with the 40 cfm (5/32 in) orifice in the outlet to simulate tool use (Figure 72).

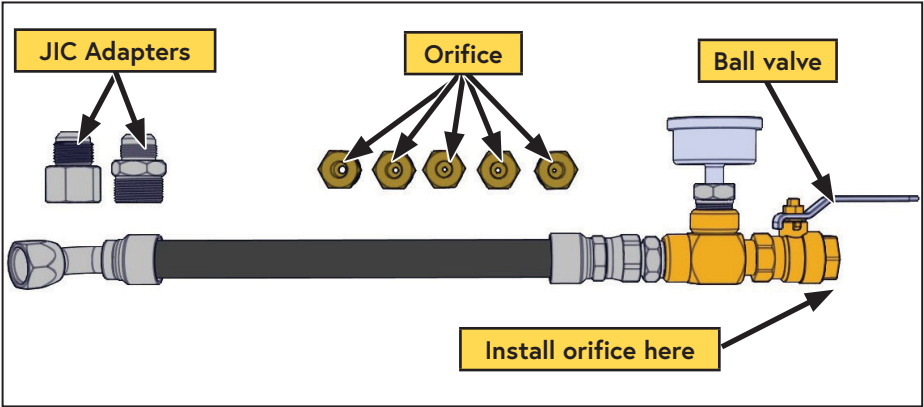

Figure 72 — A700052 VMAC Air Test Tool



Disconnect all downstream equipment (hose reels, etc.) and connect the test tool directly to the discharge fitting on the WHASP Tank. Ensure there are no leaks in the test tool. The system may not idle down if there are leaks in the lines or fittings.

- Install the VMAC test tool at the system outlet with the 40 cfm (5/32 in) orifice.
- Ensure the ball valve is closed.
- Place the transmission in "PARK" and fully apply the park brake.
- Allow the engine to run until it is at operating temperature.
- Turn on the air compressor system and allow it to operate until the oil is warm.
- Observe the pressure gauge. Pressure should be approximately 150 psi.

Open the ball valve on the test tool and observe the engine tachometer:

- Engine speed should increase to the default maximum VMAC rpm (see "System Adjustment, Optimization, and Basic Parameters" on page 67).
- Close the air valve slowly to allow the system pressure to rise. When the pressure reaches system pressure (default 150 psi), the system will disengage the compressor clutch and reduce the engine speed to base idle.
- Once the system pressure is at maximum pressure, slowly open the ball valve on the test tool until the pressure on the gauge begins to drop. Engine speed should ramp up to default maximum VMAC rpm when the pressure drops below 120 psi.

System Adjustment, Optimization, and Basic Parameters



This page is provided for the convenience of the Upfitter/installer. For a complete list of parameters and system adjustments, refer to the Refer to the UNDERHOOD 40 "with Advanced Digital Controls" Owner's Manual

The cfm generated by this system is directly related to the vehicle's engine speed. VMAC configures this system for optimum performance at maximum cfm. In applications where maximum cfm is not required, or noise is a concern, the system can be adjusted to reduce the maximum VMAC rpm.

- With the VMAC system running and in "STANDBY", mode, navigate to "Sys Parameters".
- Adjust "Max RPM" to the desired value.



If tools are not performing as expected (low performance, tool is stalling, etc.), increase the "Max RPM" and retest.

Parameter	Default	Description
Set System Pressure	150 psi	Adjusts the maximum system pressure.
Restart Pressure	120 psi	Adjusts the system restart pressure.
Min RPM	Do not adjust	Adjust the RPM at which the DTC calibration occurs.
Max RPM	2,650 rpm	Adjusts the maximum engine speed used when the compressor is building air. <ul style="list-style-type: none"> • The default value produces optimal performance and generates maximum cfm. • Lower "Max RPM" values will lower fuel consumption and achieve quieter operation, but will result in reduced cfm output To change: Main menu -> System Parameters -> Max RPM
DTC Factory Reset (Max RPM Reset)	—	To reset: Main menu -> System Parameters -> DTC Factory Reset
Maximum cfm @ default max rpm	40 cfm	—
Normal operating temperature range	104 °C (220) to 127 °C (260° F)	—
Over temperature shut down	143 °C (290 °F)	—
Fan on/off temps:	—	The WHASP Tank cooling fan is thermostatically controlled. The fan turns on at 88 °C (190 °F) and turns off at 66 °C (151 °F).

VMAC - Vehicle Mounted Air Compressors

VMAC Technical Support: 888-241-2289

VMAC Knowledge Base: kb.vmacair.com

Errors and Error Codes

Some rare error codes that are not listed below will appear as a number in hexadecimal format. The last 2 digits reflect the error code while the first 2 digits reflect engineering codes. If an error code ever appears in this format, contact VMAC technical support.



Figure 73 — Error message

Error Code	Hex Error	Display	Fault	Possible Problem(s)
3	xx03	UHC NOT RESP	Controller not responding.	<ul style="list-style-type: none"> • Display box harness not plugged in fully or wiring/connector damaged.
4	xx04	UHD NOT RESP	Display not responding	<ul style="list-style-type: none"> • Display box cable too long. • Controller not powered. • Excessive CAN traffic due to 3rd party equipment connected to VCAN bus. • High power radio frequency interference. • VCAN bus module damaged in either the Controller or the display box.
5	xx05	DTC NOT RESP	DTC not responding	<ul style="list-style-type: none"> • DTC harness not plugged in fully or wiring/connector damaged (including loop back connector). • DTC pedal harness not plugged in and/or damaged. • Excessive CAN traffic due to 3rd party equipment connected to VCAN bus. • High power radio frequency interference.
8	xx08	CLUTCH OPEN	No current on compressor clutch/solenoid.	<ul style="list-style-type: none"> • Clutch wire unplugged or damaged. • Harness damaged. • Bad clutch ground.

Error Codes (Cont.)

Error Code	Hex Error	Display	Fault	Possible Problem(s)
9	xx09	CLUTCH SHORT	Short circuit on compressor clutch/solenoid.	<ul style="list-style-type: none"> Clutch wire damaged. Harness damaged.
10	xx0A	CLUTCH CURRENT	High current on compressor clutch/solenoid.	<ul style="list-style-type: none"> Clutch wire damaged. Harness damaged.
11	xx0B	CMP TEMP OPEN	Compressor temperature sensor unplugged or not detected.	<ul style="list-style-type: none"> Test temperature probe. Repair wiring to probe.
12	xx0C	CMP TEMP SHORT	Compressor temperature sensor shorted.	Repair wiring to probe.
13	xx0D	CMP OVERTEMP	Compressor oil is too hot (above 144 °C / 291 °F).	<ul style="list-style-type: none"> Low compressor oil level. Faulty or crushed cooler hoses. Cooling fan not operating. Insufficient air-flow or ventilation. Failed temperature probe or faulty electrical connection. Incorrect compressor oil used.
14	xx0E	CMP PRESS HIGH V	Pressure sensor signal voltage too high.	<ul style="list-style-type: none"> Pressure sensor damaged. Harness damaged, unplugged, or partially connected.
15	xx0F	CMP PRESS LOW V	Pressure sensor signal voltage too low.	<ul style="list-style-type: none"> Pressure sensor damaged. Harness damaged, unplugged, or partially connected.
16	xx10	OVERPRESSURE	Pressure over 180 psi.	<ul style="list-style-type: none"> Faulty pressure sensor. Clutch is seized on. Bent compressor shaft.
29	xx1D	RUNNING HOT	Compressor is running hot and approaching over temperature.	<ul style="list-style-type: none"> Fan or cooling system not working. Lack of service. Internal damage to the compressor.
30	xx1E	SCAVENGE PRESS	Scavenge blowdown pressure fault.	<ul style="list-style-type: none"> The two pressure sensor harnesses are reversed. Blowdown system is damaged. Blowdown valve blocked. Scavenge line blocked.

Error Codes (Cont.)

Error Code	Hex Error	Display	Fault	Possible Problem(s)
31	xx1F	BLOWDOWN	Blowdown is taking too long	<ul style="list-style-type: none"> Blowdown system is damaged. Blowdown valve blocked. Blocked or corroded blowdown muffler. Scavenge line blocked.
68	xx44	RPM LOW	Vehicle engine rpm too low.	Vehicle engine not running.
72	xx48	THROTTLE SHORT	Short circuit on Throttle output	<ul style="list-style-type: none"> Throttle output damaged. Harness damaged. DTC damaged.
73	xx49	VHCL NOT IN PARK	Vehicle is not in Park	Vehicle is not in Park
74	xx4A	PARK BRAKE	Vehicle Park Brake not applied.	Vehicle Park Brake not applied
75	xx4B	RPM CONTROL	<ul style="list-style-type: none"> Vehicle RPM control fault. Loss of RPM control. Very slow RPM response. 	<ul style="list-style-type: none"> Wrong DTC for application Engine at high idle due to cold temperature, charging, etc. Vehicle elevated idle feature enabled
152	xx98	BATT LOW V	Battery voltage too low (below 10.5V).	<ul style="list-style-type: none"> Voltage supply to system is excessively low. Controller harness damaged, unplugged, or partially connected.
153	xx99	BATT HIGH V	Battery voltage too high (above 15.5V).	Voltage supply to system is too high.
154	xx9A	VDD LOW	Controller internal 5V power supply voltage too low.	<ul style="list-style-type: none"> Voltage supply system excessively low. Short circuit on one of the Controller sensors.
191	xxBF	MCU EEPROM	Data corruption detected.	<p>Removing power from Controller while:</p> <ul style="list-style-type: none"> System is running Adjusting parameters/ settings
193	xxC1	MCU TEMP	Controller internal temperature too high: (above 83 °C / 181 °F), or too low (below -38 °C / -36 °F).	<ul style="list-style-type: none"> The Controller is getting too hot or too cold.

Error Codes (Cont.)

Error Code	Hex Error	Display	Fault	Possible Problem(s)
194	xxC2	MCU RESET	System reset due to brownout, watchdog timer, or other.	<ul style="list-style-type: none"> • Brown-out due to: <ul style="list-style-type: none"> ◦ Voltage supplied to system is excessively low. ◦ Bad harness connection. ◦ Short circuit on Controller sensor. • MCU code execution froze.
224	xxE0	DEVCxxx NOT RESP	VCAN receive message timeout.	See error code 3/4 on page 68.
225	xxE1	VCAN FAULT	VCAN bus fault detected.	<ul style="list-style-type: none"> • VCAN signal lines shorted, or one line open. • VCAN bus heavily congested • No message acknowledgment.
226	xxE2	VCAN HB TIMEOUT	VCAN heartbeat timeout.	<ul style="list-style-type: none"> • <i>If the display box was used to start the system:</i> Disconnected/reconnect the display box. • VCAN signal lines shorted, or one line open. • VCAN bus heavily congested. • No message acknowledgment.
232	xxE8	DTC: NO RPM	DTC error: no RPM signal (either from CAN or tach input).	<ul style="list-style-type: none"> • DTC harness connected to incorrect vehicle CAN wires. • Bad connection on DTC harness to vehicle CAN wires. • Wrong DTC for application.
233	xxE9	DTC: NO PRESSURE	DTC error: no pressure signal (either from VCAN or analog sensor).	Harness connecting DTC to Controller is damaged.
234	xxEA	DTC:RPM TOO HIGH	DTC error: vehicle engine rpm too high.	<ul style="list-style-type: none"> • Compressor clutch faulty. • Wrong DTC for application.
235	xxEB	DTC: BATT V HI/LO	DTC error: Battery voltage too low or too high.	<ul style="list-style-type: none"> • Bad power connection. • Controller to DTC harness damaged, unplugged, or partially connected. • Vehicle battery voltage too high or too low.

Error Codes (Cont.)

Error Code	Hex Error	Display	Fault	Possible Problem(s)
236	xxEC	DTC: NO VCAN	DTC error: no VCAN communication with Controller.	Harness connecting DTC to Controller is damaged.
237	xxED	DTC: WRONG FW	DTC error: wrong DTC firmware version.	Wrong DTC for application

Accessory Products from VMAC

Compressor Service Kits



**200 Hour or 6 Month Service Kit -
Part number: A700263**

Includes 4 L VMAC high performance compressor oil, oil filter, air filter, and next service due decal.

**400 Hour or 1-Year Service Kit -
Part number: A700264**

Includes 4 L VMAC high performance compressor oil, oil filter, air filter, spin-on oil separator, safety valve, muffler, and next service due decal.

Bulkhead Fittings

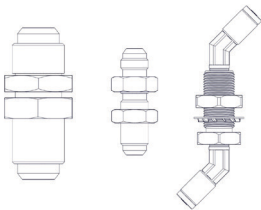

Part number: 3801095

Bulkhead fittings are used for passing the system discharge, oil, and scavenge hoses through the floor or body panels.

Includes:

- 3/4 in JIC bulkhead fitting P/N: 4900170.
- 3/8 in JIC bulkhead fitting P/N: 4900209.
- 1/8 in NPT bulkhead fitting P/N: 5000178.
- 2 x 45° 1/4 push-to-connect fittings P/N: 5000158.

Hose Fittings

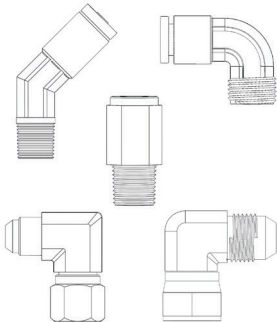

45° 1/4 push-to-connect fitting P/N: 5000158.

1/4 in push-to-connect fitting For PTFE scavenge tube.

90° 1/4 push-to-connect fitting P/N: 5000020.

1/4 in push-to-connect fitting For PTFE scavenge tube.

Straight 1/4 in push-to-connect fitting P/N: 5000012.

1/4 in push-to-connect fitting For PTFE scavenge tube.

90° 3/8 in hose fitting P/N: 4900117.

3/8 in hose fitting for Oil Return Hose.

90° 3/4 in hose fitting P/N: 4900043.

3/8 in hose fitting for Compressor Discharge Hose.

1/2 in x 50 ft Hose Reel

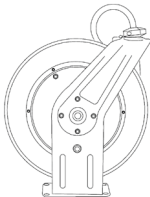

Part number: A700007

Spring-loaded 1/2 in x 50 ft hose reel; steel construction; full flow shaft and swivel for maximum performance.

6 Gallon Air Receiver Wing Tank

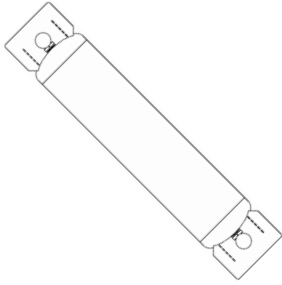

Part number: A300056

Air receiver tanks are used for lowering compressor duty cycle and removing water from compressed air; recommended for optimum operation of all VMAC Gas Driven, Diesel Driven, Hydraulic, and UNDERHOOD40 air compressors. Manufactured to FMVSS 121 standard; includes fittings, 170 psi pressure relief valve, and tank drain.

- Max pressure: up to 170 psi.
 - Dimensions: 32 in (81.3 cm) L x 8 in (20.3 cm) D.
 - Weight: 23 lb (10.4 kg).
-

10 Gallon Air Receiver Tank w/ Mounting Feet



Part number: A300047

Air receiver tanks are used for lowering compressor duty cycle and removing water from compressed air. Recommended for optimum operation of VMAC Hydraulic Air Compressors, VMAC Diesel Driven Air Compressors, UNDERHOOD40, UNDERHOOD70 – Green Series Air Compressors, and VMAC Multifunction Power Systems, which include standby mode; ASME certified; includes fittings, 200 psi pressure relief valve, tank drain, and 200 psi pressure gauge.

- Max pressure: up to 200 psi.
 - Dimensions: 30 in (76.2 cm) L x 10 in (25.4 cm) D.
 - Weight: 33 lb (15 kg).
-

35 Gallon Air Receiver Wing Tank

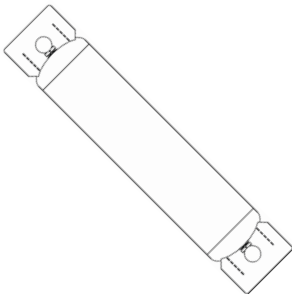

Part number: A300010

Air receiver tanks are used for lowering compressor duty cycle and removing water from compressed air. Recommended for optimum operation of VMAC Diesel Air Compressors, Hydraulic Air Compressors, UNDERHOOD40, UNDERHOOD70 – Green Series Air Compressors, and VMAC Multifunction Power Systems, which include standby mode; ASME certified; includes fittings, 200 psi pressure relief valve, tank drain, and 200 psi pressure gauge.

- Max pressure: up to 200 psi.
 - Dimensions: 73 3/4 in (187.3 cm) L x 14 in (35.6 cm) D.
 - Weight: 95 lb (43.1 kg).
-

UNDERHOOD 70 Air Aftercooler

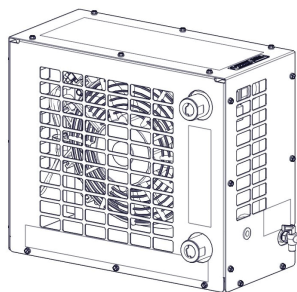

Part number: A800070

Improves tool performance and extends the life of air tools; removes up to 80% of water from compressed air; includes automatic water drain.

- Max air flow: 70 cfm / 175 psi.
- Port size: 3/4 in NPT inlet and outlet.
- Electrical: 12 V.
- Dimensions: 17 in (43.2 cm) L x 8.0 in (20.3 cm) W x 14.5 in (36.8 cm) H .
- Weight: 35 lb (15.8 kg).

Filter Regulator Lubricator (FRL) – 70 cfm

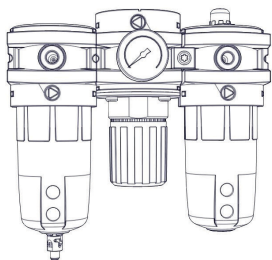

Part number: A700151

Extends the life of air tools; filter removes contaminants from the compressed air, adjustable regulator can reduce air pressure going to tools, lubricator adds atomized tool oil to the air stream to lubricate air tools (Tool oil not included).

- Max air flow: up to 70 cfm / 150 psi.
- Port size: 3/4 in NPT inlet and outlet.

Remote Muffler

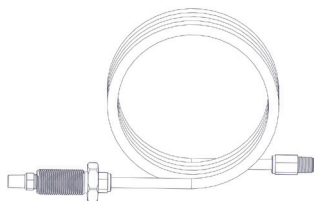

Part number: A700224

The A700224 WHASP remote mount muffler kit is designed to relocate the blowdown muffler to an external location. This is recommended for applications where the WHASP Tank will be located inside of a van or service body, the remote mounted muffler will reduce cabin noise when the compressor blowdown operates, and will ensure any oil vapor will be safely discharged outside of the vehicle.

Display Harness Extension

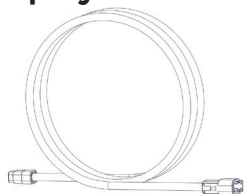

Part number: 3530861

This display harness extension provides an additional 10 ft of cable which allows for greater flexibility in locating the display Panel.

Warranty Registration

This form must be fully completed and returned to VMAC at the time the vehicle is put into service. Warranty may be void if this form is not received by VMAC within 3 months of receiving the vehicle, or 200 hours of operation, whichever occurs first.



VMAC's Warranty policy and registration can be viewed online at:

www.vmacair.com/warranty

Product Information

System Identification Number: V _____

Compressor Serial Number: P _____

Owner / End User Information

Company Name: _____

City: _____ State / Province: _____

Phone: (____) ____-_____

Email Address: _____

Date vehicle was put into service: ____/____/____
Day Month Year

Installer Information

Installer Company Name: _____

City: _____ State / Province: _____

Submitted by

Name: _____ Phone: (____) ____-_____

Email Address: _____

Vehicle Information (Optional)

Unit: _____ Year: _____

Make: _____ Model: _____

Vehicle Identification Number: _____

Manufactured by



888-241-2289



tech@vmacair.com



877-740-3202



warranty@vmacair.com



www.vmacair.com



kb.vmacair.com



1333 Kipp Road, Nanaimo, B.C., V9X 1R3 Canada