

# ***UNDERHOOD***™ **40** AIR COMPRESSORS



## Installation Manual for VMAC System

V400034

2023+ Ford Transit  
3.5 L Gas PFDI Duratec

[www.vmacair.com](http://www.vmacair.com)



# Table of Contents

Safety .....	3
Warranty .....	4
General Information.....	6
Preparing for Installation .....	8
Installing the main bracket and Compressor .....	14
Installing the Waste Heat Air Separator Package (WHASP) Tank ....	17
Installing the Bulkhead Fittings.....	20
Hose Requirements .....	23
Connecting the Hoses .....	24
Adding Oil to the System .....	31
Installing the Control System.....	32
Installing the Air Filter and Power Steering Reservoir.....	48
Completing the Installation .....	49
Air Receiver Tank.....	51
Recommended Accessories .....	52
Testing the Installation.....	53
Performance Testing and System Adjustments.....	56
Digital Throttle Control Operation and Adjustments .....	57
Accessory Products from VMAC.....	59
Warranty Registration.....	64

Revision	Revision Details	Revised by	Checked by				Implemented
			Eng.		Tech.	Qual.	
			Mech.	Elec.			
B	ECN: 23-252 Update application information and electrical installation.	MSP	N/A	ASE	MSP	N/A	12 Jan. 2024

## Additional Application Information

- Use of an air receiver tank (minimum 6 USG) is required with this application.
- 2023+ Ford Transit, 3.5 L Gas PFDI Duratec engine.
- For 3.5 L Ecoboost, refer to the V400029 system.
- Dual alternator vehicles must be converted to single alternator prior to proceeding with the VMAC installation.
- Vehicles equipped with push button park brake will need to purchase VMAC accessory A700327 (Upfitter Interface Module).

## Registered Trademarks

All trademarks mentioned in this manual are the property of their respective owners. VMAC's use of manufacturers' trademarks in this manual is for identification of the products only and does not imply any affiliation to, or endorsement of said companies.

**Loctite®**, **Loctite® 242** and **Loctite® 567** are registered trademarks of Henkel AG & Company KGaA.

**Eaton Aeroquip®** is a registered trademark of EATON AEROQUIP INC.

**Ford®** and **Duratec®** are registered trademarks of Ford Motor Company.

## Important Information

The information in this manual is intended for certified VMAC installers who have been trained in installation and service procedures and/or for anyone with mechanical trade certification who has the tools and equipment to properly and safely perform the installation or service. Do not attempt installation or service without the appropriate mechanical training, knowledge and experience. Follow all safety precautions. Any fabrication for correct fit in modified vehicles must follow industry standard "best practices".

## Notice

Copyright © 2023 VMAC Global Technology Inc. All Rights Reserved. These materials are provided by VMAC for informational purposes only, without representation or warranty of any kind, and VMAC shall not be liable for errors or omissions with respect to the materials. The only warranties for VMAC products and services are those set forth in the express warranty statements accompanying such products and services, if any, and nothing herein shall be construed as constituting an additional warranty. Printing or copying of any page in this document in whole or in part is only permitted for personal use. All other use, copying or reproduction in both print and electronic form of any part of this document without the written consent of VMAC is prohibited. The information contained herein may be changed without prior notice.

**Printed in Canada**

# Safety

## Important Safety Notice

The information contained in this manual is based on sound engineering principles, research, extensive field experience and technical information. Information is constantly changing with the addition of new models, assemblies, service techniques and running OEM changes. If a discrepancy is found in this manual, contact VMAC Technical Support prior to initiating or proceeding with installation, service or repair. Current information may clarify the issue. Anyone with knowledge of such discrepancies, who proceeds to perform service and repair, assumes all risks.

Only proven service procedures are recommended. Anyone who departs from the specific instructions provided in this manual must first ensure that their safety and that of others is not being compromised, and that there will be no adverse effects on the operational safety or performance of the equipment.

VMAC will not be held responsible for any liability, consequential damages, injuries, loss or damage to individuals or to equipment as a result of the failure of anyone to properly adhere to the procedures set out in this manual or standard safety practices.

Safety should be the first consideration when performing any service operations. If there are any questions concerning the procedures in this manual, or more information is required, please contact VMAC Technical Support prior to beginning work.

## Safety Messages

This manual contains various warnings, cautions and notices that must be observed to reduce the risk of personal injury during installation, service or repair and the possibility that improper installation, service or repair may damage the equipment or render it unsafe.



*This symbol is used to call attention to instructions concerning personal safety. Watch for this symbol; it points out important safety precautions, it means, "Attention, become alert! Your personal safety is involved". Read the message that follows and be aware of the possibility of personal injury or death. As it is impossible to warn of every conceivable hazard, common sense and industry standard safety practices must be observed.*



*This symbol is used to call attention to instructions on a specific procedure that if not followed may damage or reduce the useful life of the compressor or other equipment.*



*This symbol is used to call attention to additional instructions or special emphasis on a specific procedure.*

# Warranty

## VMAC Standard Warranty (Limited)

For complete warranty information, including both VMAC Standard Warranty (Limited) and VMAC Lifetime Warranty (Limited) requirements, please refer to our current published warranty located at: [www.vmacair.com/warranty](http://www.vmacair.com/warranty)



If you do not have access to a computer, please contact us and we will be happy to send you our warranty.

VMAC's warranty is subject to change without notice.

## VMAC Lifetime Warranty (Limited)

A VMAC Lifetime Limited Warranty is offered on the base air compressor only and only on UNDERHOOD, Hydraulic Driven, Transmission Mounted, Gas and Diesel Engine Driven Air Compressors, Multifunction Power Systems, and other products as defined by VMAC, provided that (i) the purchaser fully completes and submits a warranty registration form within 3 months of purchase, or 200 hours of operation, whichever occurs first; (ii) services are completed in accordance with the Owner's Manual; (iii) proof of purchase of applicable service kits are made available to VMAC upon request.



The VMAC Lifetime Warranty is applicable to new products shipped on or after 1 October, 2015.

## Warranty Registration

The VMAC warranty registration form is located near the back of this manual. This warranty registration form must be completed and sent to VMAC at the time of installation for any subsequent warranty claim to be considered valid.

There are 4 ways the warranty can be registered with VMAC:



[www.vmacair.com/warranty](http://www.vmacair.com/warranty)



[warranty@vmacair.com](mailto:warranty@vmacair.com)



(877) 740-3202



VMAC - Vehicle Mounted Air Compressors  
1333 Kipp Road, Nanaimo, BC, Canada V9X 1R3

# VMAC Warranty Claim Process



**VMAC warranty work must be pre-authorized by VMAC. Claims are processed via our dealer network. If you are not a VMAC dealer, please select one to work with via our Dealer Locator:**  
<https://www.vmacair.com/dealer-locator/>



1. Communicate with VMAC Technical Support at 1-888-241-2289 or [tech@vmacair.com](mailto:tech@vmacair.com) to help diagnose/troubleshoot the problem prior to repair. VMAC technical support will require the VMAC System ID, and hours on the compressor.
2. VMAC will provide direction for repair or replacement of the failed components.
3. If requested, failed parts must be returned to VMAC for evaluation.
4. Dealers may login to the VMAC website to view the "VMAC Labour Time Guide" (under "Agreements") to see the allowable warranty labour times.
5. Warranty invoices must include the Service Ticket number, VMAC System ID#, hours on the compressor, and a detailed description of the work performed.
6. VMAC Warranty does not cover consequential damages, overtime charges, mileage, travel time, towing/recovery, cleaning or shop supplies.
7. Dealers submit warranty claims on behalf of the Vehicle Owner/End User affected by the defective part(s). The dealer ensures that all warranty credits are refunded back to the Vehicle Owner/End User who made the initial warranty claim.



***In order to qualify for Lifetime Warranty (Limited), the completed warranty registration form must be received by VMAC within 3 months of the buyer receiving the Product(s), or 200 hours of operation, whichever occurs first.***

***If the completed warranty registration form has not been received by VMAC within 3 months of the buyer receiving the Product(s), or 200 hours of operation, the warranty period will be deemed to commence 30 days from the date of shipment from VMAC.***

***Failure to follow the warranty claim process may result in denial of the warranty claim.***

VMAC Product Warranty Policies & Warranty Registration can be found on the VMAC website (see previous page for URL).

# General Information

## Optional Equipment Compatibility

While VMAC strives to design systems compatible with optional OEM equipment (such as running boards), it is impractical to develop systems that accommodate every OEM and aftermarket option or add-on. Whenever possible, VMAC endeavors to advise of compatibility issues in the "Additional Application Information" section of the manual. Even when specific optional equipment is determined by VMAC to be incompatible, it does not preclude the vehicle upfitter or end user from modifying the optional equipment to make it compatible with the installed VMAC system. VMAC does not warranty or accept responsibility or liability for the fitment, function or safety of any products modified in any way not expressly outlined in the installation manual.

## Before Starting



**Note and label all parts that are removed from the vehicle as many of the OEM parts will be reused during the installation of the VMAC system.**

Read this manual prior to beginning the installation to ensure familiarity with the components and how they will fit on the vehicle. Identify any variations from the application list such as vehicle model, engines, or optional equipment (e.g., dual alternator, active steering assist, etc.).

Open the package, unpack the components and identify them using the Illustrated Parts List (IPL) included in the Fastener Pack.

## Hose Information

Depending on other installed equipment, it might be necessary to move the air/oil separation tank from its intended location. The hoses used in VMAC compressor systems have a specific inner liner that is compatible with VMAC compressor oil. Use of hoses other than those supplied or recommended by VMAC may cause compressor damage and may void your warranty. Please contact VMAC for replacement hoses and further information.

## Ordering Parts

To order parts, contact a VMAC dealer. The dealer will ask for the VMAC serial number, part number, description and quantity. Locate the nearest dealer online at [www.vmacair.com/dealer-locator](http://www.vmacair.com/dealer-locator) or call 1-877-912-6605.





## Special Tools Required

- 15 mm serpentine belt wrench.

## Torque Specifications

All fasteners must be torqued to specifications. Use manufacturers' torque values for OEM fasteners.

The torque values supplied in Table 1 are intended for VMAC supplied components, or for use as a guide in the absence of a torque value provided by an OEM.



**Apply Loctite 242 (blue) to all fasteners (except nylon lock nuts) unless otherwise stated.**

Torque values are with Loctite applied unless otherwise specified.

Standard Grade 8 National Coarse Thread								
Size (in)	1/4	5/16	3/8	7/16	1/2	9/16	5/8	3/4
Foot pounds (ft•lb)	9	18	35	55	80	110	170	280
Newton meter (N•m)	12	24	47	74	108	149	230	379

Standard Grade 8 National Fine Thread					
Size (in)	3/8	7/16	1/2	5/8	3/4
Foot pounds (ft•lb)	40	60	90	180	320
Newton meter (N•m)	54	81	122	244	434

Metric Class 10.9						
Size (mm)	M6	M8	M10	M12	M14	M16
Foot pounds (ft•lb)	4.5	19	41	69	104	174
Newton meter (N•m)	6	25	55	93	141	236

Table 1 — Torque Table

# Preparing for Installation



**Preparation for installation is very important. Missing a step or an item can cause problems in the installation or damage to components.**

**Check off each item as it is completed so that no steps are missed.**



**Apply Loctite 242 (blue) to all fasteners (except nylon lock nuts) unless otherwise stated.**

- Review the contents of the system using the illustrated parts list to ensure all components are present and in the correct quantity. If any components are missing, have the system ID ready and call VMAC Technical Support at (888) 241-2289.



**Dual alternator vehicles must be converted to single alternator prior to proceeding with the VMAC installation.**



**Prior to proceeding, ensure "Transport Mode" has been deactivated (contact a local Ford dealership or refer to the vehicle's owner's manual for instructions).**

- Move the driver seat completely to the rear and remove the (x2) front fasteners (Figure 1).



Figure 1 — Driver seat (front)

- Move the driver seat completely forward and remove the (x2) rear fasteners (Figure 2).

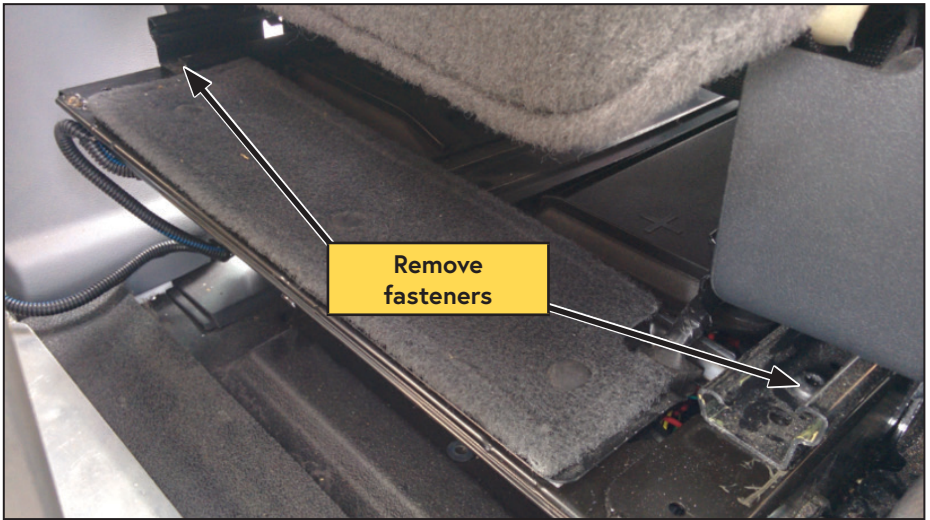

Figure 2 — Driver seat (rear)

- Remove the seat electrical connector (Figure 3).

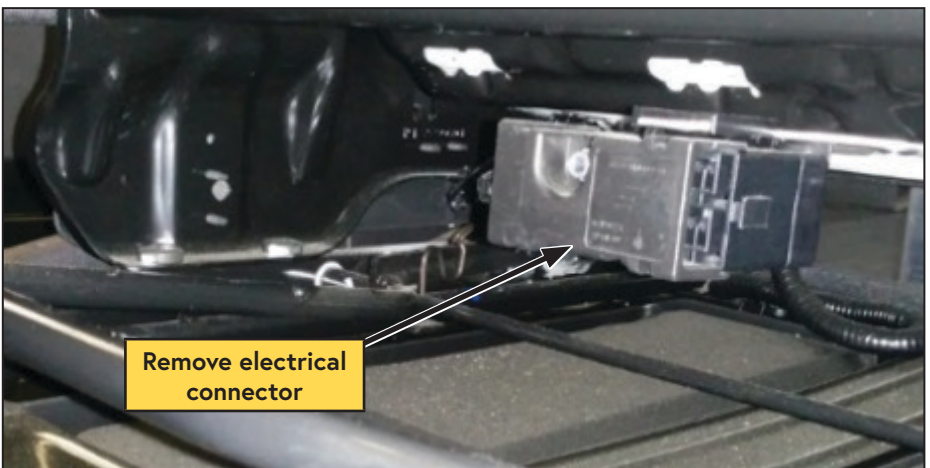

Figure 3 — Seat electrical connector

- The seat electrical harness is hooked to a stud on the bottom of the seat. Ensure the harness is unhooked and the wire can hang loose under the seat.
- Leave the seatbelt connected to the seat and lift the seat off of its mount; place the seat on the floor outside of the driver side of the van.



*The driver seat is heavy, use care when lifting it to prevent injury.*

- Remove the (x2) bolts underneath the piece of carpet at the rear of the battery cover retaining plate. Remove the metal bracket, then lift the plastic tabs on the rear of the battery cover to remove the battery cover (Figure 4).

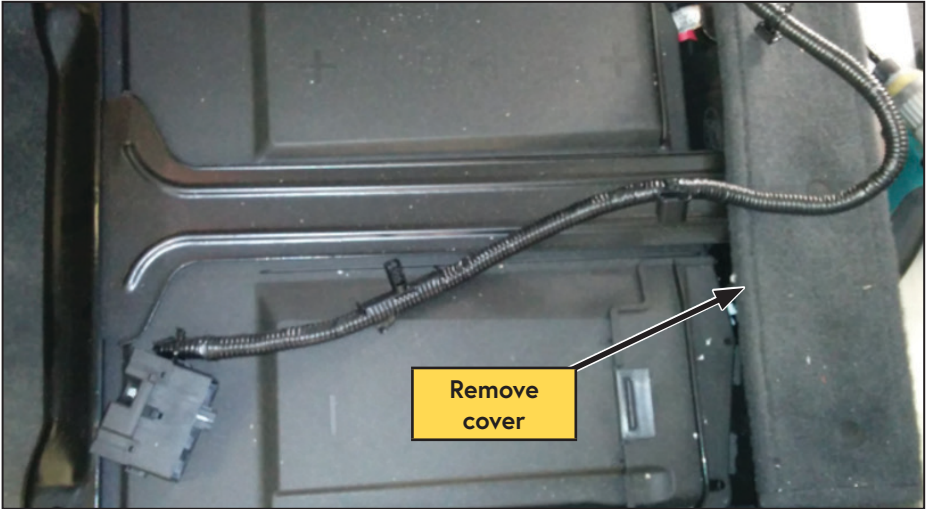

**Figure 4 — Battery cover**

- Disconnect the negative battery cable(s) from the battery terminal stud (Figure 5).

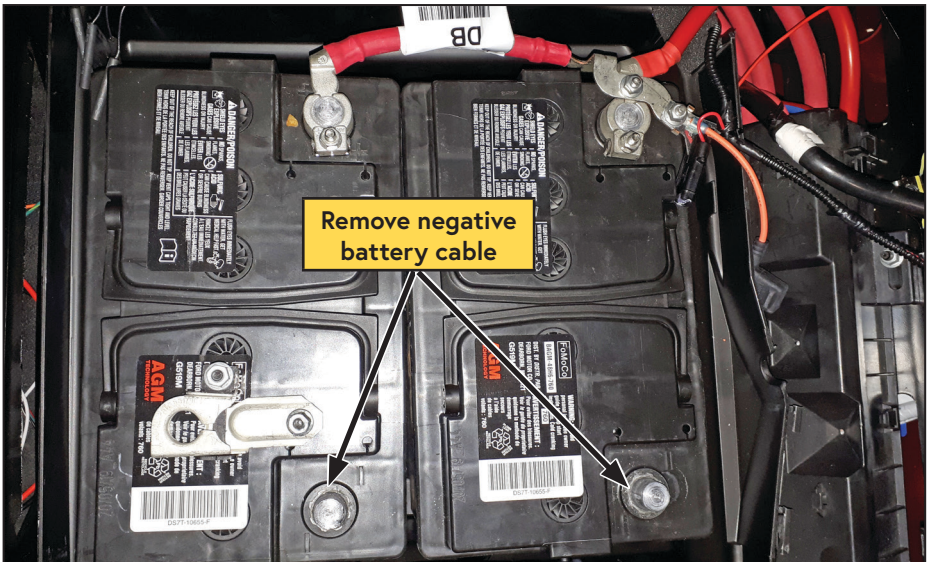

**Figure 5 — Battery cables**

- Remove the headlights and set them aside (this greatly improves access).
- From underneath the vehicle, use a 15 mm serpentine belt wrench to release the tension and remove the OEM 6 rib belt from the crank pulley. Tuck the belt out the way (Figure 6).

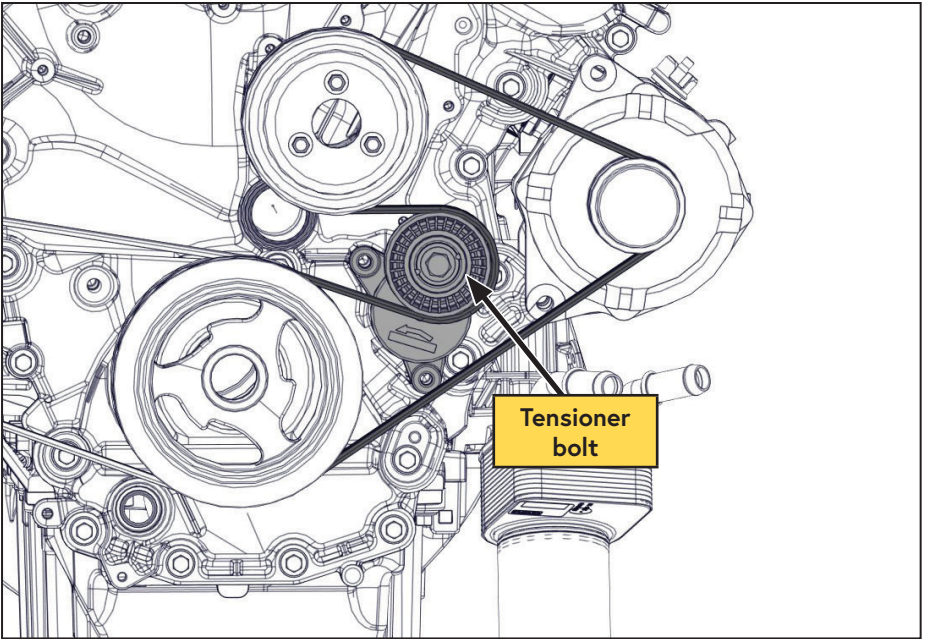

Figure 6 — Remove 6 rib belt

- Vehicles that have been converted to single alternator, skip this step:* Remove the stretch fit A/C compressor belt (Figure 7).

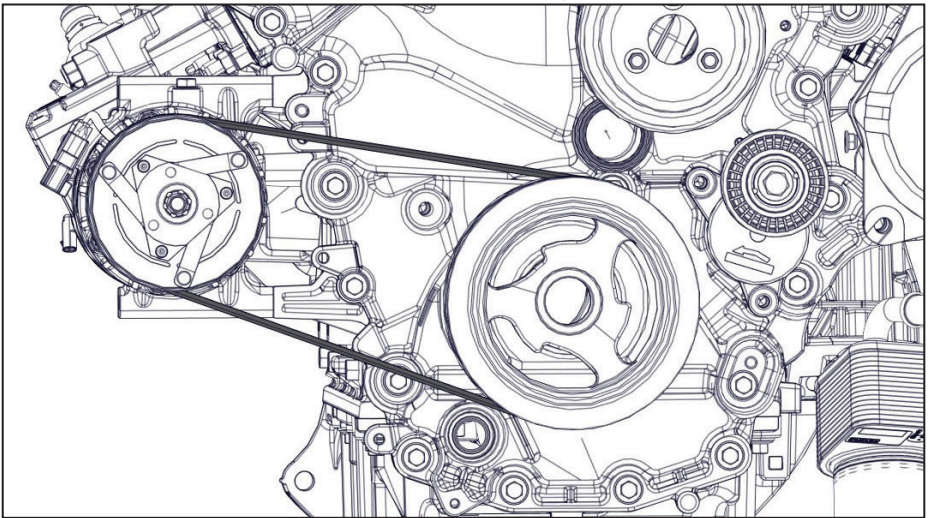
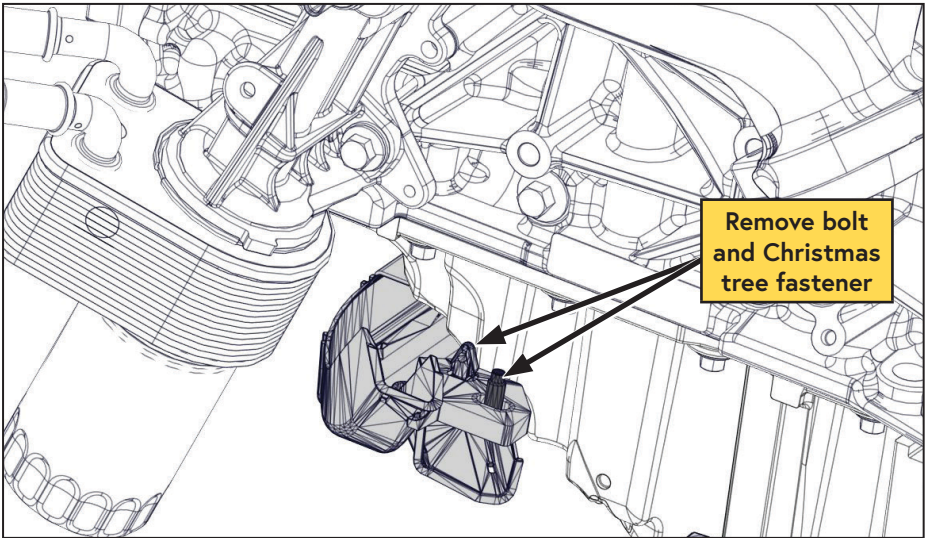

Figure 7 — Remove 4 rib belt

- Remove the bolt and Christmas tree fastener from the driver side cable tray and set them aside for later (Figure 8).



*Ecoboost engine shown, the Duratec engine will be similar.*



**Figure 8 — Remove cable tray**

- Remove and discard the stud securing the passenger side of the cable tray. Pull the tab off the mounting stud and push the wiring harness out of the way (Figure 9).

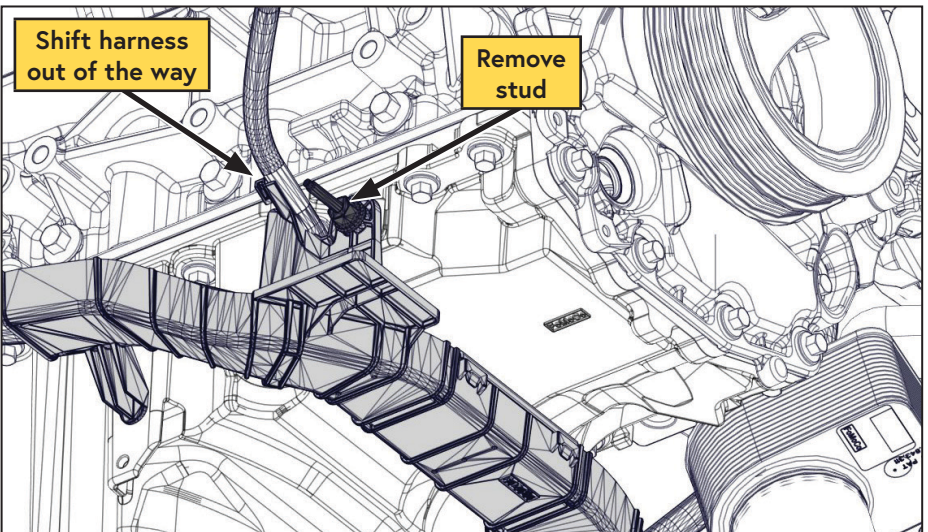

**Figure 9 — Remove cable tray**

- Remove and discard the timing cover bolts (Figure 10).

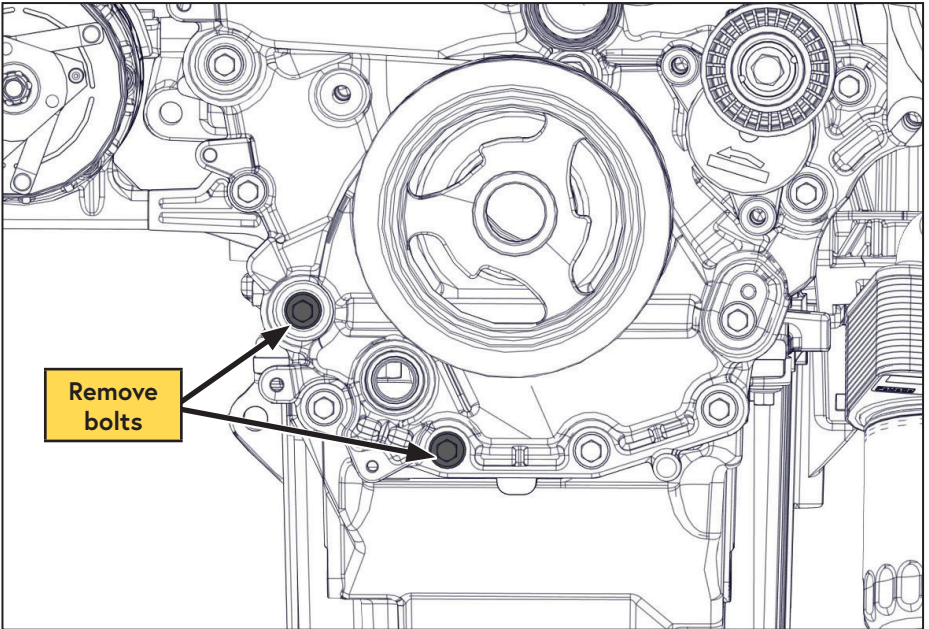

Figure 10 — Remove timing cover bolts



*Use caution when working around A/C system as excessive or repeated bending of the A/C lines can cause them to weaken or rupture.*

*Exposure to refrigerant can cause serious injury or death.*

- Leaving the A/C lines connected, remove the A/C compressor and secure it up and out of the way (Figure 11).

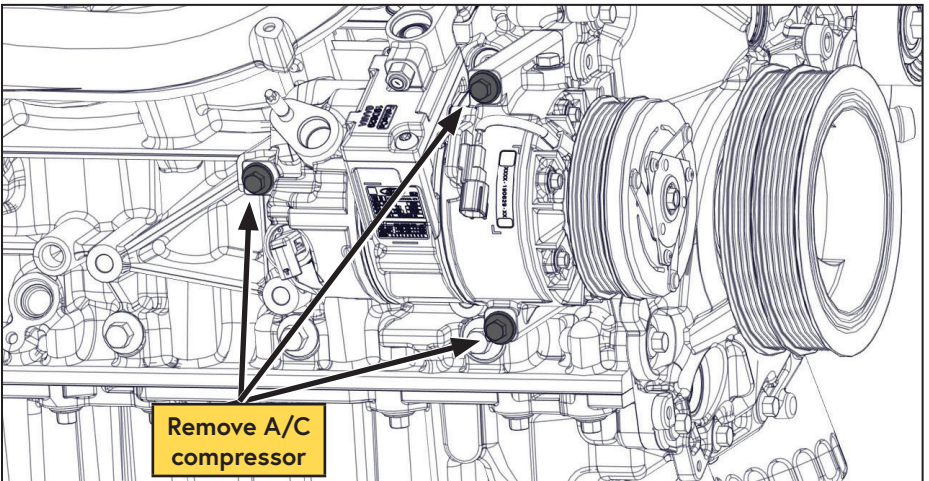

Figure 11 — Remove A/C compressor

# Installing the main bracket and Compressor

- Using the supplied fasteners, mount the main bracket onto the engine (Figure 12).

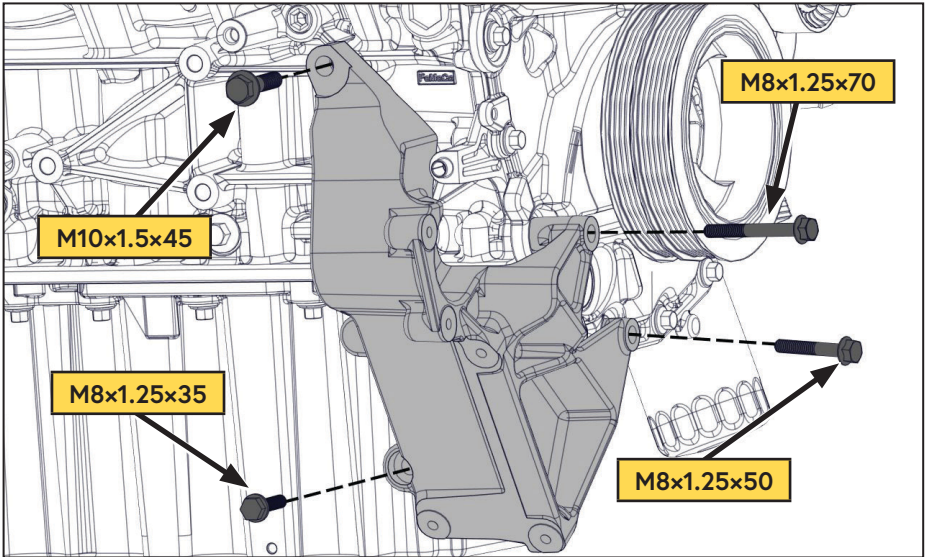

Figure 12 — Install main bracket

- Reinstall the A/C compressor onto the engine.
- Using (x2) M8 x 1.25 x 50 mm bolts, install the 4 rib belt tensioner onto the VMAC main bracket (Figure 13).

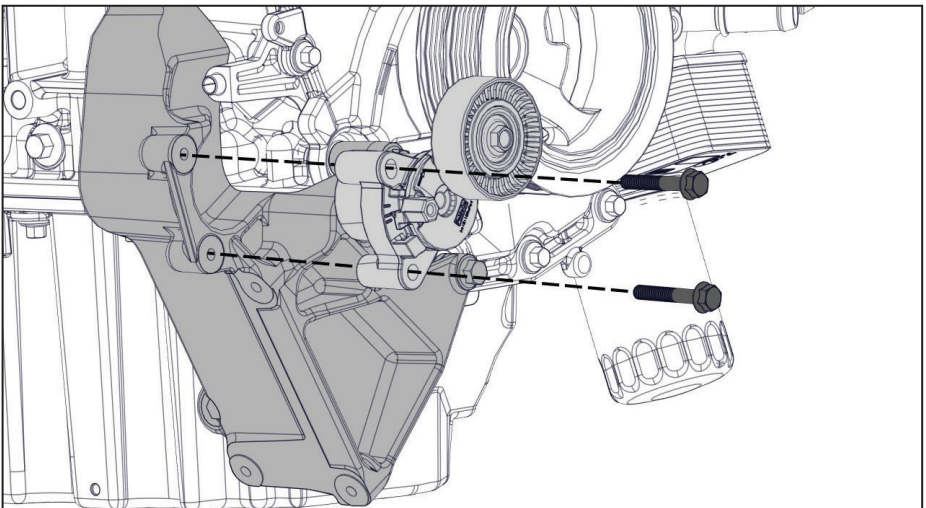

Figure 13 — Install tensioner



- Slide the pressure sensor assembly into the P-clip and mount it to the bracket using the supplied M6 × 1 × 14 mm bolt, and M6 nut (Figure 14).

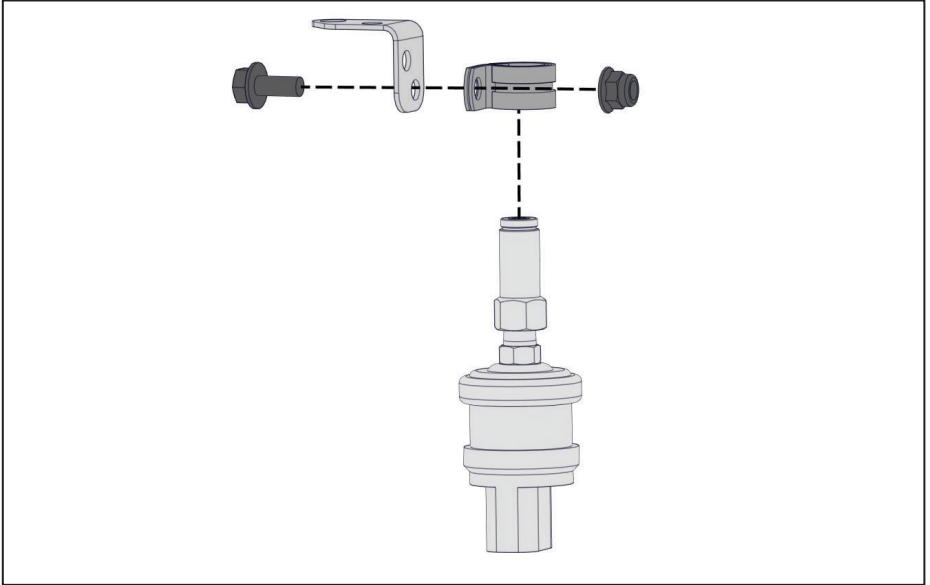

Figure 14 — Mount compressor

- Using the (×3) M8 × 1.25 × 35 mm bolts, mount the compressor assembly, and pressure switch assembly (in the orientation shown) onto the main bracket (Figure 15).

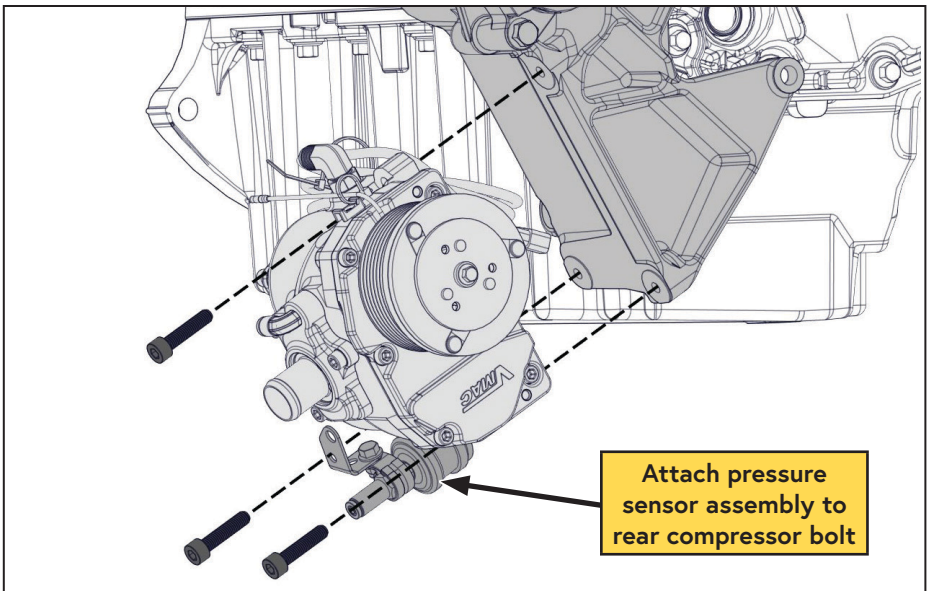

Figure 15 — Mount compressor

- Install and tension the supplied 4 rib VMAC Compressor belt, ensuring that it is centered on the compressor clutch (Figure 16).

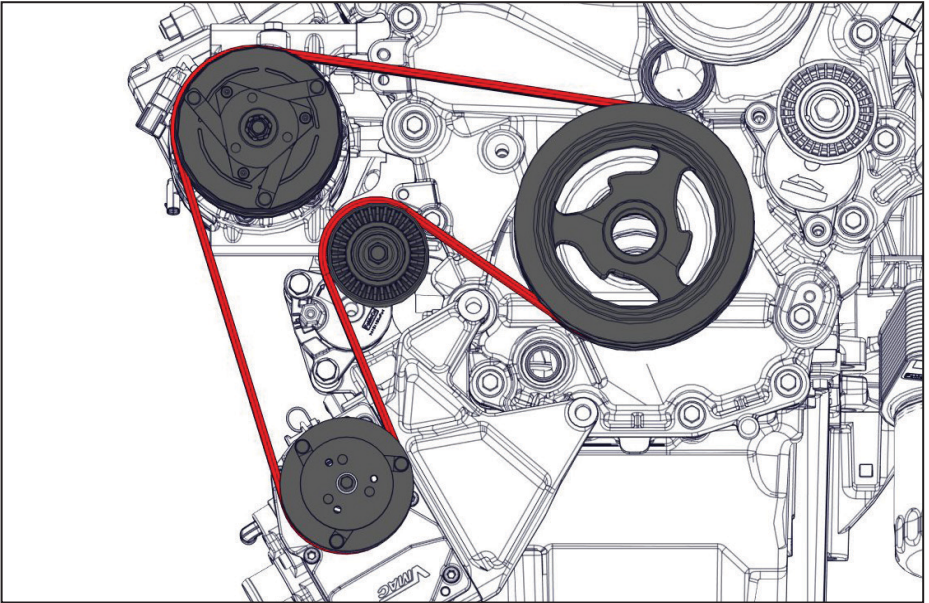

Figure 16 — Route VMAC belt

- Reinstall and tension the OEM 6 rib belt (Figure 17).

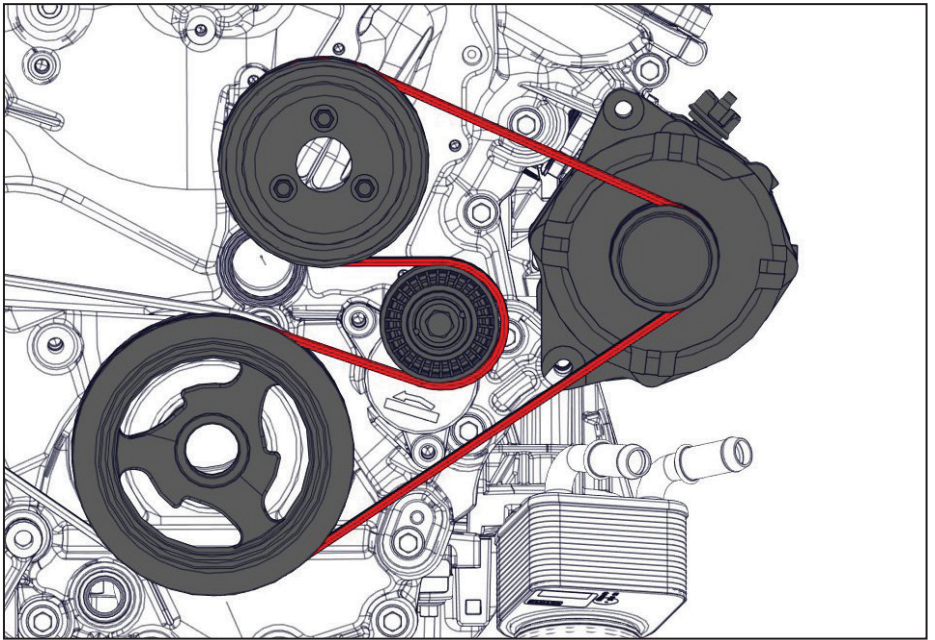

Figure 17 — 6 rib belt routing

# Installing the Waste Heat Air Separator Package (WHASP) Tank

## Tank location guidelines



*When determining a mounting location for the WHASP Tank, ensure the following conditions are met:*

- Adequate supply of fresh air and venting for the cooling fan.
- Minimum of 12 in of clearance at the front of the cooling fan.
- Minimum of 6 in clearance at the rear of the unit.
- Hose connections and wiring are accessible.
- Mounted on a level surface.
- Impact protection.
- The oil level sight glass is easily accessible.
- The oil fill and drain ports are accessible for servicing.
- Minimize the hose lengths to maximize performance.

## Mounting the WHASP Tank

Refer to (Figure 18) for mounting dimensions.

Special consideration must be made to ensure the WHASP Tank will be protected from damage and to ensure that it has adequate ventilation.

In some cases, it may be necessary to fabricate a mounting bracket to position the tank in an appropriate location.

Secure the WHASP Tank by bolting the mounting feet to the installation surface, use M8 or 5/16 in fasteners (not supplied).

## Mounting in an Enclosure or Body

Mounting the WHASP Tank in an enclosure will limit access to cooling air or restrict the escape of hot air from around the unit and will have an adverse effect on cooling.

Ensure adequate ventilation is provided for the cooling system to function properly.

It is not possible to make absolute recommendations regarding ventilation because of the widely differing configurations that are possible. Duty cycle, ambient temperature and enclosure shape are some of the important variables that need to be taken into account when determining the suitability of enclosure mounting.

Cool air ducted to the cooler and installing an exhaust fan to remove hot air is recommended.



*Confirm the hose lengths included in this kit when determining the location of the WHASP Tank and bulkhead fittings. Hose lengths can be found on page 23 or in the IPL. If the WHASP Tank or bulkhead fitting location requires longer hoses, contact a local VMAC dealer. See page 6 for ordering information.*

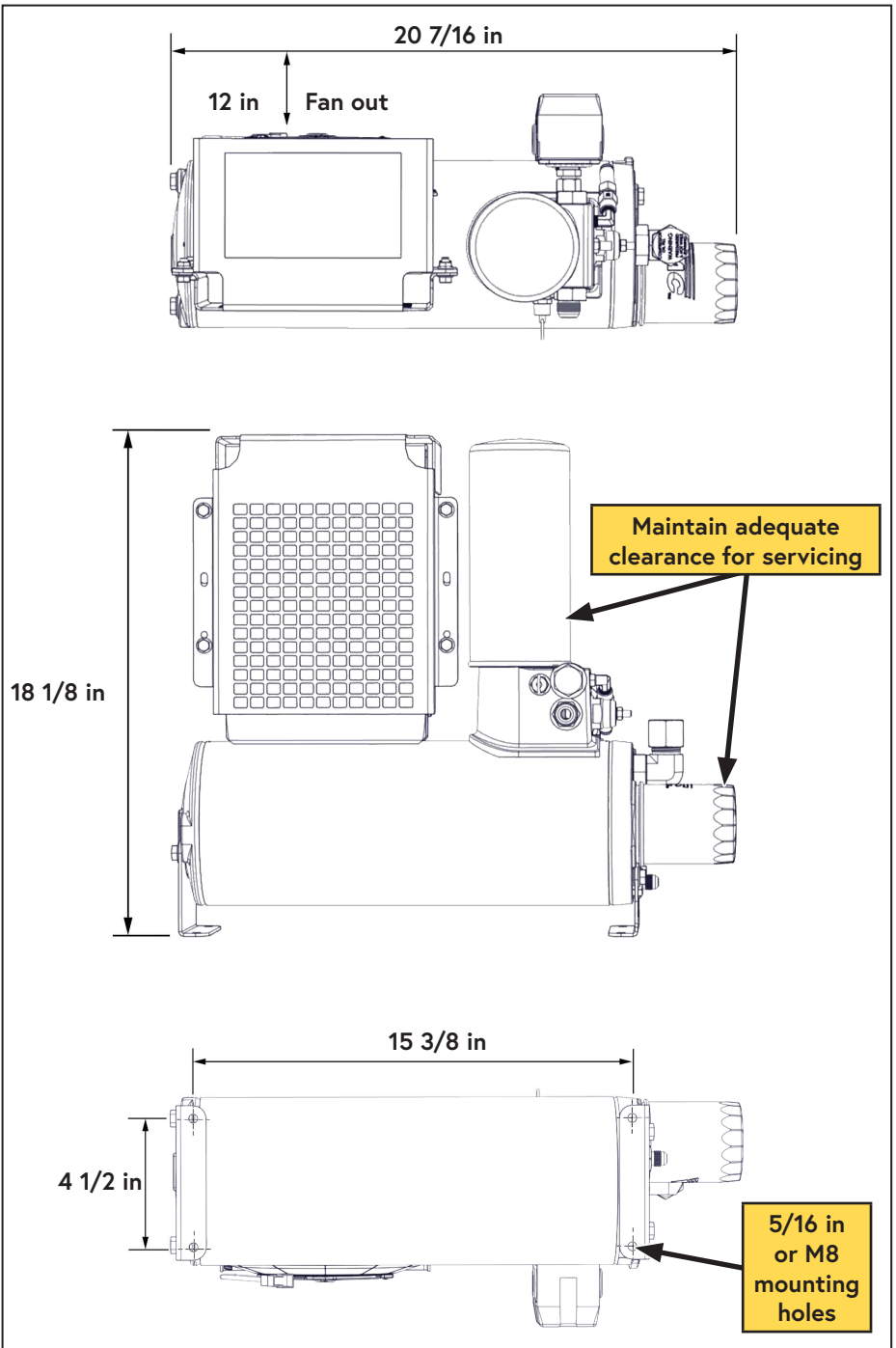

Figure 18 — Minimum WHASP Tank mounting clearances

## Mounting the WHASP Tank

The WHASP Tank uses a "puller" fan to cool the air/oil mixture. Position the WHASP Tank to ensure there is adequate air flow and so that the fan is blowing out toward the cargo door. During operation, the door should be kept open to ensure there is a constant supply of cool air to prevent the system from overheating (Figure 19).



*Provide ample space to check the oil level, as well as access to the filters and compressor oil drain to facilitate servicing.*

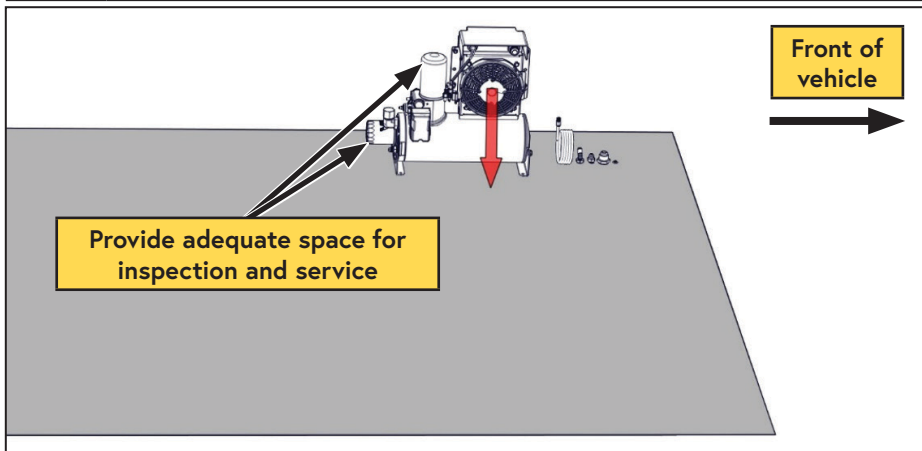

Figure 19 — WHASP ventilation



*A minimum of 6 in of clearance is recommended around the radiator (intake) side of the WHASP Tank to allow fresh, cool air to circulate into the cooler and fan (Figure 20).*

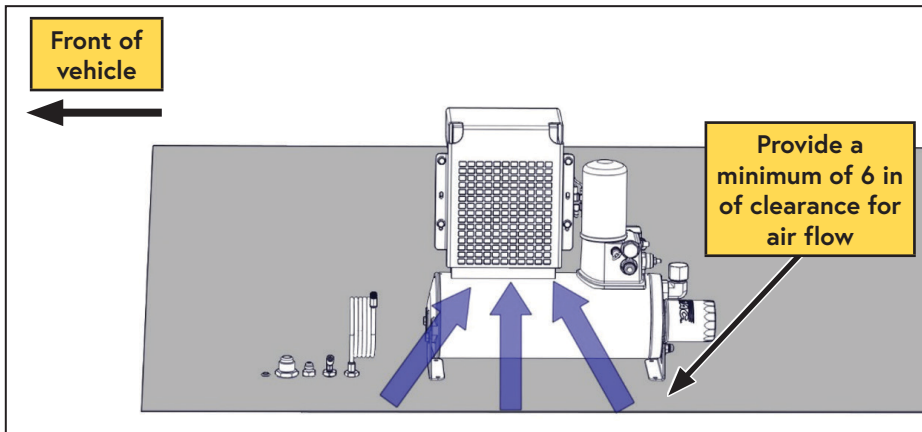

Figure 20 — WHASP ventilation

## Installing the Bulkhead Fittings

(×4) bulkhead fittings are supplied with the system (Figure 21):

- 3 bulkhead fittings are used to pass the system discharge, oil, and scavenge hoses/tubes into the body of the vehicle.
- 1 bulkhead fitting is used to locate the blowdown muffler outside of the vehicle.

This kit includes hoses of a fixed length to run from the compressor to the bulkhead fittings, and from the fittings to the WHASP Tank.

To maximize compressor performance, hose lengths should be kept as short as possible; if longer hoses are required please follow the hose requirements listed on page 23 of this manual.

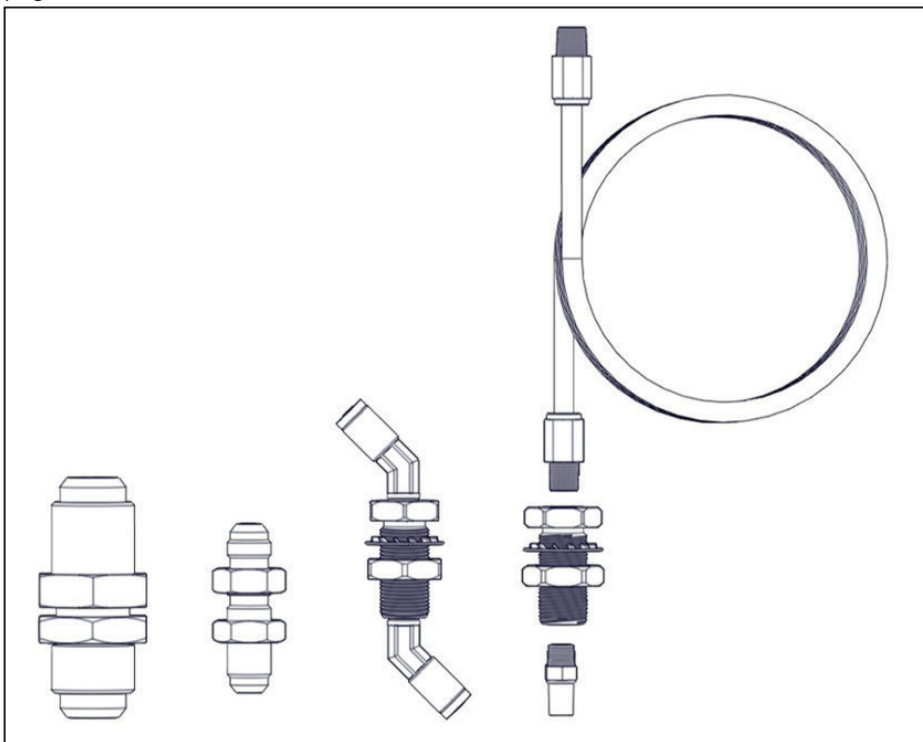

Figure 21 — Bulkhead fittings



*This kit includes hose lengths suitable for mounting the WHASP Tank directly behind the driver compartment bulkhead.*

*If not mounting in the standard location, VMAC recommends locating the WHASP tank as close to the compressor as is feasible (refer to "WHASP Tank location guidelines" on page 20).*

- Drill the bulkhead fitting holes using a drill, step drill or hole saw. Leave enough room between the fittings to allow access for a wrench (Figure 22, Figure 23, Figure 24):
- Discharge from the compressor:  $\varnothing 1\ 1/8$  in.
  - Oil return:  $\varnothing 9/16$  in.
  - Oil scavenge:  $\varnothing 5/8$  in.
  - Remote blowdown:  $\varnothing 5/8$  in.

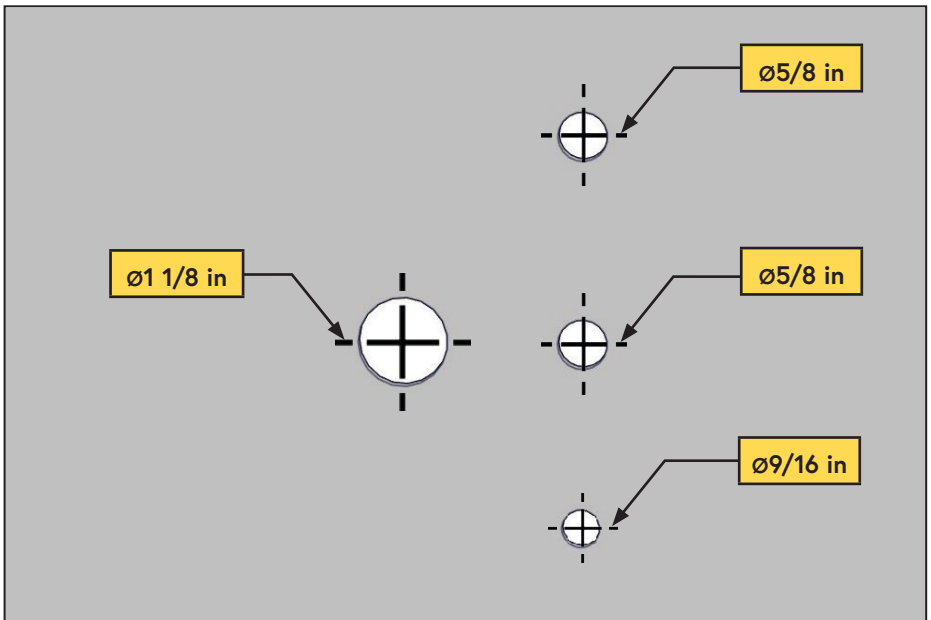

Figure 22 — Hole diameter

- Fit the bulkhead fittings through the top of the hole and secure from the bottom with the supplied nuts. Apply Loctite 567 (thread sealant) when installing the 1/4 in push-to-connect fittings in the bulkhead fittings (Figure 23, Figure 24).

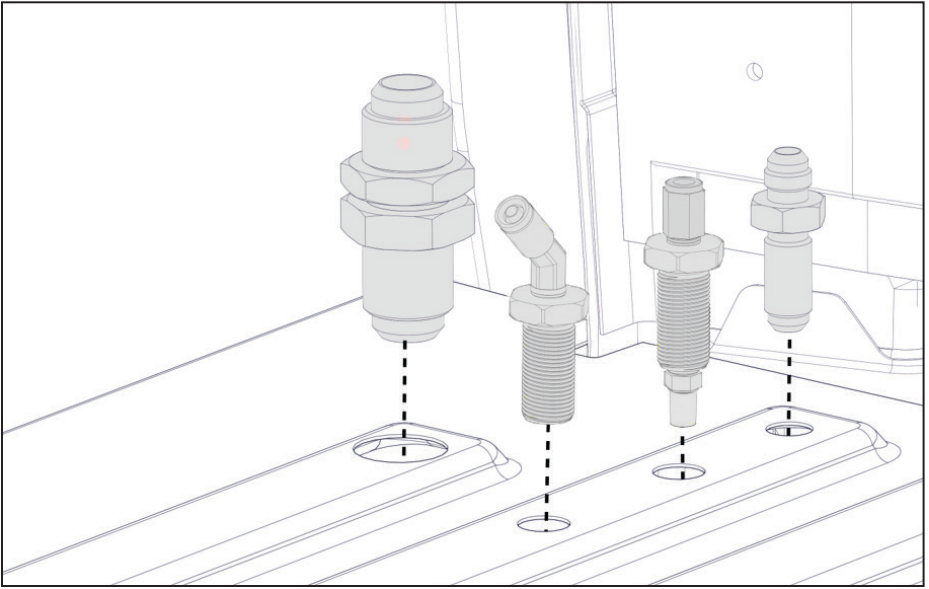

Figure 23 — Interior View

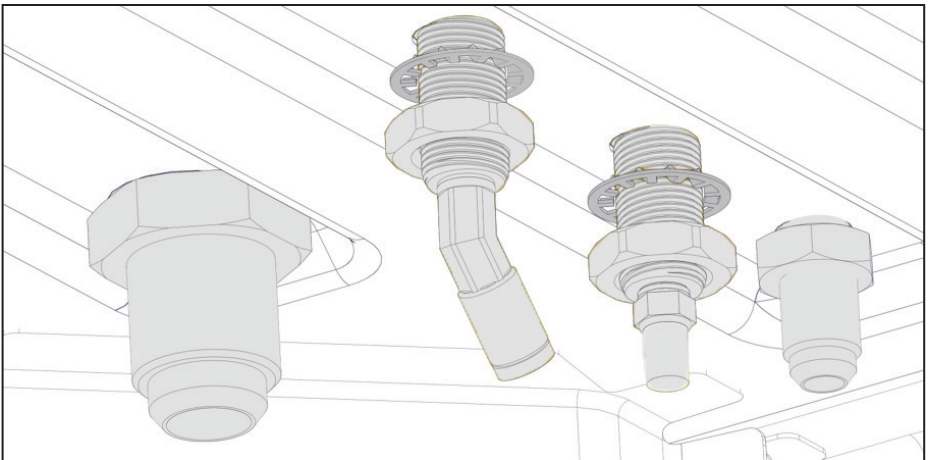

Figure 24 — Exterior View



# Hose Requirements



*Only attempt to shorten the supplied hose if there is access to the appropriate equipment. **Do not** attempt to cut the hose and splice it using hose clamps.*



*VMAC Compressor oil will degrade rubber lined hoses, use only hoses with an AQP elastomer type liner. Contact VMAC Technical Support at 1-888-241-2289 for further information.*

The 1/4 in PTFE tube, and the 3/8 in and 3/4 in hoses with AQP elastomer liner, are specifically designed to work with VMAC compressor oil and at compressor operating temperatures.

Based on the desired location of the WHASP Tank, the hose lengths provided with this system may not be ideal. They can be shortened or replaced as necessary, or hose extenders can be used.

VMAC recommends shortening these hoses as a preferred alternative to coiling up and securing the excess. **Shorter hose length will maximize system performance.**



*Avoid using 90° fittings wherever possible as they cause flow restrictions and negatively impact performance.*

The following hoses are included with this compressor kit:

## **From the compressor to the bulkhead fittings:**

- 3/4 in × 120 in.
- 3/8 in × 120 in.
- 1/4 in (PTFE Tube) × 125 in.

## **From the WHASP Tank to the bulkhead fittings:**

- 3/4 in × 96 in.
- 3/8 in × 84 in.
- 1/4 in (PTFE Tube) × 108 in.

## **If longer hoses are required:**

To order parts, contact a VMAC dealer. The dealer will ask for the VMAC serial number, part number, description and quantity. See page 6 for ordering information.

- Eaton Aeroquip hoses with an "AQP" type inner liner are required.
- OTC fittings are required for the VMAC supplied hose.
- Push-lock fittings are suitable if FC332 hose is used.
- If Push-lock fittings are being used, do not use hose clamps as they will damage the hose and cause leaks.

# Connecting the Hoses



*When routing hoses, ensure cap plugs are installed so that contaminants do not get in the line. Take care when routing hoses, as a hose failure may damage the compressor and/or cause injury.*



*All hoses, tubes and wires that are installed, rerouted or shifted during the installation must be secured so that they do not contact any hot, sharp or moving parts. Use rubber coated P-clips wherever possible. Follow the routing suggestions in this manual and cover all hoses with plastic loom.*



*Ensure there is sufficient slack in the hose routing to allow for normal engine movement.*

## PTFE Tubing, Loom, and Push-To-Connect Fittings

- PTFE tubing should only be cut using proper tubing cutters. Side cutters, utility knives, etc. will deform the tube, preventing a proper seal (or leave sharp edges which cut the internal O-ring).
- When applying loom to the PTFE tube, leave approximately 1 in between the loom and the fitting.
- Ensure the tube is clean, cut at 90° and that there are not sharp edges.
- Lubricate the tube and firmly push it into the fitting so that the tube fully seats in the fitting.
- Slide the collet out, away from the body of the fitting to lock the tubing in place.
- Ensure the tube does not have any "play" to prevent the O-ring from wearing.

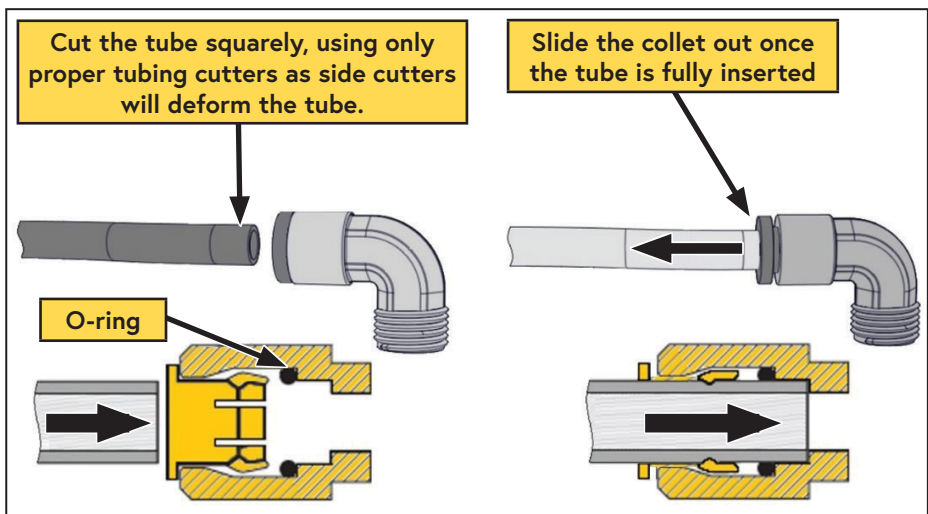

Figure 25 — Push-to-connect fittings

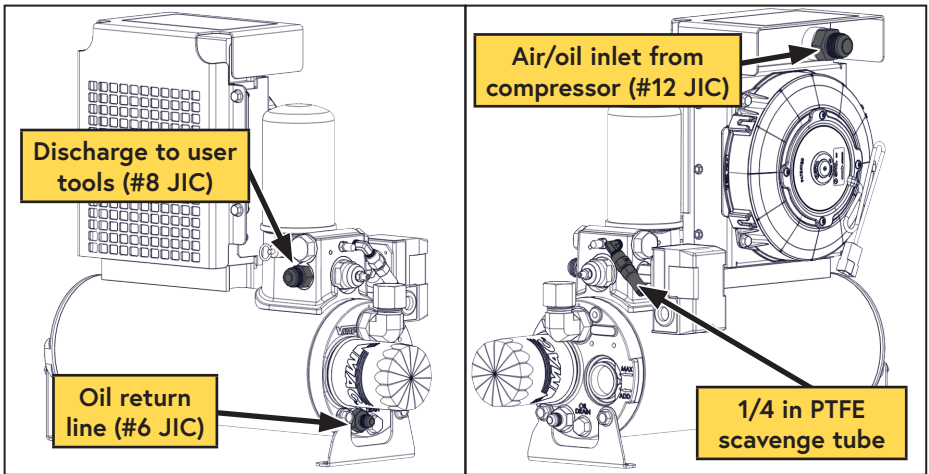

Figure 26 — WHASP Tank connections



*Use of an air receiver tank (minimum 6 USG) is required with this application.*

*Follow the instructions on page 51 of this manual to prevent damage to the system.*

## Remote Muffler Installation

The WHASP Tank automatically depressurizes when the clutch disengages. This prevents damage to the compressor on the next start up.

Installing the blowdown muffler outside of the vehicle will reduce cabin noise during blowdown, and will ensure any oil vapor will be safely discharged outside of the vehicle.

- Remove the blowdown muffler from the side of the WHASP Tank (below the coalescing filter) (Figure 27).

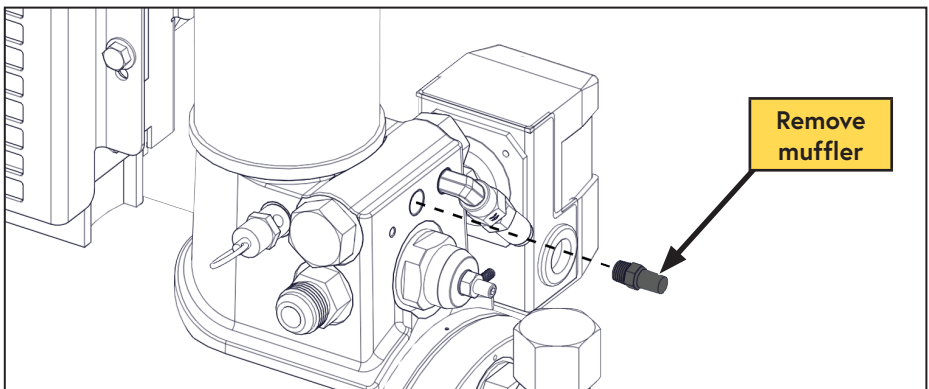
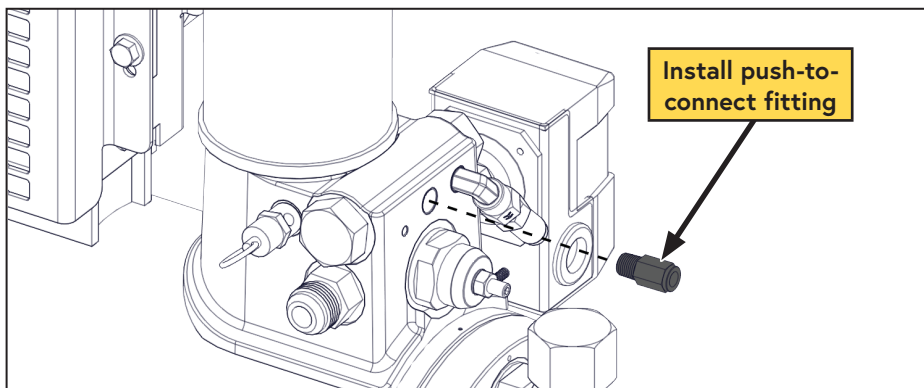

Figure 27 — Remove blowdown muffler



**Ensure no debris enters the WHASP Tank manifold. Contamination of the assembly may cause erratic performance.**

- Separate the PTFE tube from the fittings.
- Apply the supplied 1/4 in split loom to the 1/4 in PTFE tube.
- Apply Loctite 567 (thread sealing) compound to the 1/4 in push-to-connect fitting and install it into the threaded hole which previously held the blowdown muffler (Figure 28).



**Figure 28 — Install push-to-connect fitting**

- Connect the 1/4 in PTFE tube into the push-to-connect fitting installed in the WHASP Tank (Figure 29).

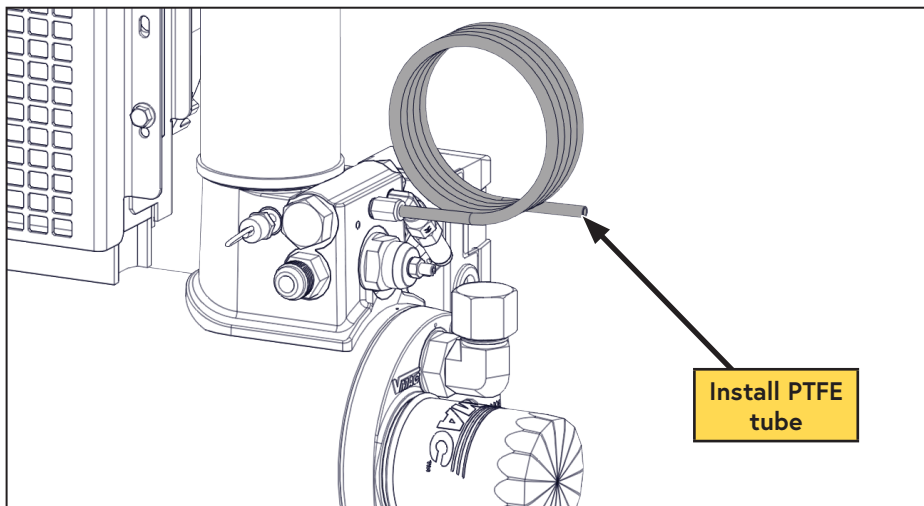

**Figure 29 — Tubing Installation**

- Route the 1/4 in PTFE tube to the bulkhead fitting, ensuring the tube will not kink, and cut the hose to length.



*Ensure the tube is cut square and that there are no sharp edges. Do not use side cutters as this will deform the hose.*

- Install the tube into the push-to-connect bulkhead fitting (Figure 30)

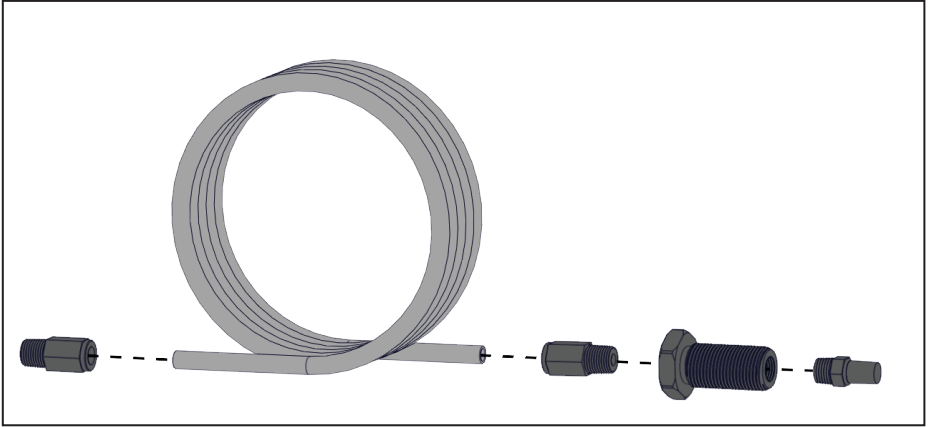

Figure 30 — Tubing Installation Remote Blowdown Muffler assembly

- Secure the tube with the supplied cable ties.

## Connecting the Exterior Hoses

- Install the curved end of the 1 in intake hose assembly onto the spigot on the side of the compressor. Direct the hose upwards and secure it using the supplied hose clamp (Figure 31).

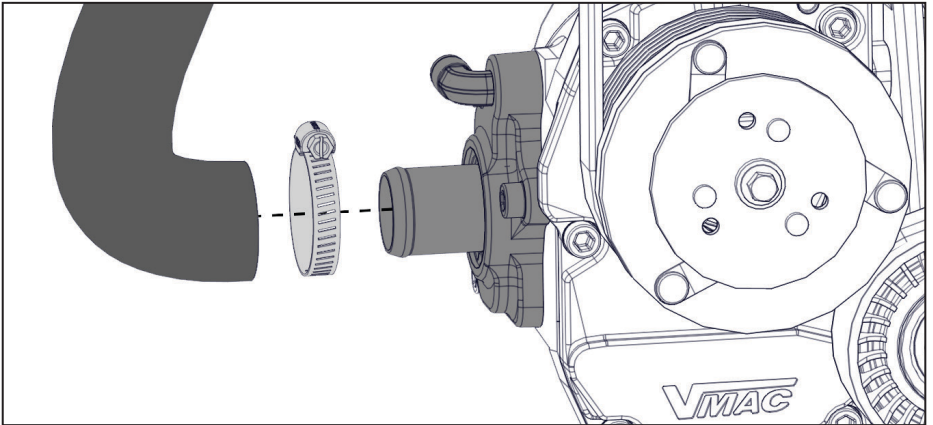

Figure 31 — Install intake hose

- Apply split loom, or equivalent hose protection (not supplied), to the 3/4 in x 120 in and 3/8 in x 120 in hoses.



**Ensure the distance between the pressure switch and the Union Tee is no more than 24 in, and the distance between the compressor and the Union Tee is no more than 6 in.**

- From the 24 in spool of 1/4 in PTFE tubing, connect the scavenge tube to the compressor, pressure switch assembly, and Union Tee (Figure 32).

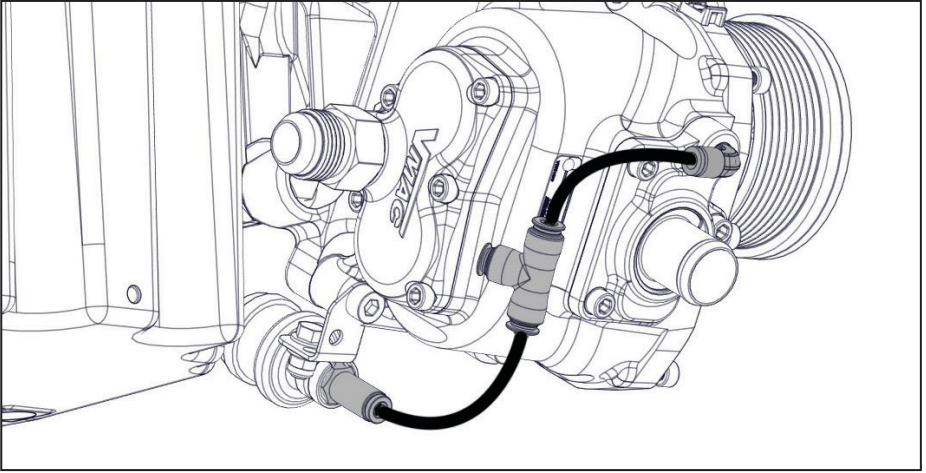

**Figure 32 — Connect PTFE tubes**

- Connect the 125 in PTFE tube to the Union Tee.
- Connect one end of the 3/4 in hose to the compressor discharge fitting on the rear of the compressor. Direct the hose toward the rear of the vehicle, between the engine and the crossmember (Figure 33).

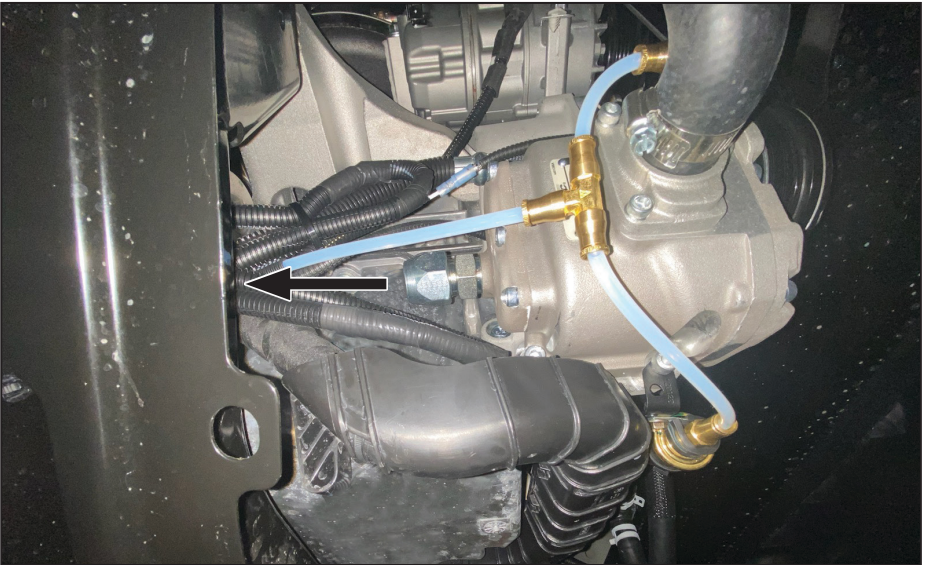

**Figure 33 — Install 3/4 in hose**

- Apply the supplied split loom to the 1/4 in PTFE tubes.
- Route the 3/8 in and 3/4 in hoses, together with the 1/4 in PTFE tube back along the engine, toward the transmission.
- Route the hose bundle under the rear of the engine towards the driver side of the vehicle (Figure 34).



**Figure 34 — Route hoses under the oil pan**

- Route the hoses along the inside of the driver side frame rail and secure them using the 2 supplied P-clips and 5/16 in x 3/4 in sheet metal screws in the existing holes on the frame (Figure 35).

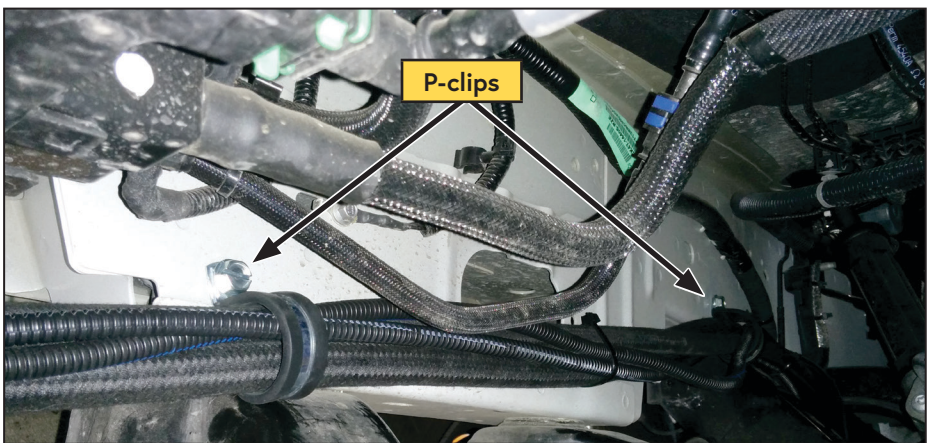

**Figure 35 — Hose routing along inside of driver side frame**

- Route the hoses above the fuel filler hose and toward the rear of the fuel filler housing (Figure 36, Figure 37).



**Figure 36 — Hose routing continued**

- Secure the hose using the supplied P-clip and 5/16 in x 3/4 in sheet metal screw, in the location shown (Figure 37).

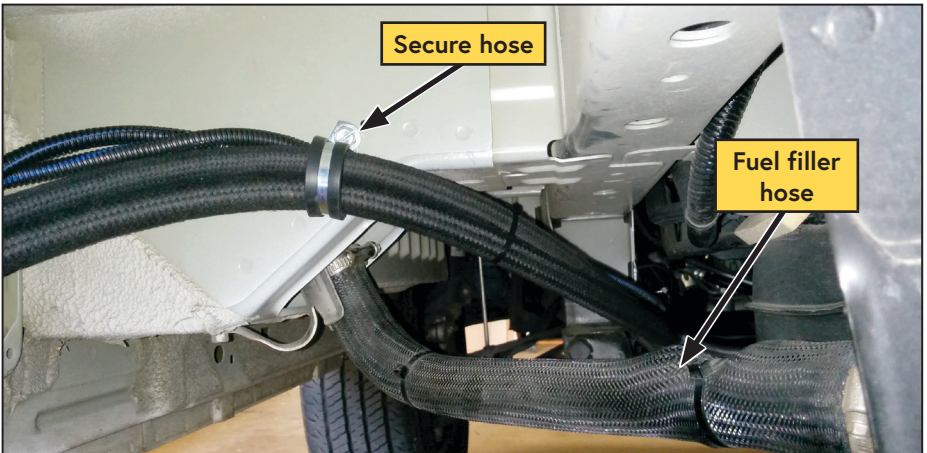

**Figure 37 — Hose routing above fuel filler hose**

- Attach the 3/4 in x 120 in, 3/8 in x 120 in hoses and the 1/4 in x 125 in PTFE tube to the underside of the bulkhead fittings. Ensure all of the fittings are fully seated, tight and secure.
- Ensure all of the hoses are routed away from any hot, sharp or moving parts, hydraulic lines, and vehicle wiring. Use cable ties, rubber coated P-clips, and suitable hose protection as required. If the vehicle is 4WD, ensure the hoses are protected from the front driveshaft.



# Adding Oil to the System



*The VMAC supplied and approved compressor oil must be used in this system. Failure to use this special oil will result in damage to the compressor and will void warranty.*

*Do not overfill the system. Overfilling the system with oil can flood the sight glass window and make the system appear empty.*

- Remove the fill cap on the WHASP Tank (above the sight glass) (Figure 38).
- Using a funnel, pour oil into the tank until the oil level in the sight glass reaches the "MAX" line. **The system capacity is 4 L** (Figure 38).
- Reinstall the fill cap and tighten it securely. Ensure the fill port remains accessible as it will be necessary to check and top up the oil after the first compressor start.

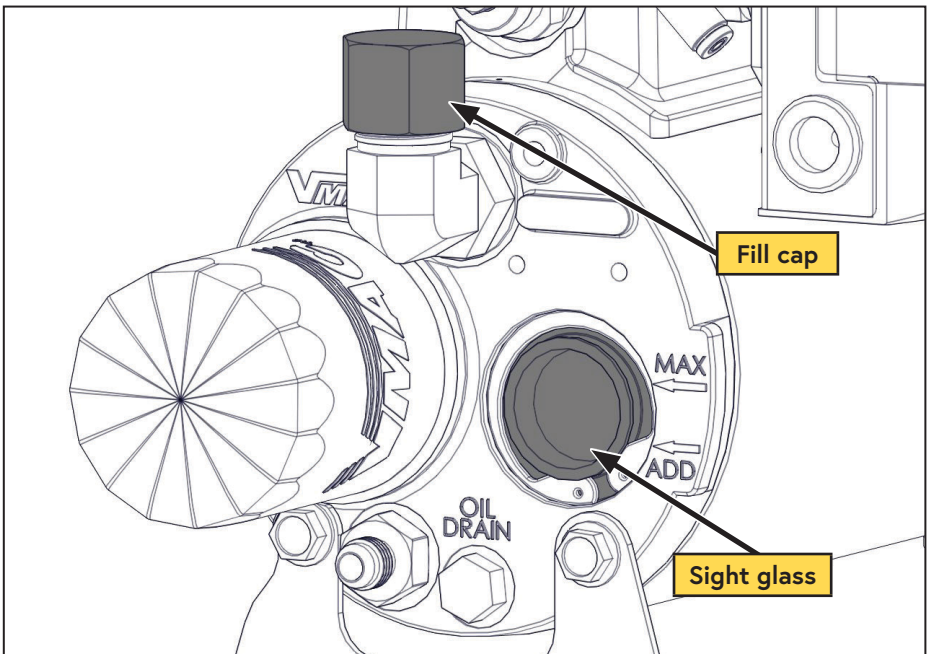

Figure 38 — Filling the WHASP Tank

# Installing the Control System

## Best Practices

- To confirm a good ground, use an ohm meter to measure the resistance between the ground point and the negative battery terminal. Resistance should be less than 1  $\Omega$ .
- Route all wires to ensure they will not contact hot, sharp or moving parts (including the park brake mechanism, steering column, and pedals).
- Before drilling any holes ensure there are no OEM wires, hoses, or components that may be damaged.
- Do not use a test light to probe for power on vehicle circuits, the increased current draw of the test light may damage components.
- VMAC recommends using only sealed crimp and solder butt connectors for all electrical connections.
- To ensure a durable connection, use only good quality crimping tools.
- Apply loom to all wiring:
  - Use high temperature loom in areas where high temperatures may be expected.
  - Use spiral loom in areas with high vibration.

## In-line Butt Splice Connections

- Cut the wire approximately 2 in from the connector.
- Strip approximately 3/8 in from the end of both sides of the cut wire, as well as from the end of the wire being spliced in-line.
- Twist the wire to be spliced in-line, together with the "live" side of the wire (not the wire attached to the connector).
- Slide the butt connector onto the twisted wires and crimp it.
- Insert the "connector side" of the wire into butt connector and crimp it.
- Lightly tug the wires to ensure they are properly crimped.
- Using a heat gun, carefully apply heat to the butt connectors to seal the connection.

## Electrical Modules

- The throttle control, control module, and interface panel are not weather proof; ensure they are mounted where they will be protected from rain, snow, mud, direct sunlight, etc. (e.g. inside the cab, service body or cabinet).
- Keep the rear of the interface panel protected.
- Ensure the control module and throttle control are mounted away from the pedals, park brake mechanism, or where they could be inadvertently knocked by occupants.

## Control Components Overview

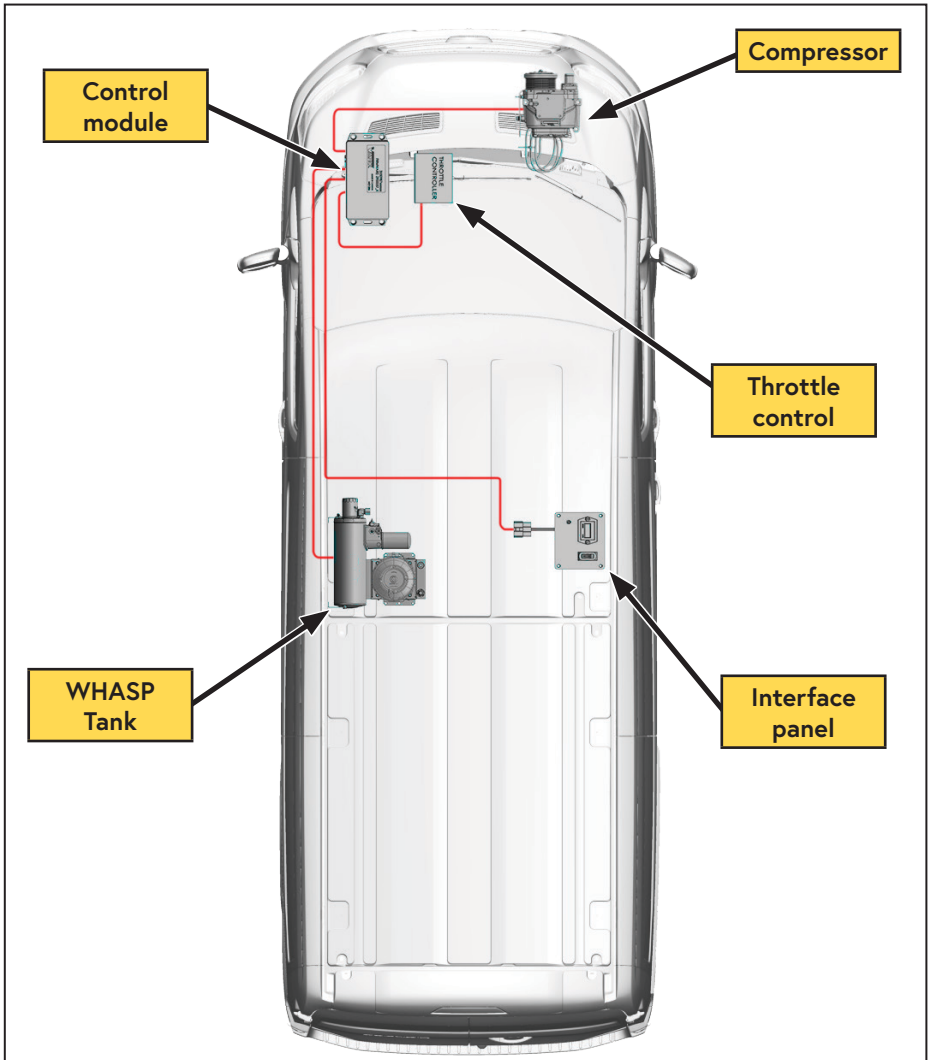

Figure 39 — General component overview  
(Actual installation locations may vary)

### Control Module (Figure 40)

The control module serves as the primary input/output interface between the vehicle and the various VMAC components (compressor, throttle control, WHASP Tank, Control Interface, etc.).

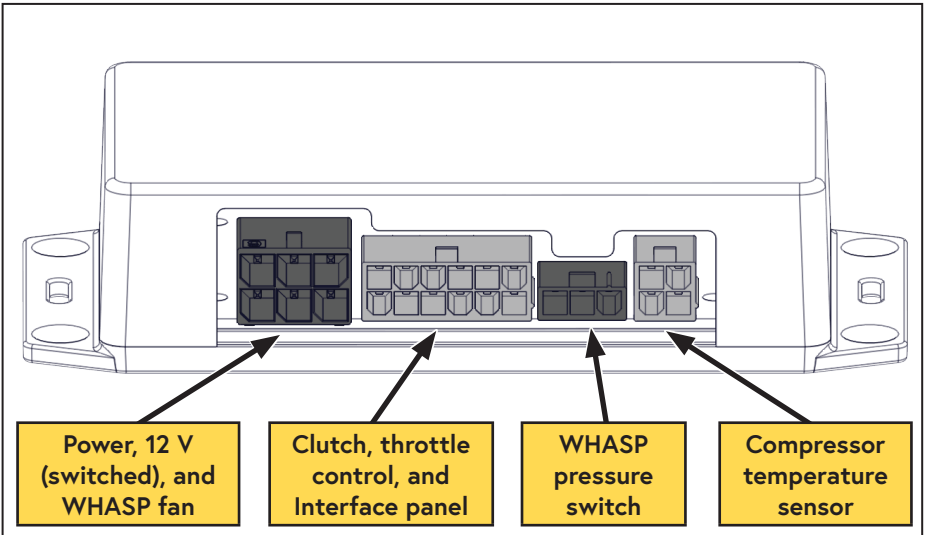

Figure 40 — Control module

### Interface Panel (Figure 41)

The interface panel serves as the operator's control panel and contains the "ON/OFF" switch, compressor status light, and the compressor hour meter.

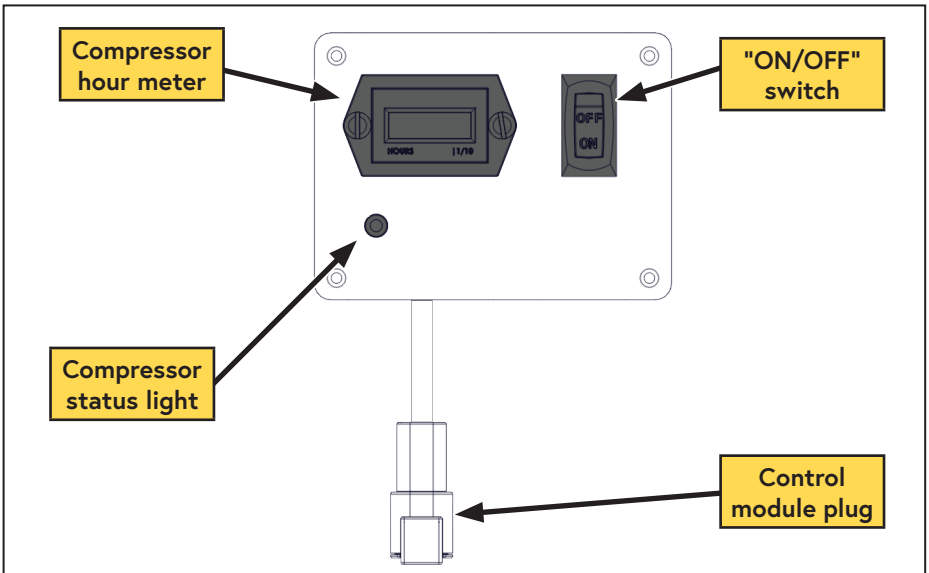

Figure 41 — Interface panel

### Throttle Control (Figure 42)

The throttle control responds to signals from the control module and commands the vehicle's throttle to increase or decrease engine speed in response to air demand. The throttle control also allows the operator to configure the vehicle's engine speed (when air is demanded) to their needs (maximum cfm, specific tool requirements, fuel efficiency, or a combination of these factors).

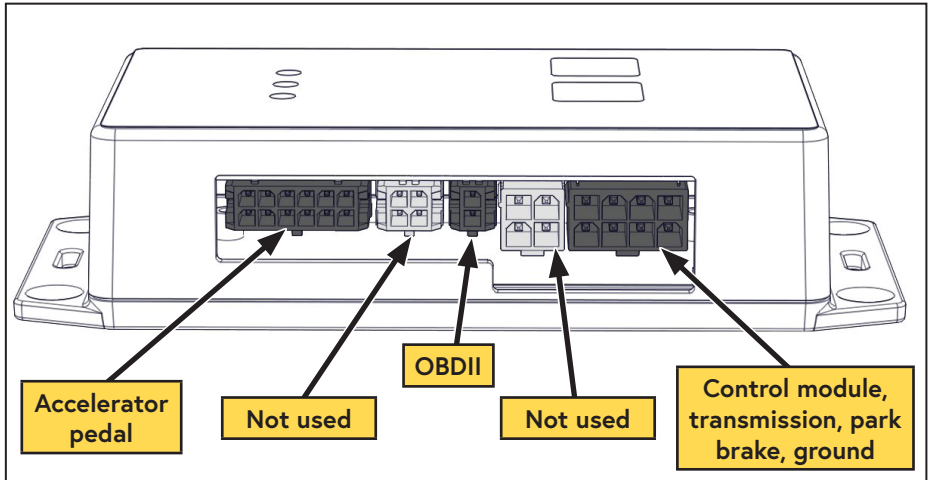

Figure 42 — VMAC digital throttle control

### Mechanical Pressure Switch (Figure 43)

The mechanical pressure switch is mounted on the side of the WHASP Tank and limits the maximum pressure to a safe amount by disengaging the clutch once system pressure is achieved.

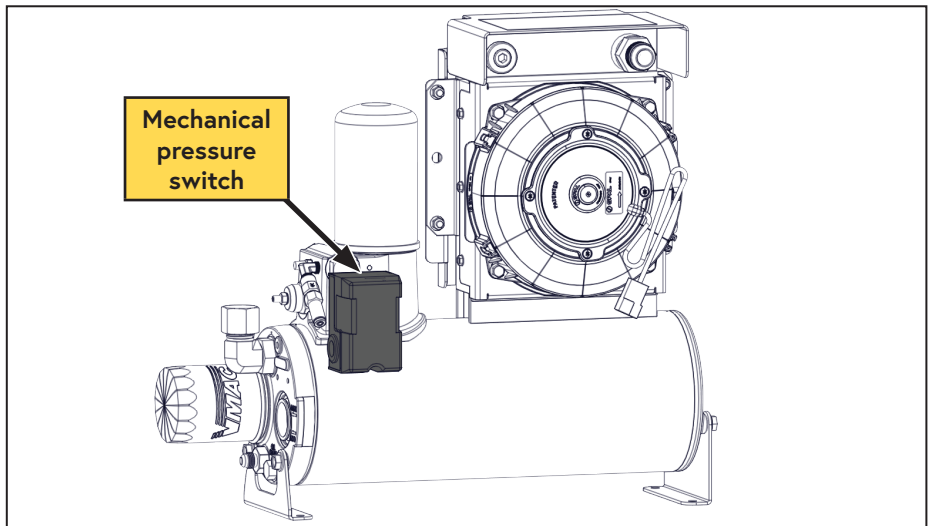

Figure 43 — WHASP Tank pressure switch

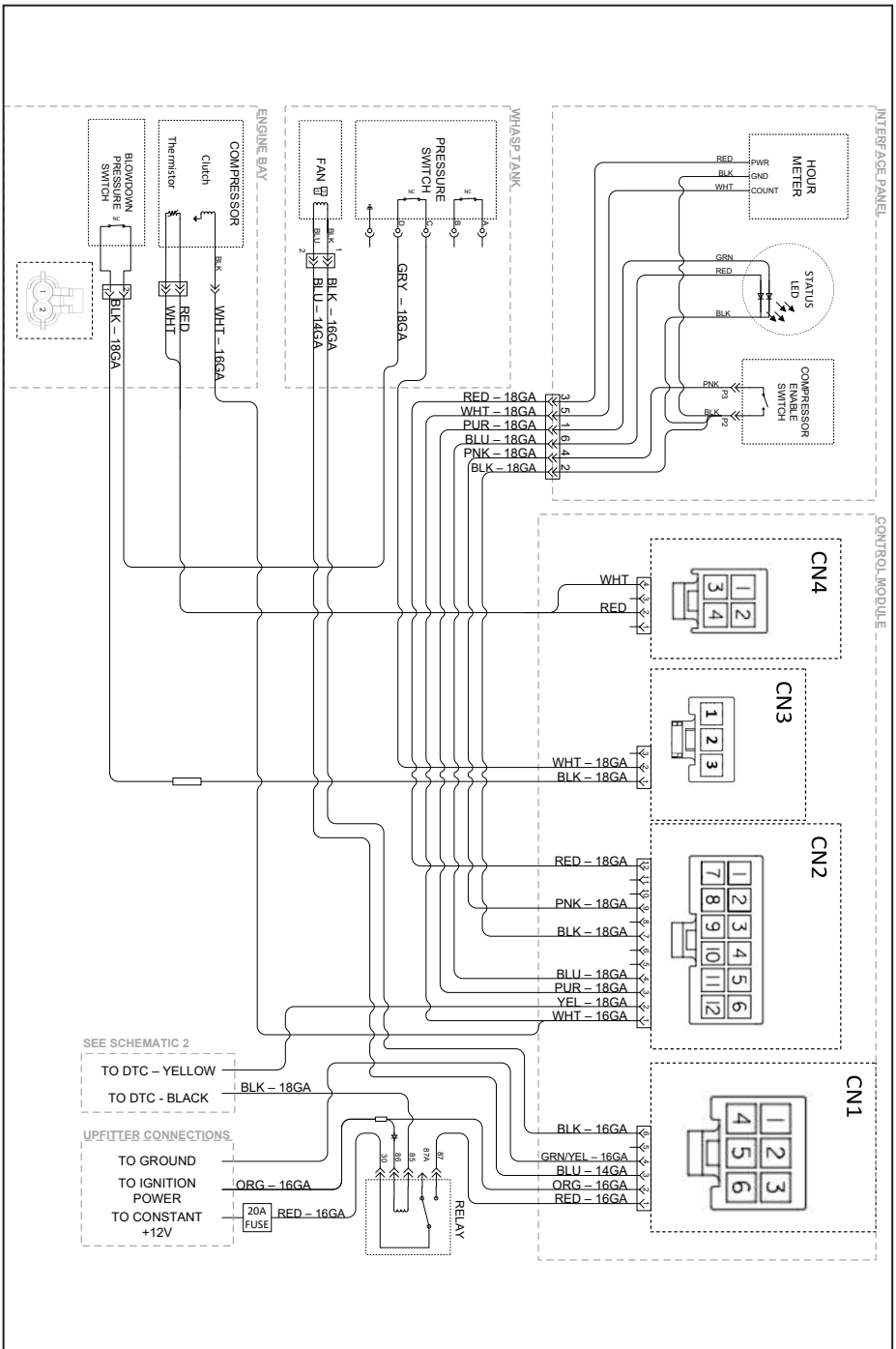

Figure 44 — Electrical schematic 1

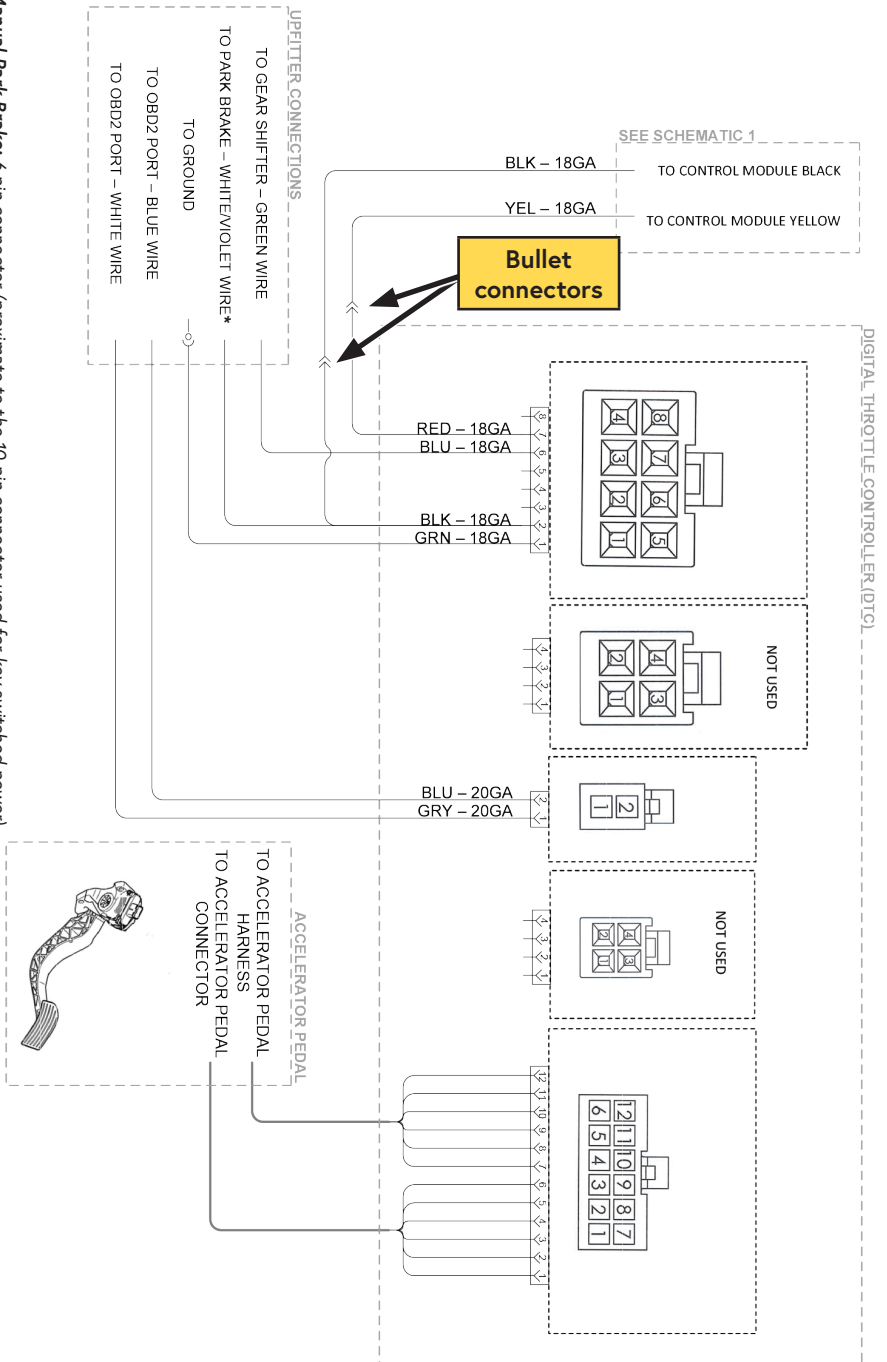

Figure 45 — Electrical schematic 2

\*Manual Park Brake: 6 pin connector (proximate to the 10 pin connector used for key switched power).  
 \*VMAC A700327: Black wire from A700327.

## Control Module

- Remove the plastic trim panel from the doorsill and the kick panel on the driver side, and the lower dashboard panel (below the steering wheel).
- Plug the (x4) harnesses into the control module.
- Install the control module up and out of the way of the pedals, steering column, and the park brake mechanism.

## Throttle Control

- Using cable ties, secure the throttle control under the dashboard, next to the OBD II port. Ensure it is away from moving parts and positioned so that the buttons and LED lights are accessible.

## Connecting the Wiring

- Unplug the OEM cable from the accelerator pedal and plug it into the matching connector from the throttle control. Plug the cable from the throttle control into the matching connector on the accelerator pedal.
- Connect the bullet connector from the yellow wire, running from the control module, to the matching connector on the red wire running from the throttle control.
- Connect the green ground wires from the throttle control and control module to a chassis ground point.
- Connect the bullet connector from black wire running from control box power relay to the matching connector on the black wire running from the throttle control.
- Locate the OBD II port (generally located under the dashboard, beneath the steering wheel column) (Figure 46).

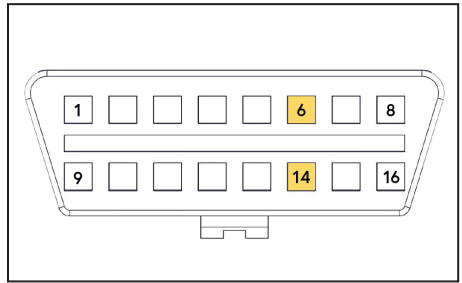
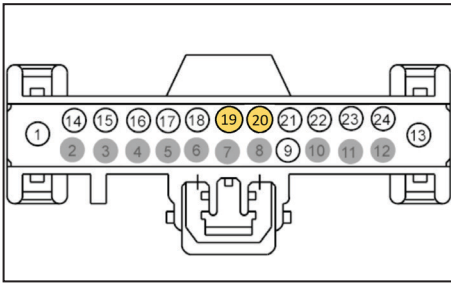

Figure 46 — Identify OBD II port.

- Remove the fasteners securing the OBD II port to the dashboard; this provides easier access to the wires at the back.
- Peel back the tape on the harness a few inches.



***The wires populating pins 19 and 20 on the back of the OBD II are a twisted pair (blue wire and white wire).***

- Splice the light blue wire from the throttle control to the wire at pin 20 (24 pin port) or pin 6 (16 pin port) of the OBD II port (blue wire at the time of writing)
- Splice the grey wire from the throttle control to the wire at pin 19 (24 pin port) or pin 14 (16 pin port) of the OBD II port (white wire at the time of writing).



- From the passenger side of the lower dashboard, remove the (x2) screws securing the shifter console (Figure 47).

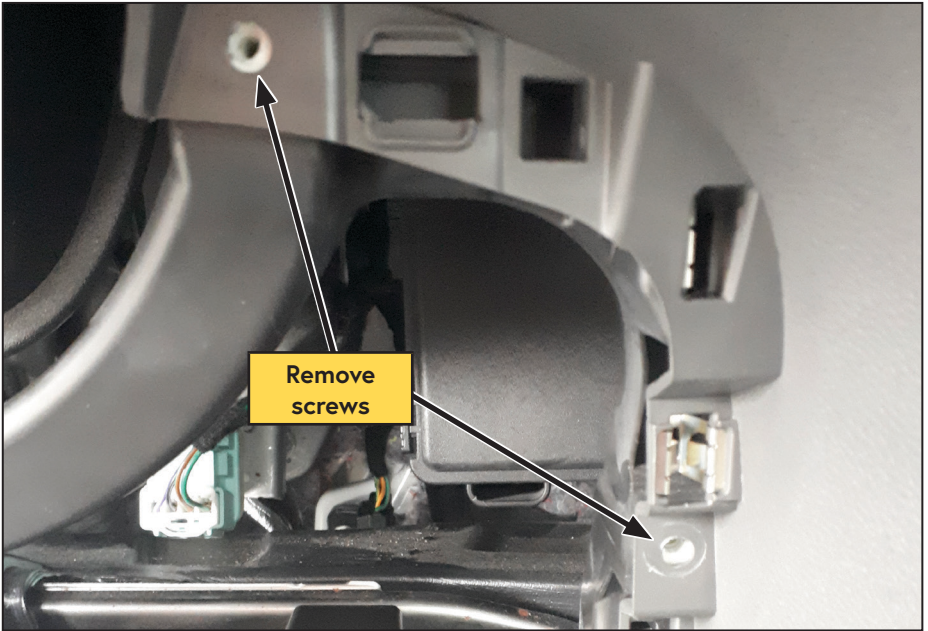

Figure 47 — Remove shifter console

- Lift the gear indicator panel up (Figure 48).



Figure 48 — Remove gear indicator panel

- Remove trim panel to access shifter console retaining clip (Figure 49).



Figure 49 — Remove shifter console

- Open the glove box.
- Rotate the shifter console toward the passenger side (Figure 50).



Figure 50 — Rotate shifter console

- Disconnect the 12 pin harness located on the passenger side of the gear selector (Figure 51).

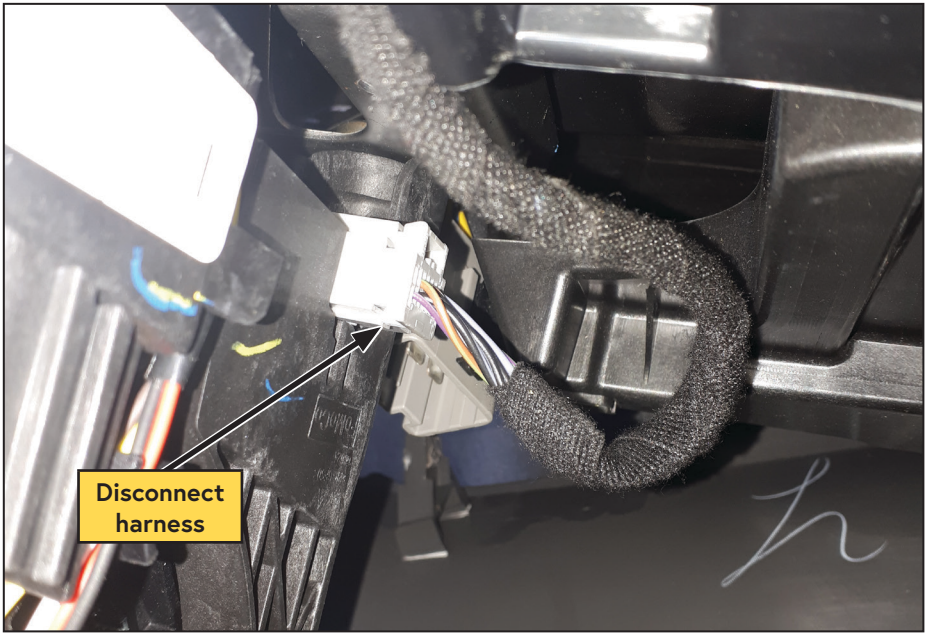

Figure 51 — Remove shifter console

- Splice the blue wire from the throttle control to the green wire at pin 9 of the gear selector connector (CET52) (Figure 52).

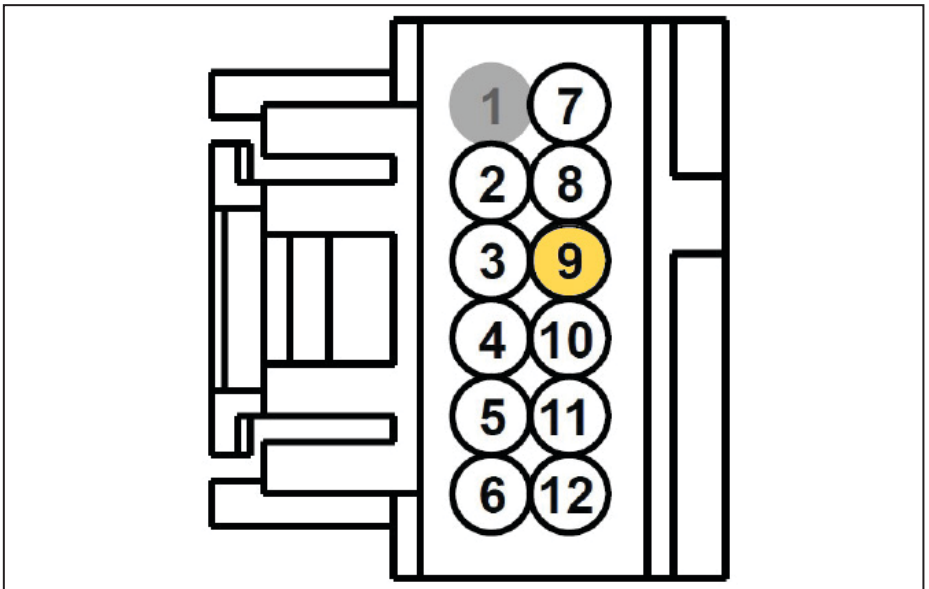

Figure 52 — Connect gear selector

- Apply approximately 36 in of the supplied loom to the gear selector harness to protect it from abrasion or wear.
- Cut the loop of grey wire from the black module on DTC main harness the (Figure 53).

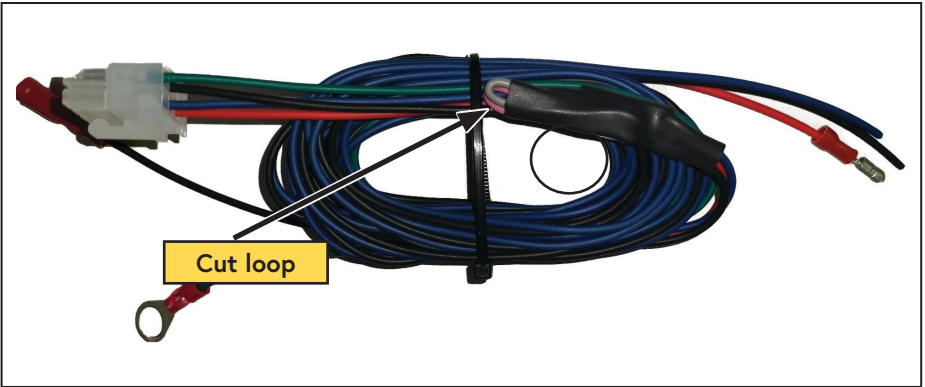

Figure 53 — Disable pull up harness

Bundle the following wires together and cover them with loom:\*

- \*Red wire running from the control module.
- \*Orange wire running from the control module.
- \*Black wire running from the throttle control.
- Remove the driver side door weather stripping from the channel, and route the loomed wires between the channel and the driver side floor (Figure 54).



Figure 54 — Route wires

- Route the loomed wires along the inside of the driver door and underneath the driver side step, towards the driver side seat support (Figure 55).

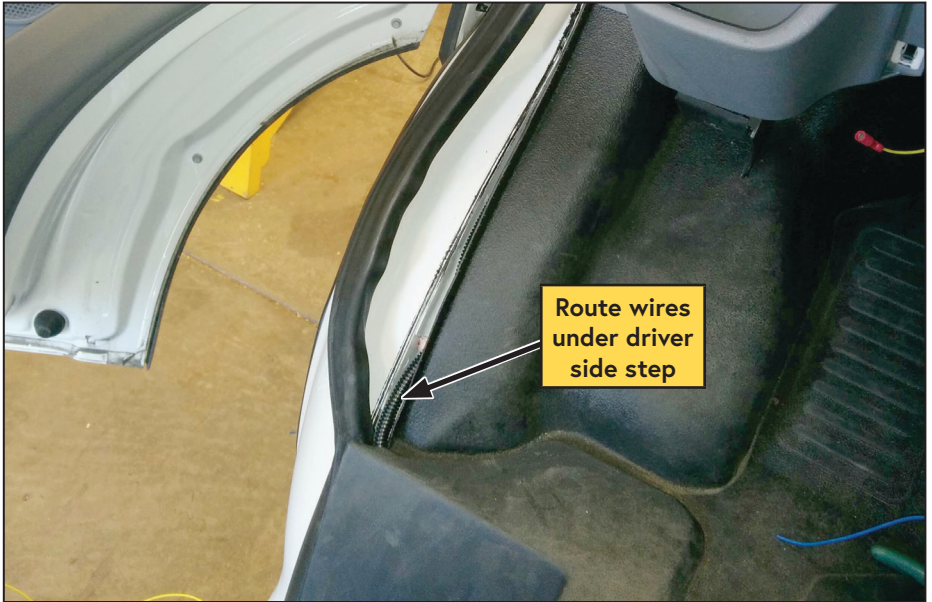

Figure 55 — Driver side step

- Route the loomed wires through the gap in the driver side seat support (Figure 56).

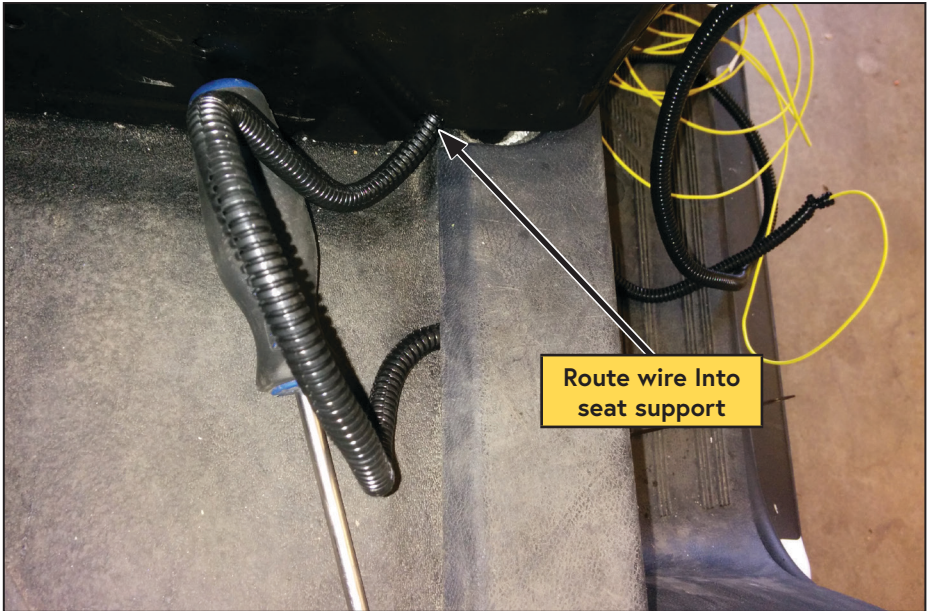

Figure 56 — Driver side seat support

- Crimp the supplied fuse holder to the red wire running from the control module. Ensure the fuse holder is installed as close to the power source as possible.
- Connect the other end of the fuse holder to the positive battery terminal. (Figure 57).

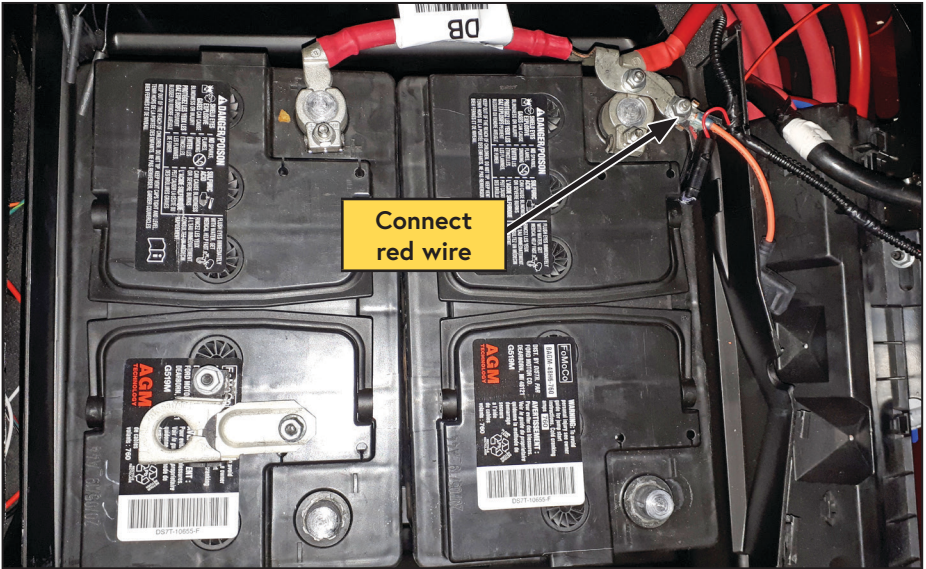

Figure 57 — Connect power

- Locate the 10 pin connector between the positive side of the batteries and the battery box (Figure 58).

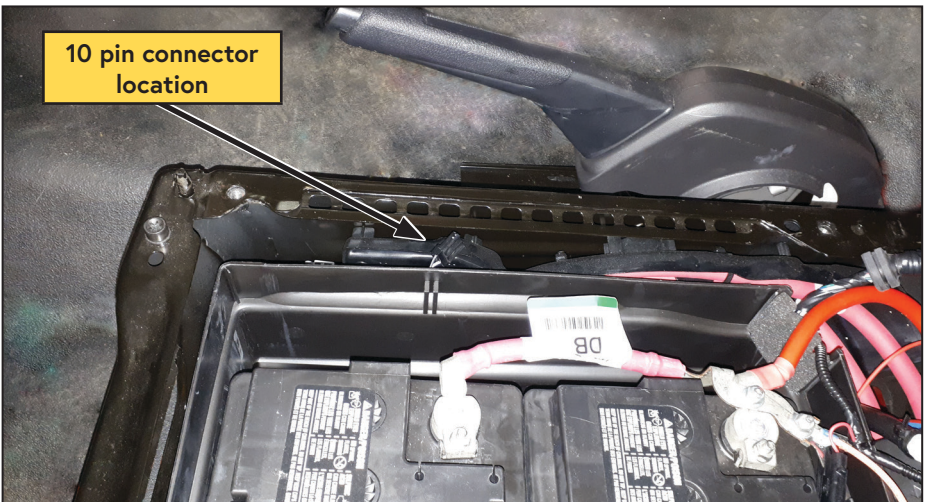

Figure 58 — Connect key switched power

- Connect the orange wire, running from the control module, into pin 6 (key switched power) of the 10 pin connector. \*If pin 6 is already populated, splice the orange wire into the existing wire populating pin 6 (Figure 59).

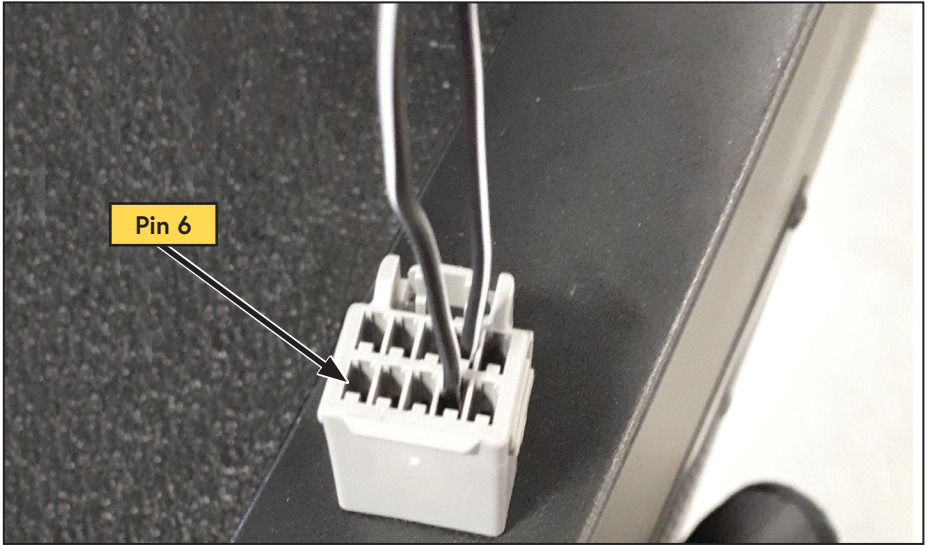

Figure 59 — Connect key switched power

## Park Brake signal

### *Manual Park Brake*

Splice the black wire, running from the throttle control, to the white wire with violet stripe located at either:\*

- \*Manual Park Brake: The park brake switch.
- \*The 6 pin connector (proximate to the 10 pin connector located above).

### *Using VMAC Upfitter Interface Module(P/N: A700327)*

- Splice the black wire, running from the throttle control, to the black wire on the A700327.

Route the following wires into the engine compartment via a grommet in the firewall\*:

- \*White 16 AWG wire with bullet connector running from the CN2 connector on the control module.
- \*Grey cable with the green connector from the control box.
- Cover all of the engine compartment wires with plastic loom.
- Route the wire bundle toward the coolant overflow bottle (located on the driver side of the engine bay).
- Optional:** To provide better access to the Powertrain Control Module (PCM), remove the fasteners securing the overflow bottle and shift it out of the way.
- From the PCM, route the white clutch wire and grey temperature sensor cable down toward the engine oil filter.

- From the PCM, route the white clutch wire and grey temperature sensor cable down toward the engine oil filter.
- Bundle the white wire and grey cable together with the compressor hoses routed earlier in the installation.
- Follow the hose routing path under the engine oil pan and over the front subframe crossmember, towards the passenger side of the vehicle (Figure 34 on page 29).
- Connect the green connector on the grey cable to the matching connector on the compressor.
- Connect the blue bullet connector on the white wire to the matching connector on the compressor.
- Connect the 2 pin connector on the pressure switch harness into the pressure switch on the compressor.
- Route the pressure switch harness (black 18 AWG, and grey 18 AWG wires) into the cab.
- Route the black 18 AWG wire running from the pressure switch harness to the to the control module.
- Using a butt splice supplied with the pressure switch harness, splice the black wire running from the pressure switch to the black wire running from pin 1 of the CN3 connector.
- Bundle the grey 18 AWG wire running from the pressure switch harness, the white wire running from the CN3 connector, and the black and blue wire harness running from the CN1 connector together.
- Route the wire bundle to the WHASP Tank.
- Route the harness from CN2 of the control module to the interface panel.



*A spare bullet connector is provided to allow the clutch wire to be shortened.*

### Interface Panel

- Install the Interface Panel in a suitable location (Figure 60).

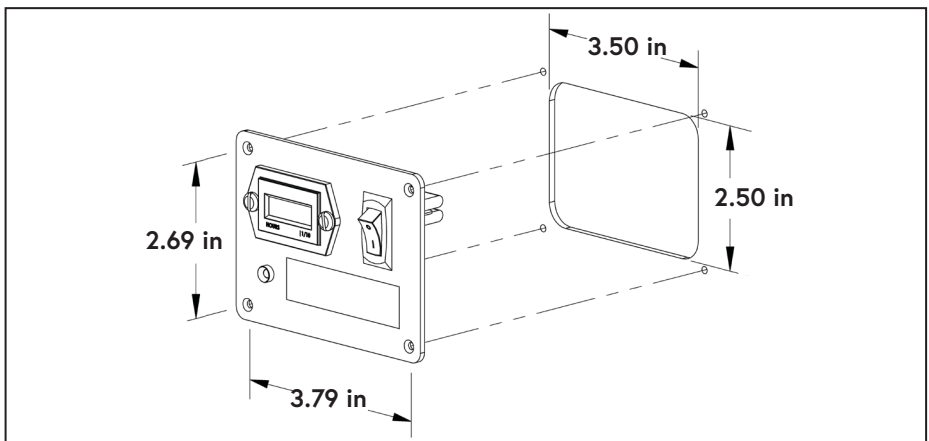

**Figure 60 — Interface Panel mounting dimensions**



- Connect the harness from CN2 of control module to the interface panel.
- Connect the fan connector from CN1 of the control module to the plug on the WHASP Tank.
- Connect the ring terminals from the white wire running from CN3 of the control module, and the grey wire running from the pressure switch harness to the pressure switch on the WHASP Tank (these are not polarity dependent) (Figure 61).

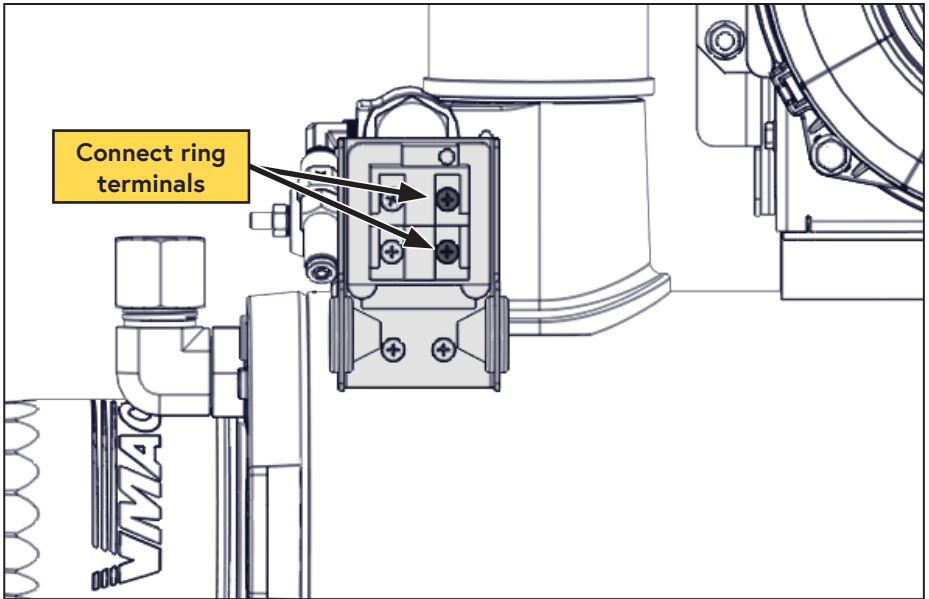

Figure 61 — Connect pressure switch

- Ensure all wires and harnesses are protected with loom and routed away from sharp, hot, or moving components and away from high traffic areas.
- Replace the cover when finished.



*The WHASP Tank harnesses are made to a generic length. Any excess harness should be coiled up and secured out of the way. There are 2 extra ring terminals included with the pressure switch harness; if desired, cut the harness to length and crimp the spare ring connectors to it.*

# Installing the Air Filter and Power Steering Reservoir



The VMAC air filter fastener pack is shared between the V400034 (3.5 L Duratec) and the V400029 (3.5 L Ecoboost) kits. Please discard the parts that are not used.

- Mount the VMAC air filter assembly to the supplied bracket using the supplied M6 nylon lock nuts (Figure 62).

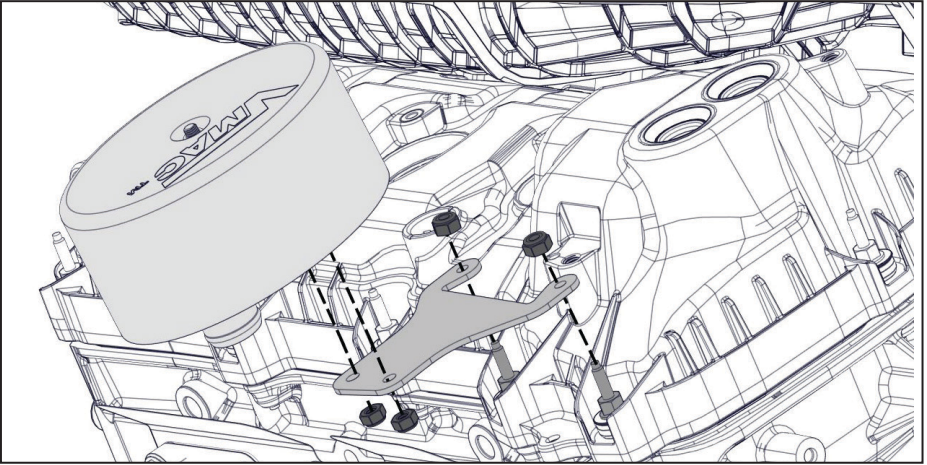

**Figure 62 — Air filter and bracket**  
(A/C compressor removed for clarity)

- Using the (x2) supplied M5 nuts, mount the VMAC air filter and bracket assembly to the front valve cover studs (Figure 62).
- Cut 8 in from the straight end of the intake hose assembly (Figure 63).

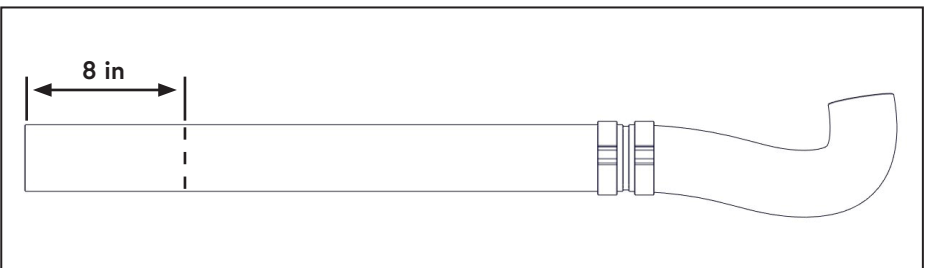

**Figure 63 — Modify air intake hose**

- Connect the compressor intake tube to the spigot on the air filter assembly and secure it with a hose clamp.

## Completing the Installation

- Check all VMAC and OEM wiring to ensure it will not contact any hot, sharp or moving components and will not interfere with the operation of the vehicle. Secure all wiring with rubber coated P-clips, cable ties and loom as required.
- Check all VMAC and OEM hoses and tubes to ensure they will not contact any hot, sharp or moving components and will not interfere with the operation of the vehicle. Secure all hoses and tubes with rubber coated P-clips, cable ties and loom as required.
- Reinstall the headlights.
- Reinstall the coolant overflow bottle.
- Reinstall the driver seat.
- Reinstall the seat electrical connector.
- Replace all dashboard panels and kick plates that were removed.
- Reconnect the batteries and install the cover.
- Affix the safety and operational instruction decal in an obvious location so that it can be seen by vehicle operators. A good spot for this is usually on the inside of the door or on the panel underneath the steering wheel (Figure 64).



Figure 64 — Advisory label



*The VMAC warranty form must be completed and returned to VMAC at the time of installation for any subsequent warranty claim to be considered valid.*

- Complete the warranty form. The VMAC warranty form is located at the back of this manual, as well as online at: [www.vmacair.com/warranty](http://www.vmacair.com/warranty)



- Affixed the safety and operational instruction decal in an obvious location so that it can be seen by vehicle operators. A good spot for this is usually on the inside of the door or on the panel underneath the steering wheel (Figure 65).

**VMAC**  
VEHICLE MOUNTED AIR COMPRESSORS

This vehicle is equipped with a  
VMAC Air Compressor System.

**OPERATING INSTRUCTIONS**

**Daily Pre Start Check:**

1. Check oil level in tank.
2. Check drive belt system.
3. Check for leaks.

**Start Up Procedure:**

1. Ensure air system is depressurized.
2. Ensure all air outlets are CLOSED.
3. Place vehicle in Neutral or Park and engage park brake.
4. Start engine and bring to operating temperature.
5. Turn ON compressor.

**Shutdown Procedure:**

1. Ensure discharge valve is CLOSED.
2. Allow engine to idle for 1 minute.
3. Turn OFF compressor.
4. Wait for system to depressurize before restarting.

For Technical Support/Parts contact your VMAC Dealer  
To locate your nearest dealer call 1-800-738-8622 (250-740-3200)

4400644-A

**⚠ WARNING**  
**Always allow system to depressurize before restarting**

Figure 65 — Operating Instruction label

- Install the VMAC belt routing diagram in a suitable location under the hood.

*The System Identification Plate must be attached to the vehicle at the time of installation. This plate provides information that allows VMAC to assist with parts and repairs.*

- Locate a conspicuous area in the engine bay (where the tag will be easily noticed) to install the System ID tag.
- Mark and drill (x2) 7/64 in holes and secure the plate with the supplied self-tapping screws (Figure 66).

4400346D

**VMAC**  
VEHICLE MOUNTED AIR COMPRESSORS

**SYSTEM ID NUMBER**

Figure 66 — System Identification Plate

# Air Receiver Tank



*Pressure in the air receiver tank will not be relieved when the compressor system blows down. This is normal operation. Prior to performing any service work on the system, discharge any stored air in the air receiver tank.*



*The VMAC WHASP Tank has a built-in check valve. Use of an additional check valve is not required and may cause erratic performance.*

The VMAC compressor system automatically depressurizes when it is shut-down. The WHASP Tank has a built in 1-way check valve which prevents blow back and moisture from the receiver tank entering the WHASP Tank. Installation of an additional check valve will cause erratic performance.

While the air receiver tank can be installed at any height in relation to the WHASP Tank, the discharge hose running from the WHASP Tank must be installed as high as possible on the air receiver tank to prevent problems with condensation that may have accumulated in the receiver tank (Figure 67).

Drain the condensed water from the receiver tank daily.

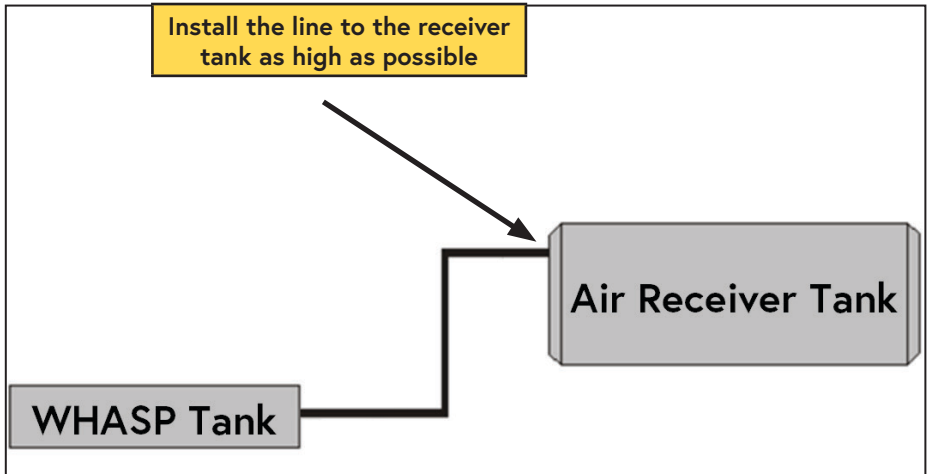

Figure 67 — Air receiver tank

## Recommended Accessories

While the compressor system will function without the following accessories, VMAC strongly recommends their use for optimal performance.

See the "Accessory Product" section of this manual on page 59 for a list of products available for purchase through VMAC.

### Larger Air Receiver Tank

A larger capacity air receiver tank provides a larger buffer as it gives the compressor time to react by increasing the engine speed and producing air before the tool stalls. It also has the advantage of lowering the duty cycle of the compressor system.

*(This application requires a minimum air receiver tank size of 6 USG).*

### Pressure Gauge

While not critical to system performance, a pressure gauge is important for fine tuning the system and simplifies any potential troubleshooting.

Install a 200 psi pressure gauge downstream of the air discharge valve.

### Pressure Regulator and/or Lubricator or FRL

The compressor can produce air pressures up to approximately 150 psi (1035 kPa). It is the responsibility of the user to know the pressure and air flow requirements of the tools powered by the air compressor system.

An appropriate air pressure regulator and lubricator can be installed downstream of the air discharge valve. Failure to regulate the air pressure may cause damage to the tool.

# Testing the Installation



*Lift the vehicle, ensuring the driven wheels are off of the ground. Support the vehicle securely with appropriately rated jack stands. Ensure there are no people around the vehicle before beginning the test.*

*If the vehicle fails the test, ensure the wiring to all of the connections are correct and secure. If additional assistance is required, contact your local VMAC dealer or call VMAC Technical Support 1-888-241-2289 or 250-740-3200.*

## Safety Test

Ensure the following has been completed:

- Place the transmission in "PARK" and apply the park brake. Turn the ignition key to "ON" but do not start the engine.
- Turn on the compressor and listen for the compressor clutch to engage.
- Observe the hour meter, and ensure the hourglass icon is blinking.
- Turn off the compressor switch and ensure the clutch has disengaged.

## Before Starting the Engine Checklist

Ensure the following has been completed:

- Check that the compressor oil level at the tank sight glass is correct.
- Complete a final inspection of the installation to ensure everything has been completed.
- Perform a final belt alignment check.
- Check all wiring for security and protection. Ensure nothing is touching the compressor body.
- Ensure all of the compressor outlets are closed.
- Ensure the parking brake is engaged and the transmission is in "PARK".
- Start the engine.

## After Starting the Engine Checklist

- Allow the vehicle to reach operating temperature.
- Turn on the compressor. The compressor clutch should engage, and the engine speed should increase in response to the throttle control. The vehicle's tachometer should indicate approximately 2,200 rpm.
- Once the engine speed reduces to base idle, turn off the compressor.
- Shut down the engine.
- Check the compressor oil level after the engine has been shut down and the oil level has had time to stabilize.



**Ensure any stored air is drained from the system prior to adding oil.**

- Add oil as necessary to bring the level to the "FULL" line in the sight glass and check for leaks.
- Install the VMAC Air Test Tool (P/N: A700052) with the 40 cfm (5/32 in) orifice installed and the ball valve closed.
- Start the engine. Assistance may be required for the next steps.



**The following tests confirm that the drive disable system is working correctly. The drive disable system prevents the VMAC throttle from increasing engine rpm unless the transmission is in "PARK" and the park brake is engaged (it does not disengage the clutch!).**

**2 people are required to perform this safety test. 1 person must remain in the driver seat and be prepared to actuate the service (foot) brake if necessary.**

**The second person will actuate the compressor switch and ball valve as necessary.**

- With the engine running and the vehicle in "PARK", release the parking brake. Turn on the compressor and open the ball valve.
  - The clutch should engage, but engine speed should NOT increase.
  - \*The "STATUS" and "PRK BRAKE" LED's on the digital throttle control will turn off.
- Close the ball valve.
- Turn off the compressor.
- Reapply the park brake.



**The steps marked with asterisks will be repeated.**

- \*With the engine running, depress the service (foot) brake and shift the transmission out of "PARK".
- \*Turn on the compressor and open the ball valve.
  - The clutch should engage, but engine speed should NOT increase.
  - \*The "STATUS" and "PRNDL" LED's on the digital throttle control will turn off.
- \*Close the ball valve.
- \*Turn off the compressor.
- \*Drain any accumulated air from the system.
- \*Shift the transmission into "PARK".
- Repeat the steps marked with asterisks for all transmission selector positions, returning the gear selector to "PARK" and cycling the compressor "OFF", then "ON" after each gear is tested.





***Engine speed should not increase unless the vehicle is in "PARK" or "NEUTRAL".***

- Drain any air that may have accumulated during the previous tests.
- Ensure the parking brake is engaged.
- Turn on the compressor and open the ball valve.
- Release the park brake. The engine speed should drop to base idle.
- Close the ball valve.
- Turn off the compressor.
- Reapply the park brake.
- Shut down the engine.
- Drain any accumulated air from the system.

## Digital Throttle Auto Calibration



***When first installed, the VMAC digital throttle will perform an auto-calibration as it adjusts to the vehicle's tune, this process takes approximately 3 minutes.***

- Remove the orifice from the VMAC Air Test Tool.
- Open the ball valve slowly, until the system maintains approximately 85 psi.
- Allow the system to run for 3 minutes while the VMAC digital throttle calibrates itself. During this time, engine speed may gradually increase until achieving the maximum VMAC rpm (2,650 rpm).
- Close the ball valve.
- Allow the compressor to run until the system reaches full system pressure.
- Confirm all air valves are closed and the system has no air leaks.
- Turn off the compressor.
- Ensure any stored air is drained from the system.

## Final Testing

**Ensure the following has been completed:**

- Operate the system with an air tool (or the VMAC Air Test Tool with the appropriate orifice installed) for at least 1/2 hour (1 hour preferred).



***The WHASP Tank cooling fan is thermostatically controlled, and may start or stop without warning.***

- Road test the vehicle for approximately 20 km (14 miles).
- Observe the compressor while it is operating to ensure the belts rotate properly, pulleys rotate smoothly and nothing is rubbing or contacting hot parts.

Once the engine is turned off and the system has cooled:

- Check all components, connections and fasteners.
- Check the compressor oil level.

**VMAC - Vehicle Mounted Air Compressors**

VMAC Technical Support: 888-241-2289

VMAC Knowledge Base: kb.vmacair.com

# Performance Testing and System Adjustments

System operation can be tested using the tools that will be operated by the system or by using the VMAC Test Tool (A700052) with the 40 cfm (5/32 in) orifice in the outlet to simulate tool use (Figure 68).

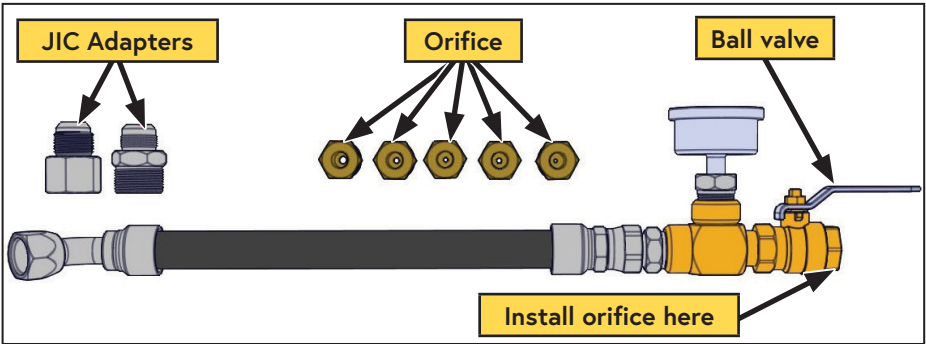

Figure 68 — A700052 VMAC Air Test Tool



**Disconnect all downstream equipment (hose reels, etc.) and connect the test tool directly to the discharge fitting on the WHASP Tank.**

**Ensure there are no leaks in the test tool. The system may not idle down if there are leaks in the lines or fittings.**

- Install the VMAC test tool at the system outlet with the 40 cfm (5/32 in) orifice.
  - Ensure the ball valve is closed.
  - Place the transmission in "PARK" and fully apply the park brake.
  - Allow the engine to run until it is at operating temperature.
  - Turn on the air compressor system and allow it to operate until the oil is warm.
  - Observe the pressure gauge. Pressure should be approximately 150 psi.
- Open the ball valve on the test tool and observe the engine tachometer:
- Engine speed should increase to approximately 2,650 rpm.
  - Close the air valve slowly to allow the system pressure to rise. When the pressure reaches the pressure switch set-point of 150 psi, the system will disengage the compressor clutch and reduce the engine speed to base idle.
  - Once the system pressure is at maximum pressure, slowly open the ball valve on the test tool until the pressure on the gauge begins to drop. Engine speed should ramp up to approximately 2,650 rpm when the pressure drops approximately 40 psi below the pressure switch set-point.

# Digital Throttle Control Operation and Adjustments

The throttle control is configured at the factory for optimum performance at maximum cfm. In applications where maximum cfm is not required, or noise is a concern, the throttle control can be adjusted to reduce the maximum VMAC rpm.

## Safety features

The throttle control has built in safety features that will disable the system if an unsafe condition is detected, or either of the lock out parameters is not met (the vehicle must be in "PARK" and the park brake must be engaged).

If an unsafe condition is detected, the "STATUS" LED will turn off, and engine speed will return to idle. Once all unsafe conditions have been removed, the system must be cycled off, then on again to reset it. Once the system powers up, the "STATUS" LED will illuminate, and the system will operate normally.

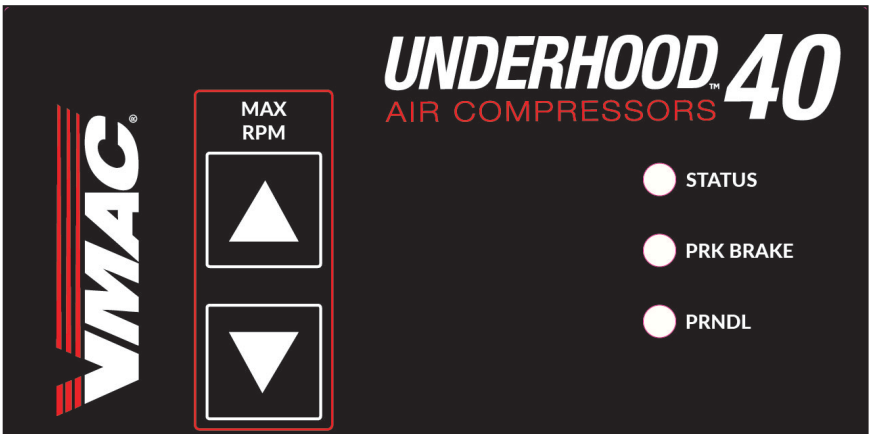

Figure 69 — Throttle control



*If the vehicle is placed into gear, or the park brake disengaged, the "STATUS" LED and the "PRNDL" or "PRK BRAKE" LED will turn off and the throttle control will deactivate. This will reduce engine speed to base idle.*

*In order to activate the system again, re-engage the appropriate lockout and cycle the VMAC "OFF" then "ON" via the control box.*



*For more information on the digital throttle, including error codes, see the related article the VMAC Knowledge Base:*

*<https://kb.vmacair.com/help/vmac-digital-throttle-control>*





*In order to perform a factory reset, or adjust the "MAX RPM", the throttle needs to be active and engine rpm elevated; VMAC recommends installing the VMAC Air Test Tool (P/N: A700052) with the 40 cfm (5/32 in) orifice. Turn the system on and open the ball valve, allowing the engine speed to increase.*

## MAX RPM

The cfm produced by the system is directly related to engine speed; this system delivers 40 cfm at 2,650 rpm.

Maximum VMAC rpm can be adjusted between 1,500 rpm and 2,900 rpm (in 50 rpm increments) via the "▲" or "▼" buttons in the "MAX RPM" column.

## Factory Reset

The throttle control can be reset to factory default values via a button inside the throttle control box.

Using a paper clip (or similar object), push and hold the factory reset button for 5 seconds. All of the LED lights will illuminate for several seconds while the settings revert to their defaults. Once the LED's return to their normal state, the system is ready for use again (Figure 70).

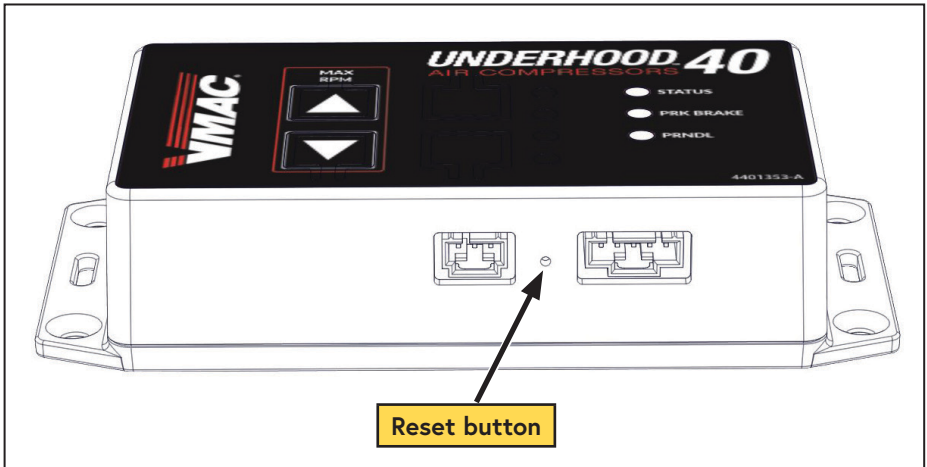

Figure 70 — Reset button

# Accessory Products from VMAC

## Compressor Service Kits



**200 Hour or 6 Month Service Kit -**

**Part number: A700263**

Includes 4 L VMAC high performance compressor oil, oil filter, air filter, and next service due decal.

**400 Hour or 1-Year Service Kit -**

**Part number: A700264**

Includes 4 L VMAC high performance compressor oil, oil filter, air filter, spin-on oil separator, safety valve, muffler, and next service due decal.

---

## Bulkhead Fittings

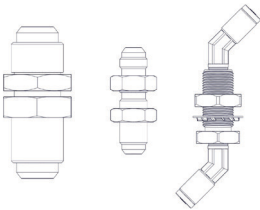

**Part number: 3801095**

**Includes:**

**Bulkhead fittings are used for passing the system discharge, oil, and scavenge hoses through the floor or body panels.**

- 3/4 in JIC bulkhead fitting P/N: 4900170.
- 3/8 in JIC bulkhead fitting P/N: 4900209.
- 1/8 in NPT bulkhead fitting P/N: 5000178.
- 2 x 45° 1/4 push-to-connect fittings P/N: 5000158.

---

## Hose Fittings

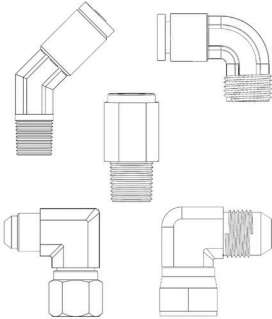

**45° 1/4 push-to-connect fitting P/N: 5000158.**

1/4 in push-to-connect fitting For PTFE scavenge tube.

**90° 1/4 push-to-connect fitting P/N: 5000020.**

1/4 in push-to-connect fitting For PTFE scavenge tube.

**Straight 1/4 in push-to-connect fitting P/N: 5000012.**

1/4 in push-to-connect fitting For PTFE scavenge tube.

**90° 3/8 in hose fitting P/N: 4900117.**

3/8 in hose fitting for Oil Return Hose.

**90° 3/4 in hose fitting P/N: 4900043.**

3/8 in hose fitting for Compressor Discharge Hose.

---

## 1/2 in x 50 ft Hose Reel

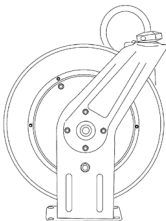

**Part number: A700007**

Spring-loaded 1/2 in x 50 ft hose reel; steel construction; full flow shaft and swivel for maximum performance.

## 6 Gallon Air Receiver Wing Tank

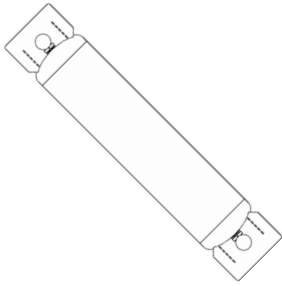

### Part number: A300056

Air receiver tanks are used for lowering compressor duty cycle and removing water from compressed air; recommended for optimum operation of all VMAC Gas Driven, Diesel Driven, Hydraulic, and UNDERHOOD40 air compressors. Manufactured to FMVSS 121 standard; includes fittings, 170 psi pressure relief valve, and tank drain.

- Max pressure: up to 170 psi.
- Dimensions: 32 in (81.3 cm) L x 8 in (20.3 cm) D.
- Weight: 23 lb (10.4 kg).

---

## 10 Gallon Air Receiver Tank w/ Mounting Feet



### Part number: A300047

Air receiver tanks are used for lowering compressor duty cycle and removing water from compressed air. Recommended for optimum operation of VMAC Hydraulic Air Compressors, VMAC Diesel Driven Air Compressors, UNDERHOOD40, UNDERHOOD70 – Green Series Air Compressors, and VMAC Multifunction Power Systems, which include standby mode; ASME certified; includes fittings, 200 psi pressure relief valve, tank drain, and 200 psi pressure gauge.

- Max pressure: up to 200 psi.
- Dimensions: 30 in (76.2 cm) L x 10 in (25.4 cm) D.
- Weight: 33 lb (15 kg).

---

## 35 Gallon Air Receiver Wing Tank

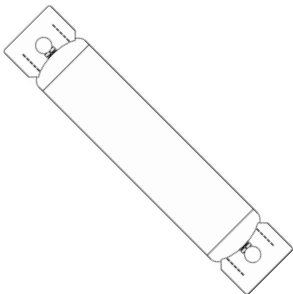

### Part number: A300010

Air receiver tanks are used for lowering compressor duty cycle and removing water from compressed air. Recommended for optimum operation of VMAC Diesel Air Compressors, Hydraulic Air Compressors, UNDERHOOD40, UNDERHOOD70 – Green Series Air Compressors, and VMAC Multifunction Power Systems, which include standby mode; ASME certified; includes fittings, 200 psi pressure relief valve, tank drain, and 200 psi pressure gauge.

- Max pressure: up to 200 psi.
- Dimensions: 73 3/4 in (187.3 cm) L x 14 in (35.6 cm) D.
- Weight: 95 lb (43.1 kg).

## UNDERHOOD 70 Air Aftercooler

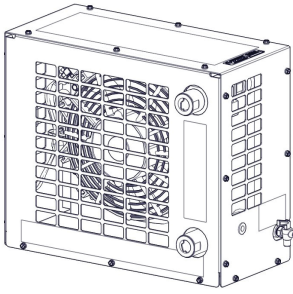

**Part number: A800070**

Improves tool performance and extends the life of air tools; removes up to 80% of water from compressed air; includes automatic water drain.

- Max air flow: 70 cfm / 175 psi.
- Port size: 3/4 in NPT inlet and outlet.
- Electrical: 12 V.
- Dimensions: 17 in (43.2 cm) L x 8.0 in (20.3 cm) W x 14.5 in (36.8 cm) H .
- Weight: 35 lb (15.8 kg).

---

## Filter Regulator Lubricator (FRL) – 70 cfm

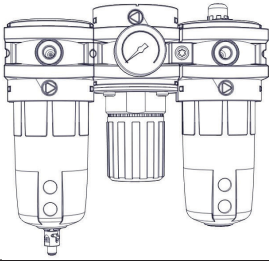

**Part number: A700151**

Extends the life of air tools; filter removes contaminants from the compressed air, adjustable regulator can reduce air pressure going to tools, lubricator adds atomized tool oil to the air stream to lubricate air tools (Tool oil not included).

- Max air flow: up to 70 cfm / 150 psi.
- Port size: 3/4 in NPT inlet and outlet.

---

## Remote Muffler

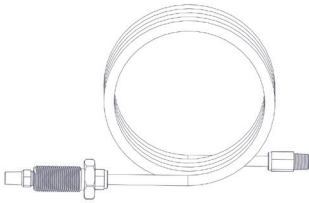

**Part number: A700224**

The A700224 WHASP remote mount muffler kit is designed to relocate the blowdown muffler to an external location. This is recommended for applications where the WHASP Tank will be located inside of a van or service body, the remote mounted muffler will reduce cabin noise when the compressor blowdown operates, and will ensure any oil vapor will be safely discharged outside of the vehicle.

---

## Interface Harness Extension

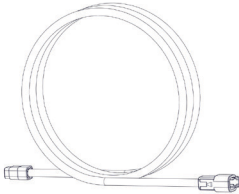

**Part number: A700265**

This interface harness extension provides an additional 10 ft of cable which allows for greater flexibility in locating the Interface Panel.







# Warranty Registration

This form must be fully completed and returned to VMAC at the time the vehicle is put into service. Warranty may be void if this form is not received by VMAC within 3 months of receiving the vehicle, or 200 hours of operation, whichever occurs first.



VMAC's Warranty policy and registration can be viewed online at:

[www.vmacair.com/warranty](http://www.vmacair.com/warranty)

## Product Information

System Identification Number: V \_\_\_\_\_

Compressor Serial Number: P \_\_\_\_\_

## Owner / End User Information

Company Name: \_\_\_\_\_

City: \_\_\_\_\_ State / Province: \_\_\_\_\_

Phone: (\_\_\_\_) \_\_\_\_-\_\_\_\_\_

Email Address: \_\_\_\_\_

Date vehicle was put into service: \_\_\_\_/\_\_\_\_/\_\_\_\_  
Day Month Year

## Installer Information

Installer Company Name: \_\_\_\_\_

City: \_\_\_\_\_ State / Province: \_\_\_\_\_

## Submitted by

Name: \_\_\_\_\_ Phone: (\_\_\_\_) \_\_\_\_-\_\_\_\_\_

Email: \_\_\_\_\_

## Vehicle Information (Optional)

Unit: \_\_\_\_\_ Year: \_\_\_\_\_

Make: \_\_\_\_\_ Model: \_\_\_\_\_

Vehicle Identification Number: \_\_\_\_\_



Manufactured by



888-241-2289



tech@vmacair.com



877-740-3202



warranty@vmacair.com



www.vmacair.com



kb.vmacair.com



1333 Kipp Road, Nanaimo, B.C., V9X 1R3 Canada