

# ***UNDERHOOD***™ **40** AIR COMPRESSORS



## **Installation Manual for VMAC System**

**V400031**

**2020 – 2022 Ford F250 – F600 Super Duty  
7.3 L Gas**

**[www.vmacair.com](http://www.vmacair.com)**



# Table of Contents

Safety .....	3
Warranty .....	4
General Information.....	6
Preparing for Installation .....	8
Installing the Main Bracket and Compressor .....	11
Installing the Waste Heat Air Separator Package (WHASP) Tank ....	17
Hose Requirements .....	20
Connecting the Hoses .....	21
Adding Oil to the System .....	26
Installing the Control System.....	27
Completing the Installation .....	38
Air Receiver Tank.....	40
Recommended Accessories .....	41
Testing the Installation.....	42
Performance Testing and System Adjustments.....	45
Digital Throttle Control Operation and Adjustments .....	46
Accessory Products from VMAC.....	48
Warranty Registration.....	52

Revision	Revision Details	Revised by	Checked by				Implemented
			Eng.		Tech.	Qual.	
			Mech.	Elec.			
A	Initial release	MSP	KRM	AJH	RDB	LPH	21 May 2021
B	ECN: 22-102 Update OBD II connection locations	MSP	N/A	ASE	MSP	LPH	14 Jun. 2022
C	ECN: 23-082 Cap model year	MSP	N/A	N/A	MSP	MSP	18 Apr. 2023

## Additional Application Information

- Use of an air receiver tank (minimum 6 USG) is required with this application.
- 2020 – 2022 Ford F250 – F600 Super Duty 7.3 L Gas.
- Installation of this VMAC system will convert the vehicle to single alternator, please see VMAC Knowledge Base bulletin EXT-UH-005 prior to proceeding.

## Registered Trademarks

All trademarks mentioned in this manual are the property of their respective owners. VMAC's use of manufacturers' trademarks in this manual is for identification of the products only and does not imply any affiliation to, or endorsement of said companies.

**Loctite®**, **Loctite® 242** and **Loctite® 567** are registered trademarks of Henkel AG & Company KGaA.

**Eaton Aeroquip®** is a registered trademark of EATON AEROQUIP INC.

**Torx®** is a registered trademark of Acument Intellectual Properties, LLC

**Ford®** and **Super Duty®** are registered trademarks of Ford Motor Company.

## Important Information

The information in this manual is intended for certified VMAC installers who have been trained in installation and service procedures and/or for anyone with mechanical trade certification who has the tools and equipment to properly and safely perform the installation or service. Do not attempt installation or service without the appropriate mechanical training, knowledge and experience. Follow all safety precautions. Any fabrication for correct fit in modified vehicles must follow industry standard "best practices".

## Notice

Copyright © 2021 VMAC Global Technology Inc. All Rights Reserved. These materials are provided by VMAC for informational purposes only, without representation or warranty of any kind, and VMAC shall not be liable for errors or omissions with respect to the materials. The only warranties for VMAC products and services are those set forth in the express warranty statements accompanying such products and services, if any, and nothing herein shall be construed as constituting an additional warranty. Printing or copying of any page in this document in whole or in part is only permitted for personal use. All other use, copying or reproduction in both print and electronic form of any part of this document without the written consent of VMAC is prohibited. The information contained herein may be changed without prior notice.

**Printed in Canada**



# Safety

## Important Safety Notice

The information contained in this manual is based on sound engineering principles, research, extensive field experience and technical information. Information is constantly changing with the addition of new models, assemblies, service techniques and running OEM changes. If a discrepancy is found in this manual, contact VMAC Technical Support prior to initiating or proceeding with installation, service or repair. Current information may clarify the issue. Anyone with knowledge of such discrepancies, who proceeds to perform service and repair, assumes all risks.

Only proven service procedures are recommended. Anyone who departs from the specific instructions provided in this manual must first ensure that their safety and that of others is not being compromised, and that there will be no adverse effects on the operational safety or performance of the equipment.

VMAC will not be held responsible for any liability, consequential damages, injuries, loss or damage to individuals or to equipment as a result of the failure of anyone to properly adhere to the procedures set out in this manual or standard safety practices.

Safety should be the first consideration when performing any service operations. If there are any questions concerning the procedures in this manual, or more information is required, please contact VMAC Technical Support prior to beginning work.

## Safety Messages

This manual contains various warnings, cautions and notices that must be observed to reduce the risk of personal injury during installation, service or repair and the possibility that improper installation, service or repair may damage the equipment or render it unsafe.



*This symbol is used to call attention to instructions concerning personal safety. Watch for this symbol; it points out important safety precautions, it means, "Attention, become alert! Your personal safety is involved". Read the message that follows and be aware of the possibility of personal injury or death. As it is impossible to warn of every conceivable hazard, common sense and industry standard safety practices must be observed.*



*This symbol is used to call attention to instructions on a specific procedure that if not followed may damage or reduce the useful life of the compressor or other equipment.*



*This symbol is used to call attention to additional instructions or special emphasis on a specific procedure.*

# Warranty

## VMAC Standard Warranty (Limited)

For complete warranty information, including both VMAC Standard Warranty (Limited) and VMAC Lifetime Warranty (Limited) requirements, please refer to our current published warranty located at: [www.vmacair.com/warranty](http://www.vmacair.com/warranty)



If you do not have access to a computer, please contact us and we will be happy to send you our warranty.

VMAC's warranty is subject to change without notice.

## VMAC Lifetime Warranty (Limited)

A VMAC Lifetime Limited Warranty is offered on the base air compressor only and only on UNDERHOOD, Hydraulic Driven, Transmission Mounted, Gas and Diesel Engine Driven Air Compressors, Multifunction Power Systems, and other products as defined by VMAC, provided that (i) the purchaser fully completes and submits a warranty registration form within 3 months of purchase, or 200 hours of operation, whichever occurs first; (ii) services are completed in accordance with the Owner's Manual; (iii) proof of purchase of applicable service kits are made available to VMAC upon request.



The VMAC Lifetime Warranty is applicable to new products shipped on or after 1 October, 2015.

## Warranty Registration

The VMAC warranty registration form is located near the back of this manual. This warranty registration form must be completed and sent to VMAC at the time of installation for any subsequent warranty claim to be considered valid.

There are 4 ways the warranty can be registered with VMAC:



[www.vmacair.com/warranty](http://www.vmacair.com/warranty)



[warranty@vmacair.com](mailto:warranty@vmacair.com)



(877) 740-3202



VMAC - Vehicle Mounted Air Compressors  
1333 Kipp Road, Nanaimo, BC, Canada V9X 1R3

## VMAC Warranty Claim Process



*VMAC warranty work must be pre-authorized by VMAC. Claims are processed via our dealer network. If you are not a VMAC dealer, please select one to work with via our Dealer Locator: <https://www.vmacair.com/dealer-locator/>*



1. Communicate with VMAC Technical Support at 1-888-241-2289 or [tech@vmacair.com](mailto:tech@vmacair.com) to help diagnose/troubleshoot the problem prior to repair. VMAC technical support will require the VMAC System ID, and hours on the compressor.
2. VMAC will provide direction for repair or replacement of the failed components.
3. If requested, failed parts must be returned to VMAC for evaluation.
4. Dealers may login to the VMAC website to view the "VMAC Labour Time Guide" (under "Agreements") to see the allowable warranty labour times.
5. Warranty invoices must include the Service Ticket number, VMAC System ID#, hours on the compressor, and a detailed description of the work performed.
6. VMAC Warranty does not cover consequential damages, overtime charges, mileage, travel time, towing/recovery, cleaning or shop supplies.
7. Dealers submit warranty claims on behalf of the Vehicle Owner/End User affected by the defective part(s). The dealer ensures that all warranty credits are refunded back to the Vehicle Owner/End User who made the initial warranty claim.



*In order to qualify for Lifetime Warranty (Limited), the completed warranty registration form must be received by VMAC within 3 months of the buyer receiving the Product(s), or 200 hours of operation, whichever occurs first.*

*If the completed warranty registration form has not been received by VMAC within 3 months of the buyer receiving the Product(s), or 200 hours of operation, the "Standard" warranty period will be deemed to commence 30 days from the date of shipment from VMAC.*

*Failure to follow the warranty claim process may result in denial of the warranty claim.*

VMAC Product Warranty Policies & Warranty Registration can be found on the VMAC website (see previous page for URL).

# General Information

## Optional Equipment Compatibility

While VMAC strives to design systems compatible with optional OEM equipment (such as running boards), it is impractical to develop systems that accommodate every OEM and aftermarket option or add-on. Whenever possible, VMAC endeavors to advise of compatibility issues in the "Additional Application Information" section of the manual. Even when specific optional equipment is determined by VMAC to be incompatible, it does not preclude the vehicle upfitter or end user from modifying the optional equipment to make it compatible with the installed VMAC system. VMAC does not warrant or accept responsibility or liability for the fitment, function, or safety of any products modified in any way not expressly outlined in the installation manual.

## Before Starting



***Note and label all parts that are removed from the vehicle as many of the OEM parts will be reused during the installation of the VMAC system.***

Read this manual prior to beginning the installation to ensure familiarity with the components and how they will fit on the vehicle. Identify any variations from the application list such as vehicle model, engines, or optional equipment (e.g., dual alternator, active steering assist, etc.).

Open the package, unpack the components and identify them using the Illustrated Parts List (IPL) included in the Fastener Pack.

## Hose Information

Depending on other installed equipment, it might be necessary to move the air/oil separation tank from its intended location. The hoses used in VMAC compressor systems have a specific inner liner that is compatible with VMAC compressor oil. Use of hoses other than those supplied or recommended by VMAC may cause compressor damage and may void your warranty. Please contact VMAC for replacement hoses and further information.

## Ordering Parts

To order parts, contact a VMAC dealer. The dealer will ask for the VMAC serial number, part number, description and quantity. Locate the nearest dealer online at [www.vmacair.com/dealer-locator](http://www.vmacair.com/dealer-locator) or call 1-877-912-6605.



# Special Tools Required

- None

# Torque Specifications

All fasteners must be torqued to specifications. Use manufacturers' torque values for OEM fasteners.

The torque values supplied in Table 1 are intended for VMAC supplied components, or for use as a guide in the absence of a torque value provided by an OEM.

	<p><b>Apply Loctite 242 (blue) to all fasteners (except nylon lock nuts) unless otherwise stated.</b></p>
--	---

Torque values are with Loctite applied unless otherwise specified.

Standard Grade 8 National Coarse Thread								
Size (in)	1/4	5/16	3/8	7/16	1/2	9/16	5/8	3/4
Foot pounds (ft•lb)	9	18	35	55	80	110	170	280
Newton meter (N•m)	12	24	47	74	108	149	230	379

Standard Grade 8 National Fine Thread					
Size (in)	3/8	7/16	1/2	5/8	3/4
Foot pounds (ft•lb)	40	60	90	180	320
Newton meter (N•m)	54	81	122	244	434

Metric Class 10.9						
Size (mm)	M6	M8	M10	M12	M14	M16
Foot pounds (ft•lb)	4.5	19	41	69	104	174
Newton meter (N•m)	6	25	55	93	141	236

Table 1 — Torque Table

# Preparing for Installation



*Preparation for installation is very important. Missing a step or an item can cause problems in the installation or damage to components.*

- Check off each item as it is completed so that no steps are missed.



*Apply Loctite 242 (blue) to all fasteners (except nylon lock nuts) unless otherwise stated.*

- Review the contents of the system using the illustrated parts list to ensure all components are present and in the correct quantity. If any components are missing, have the system ID ready and call VMAC Technical Support at (888) 241-2289.



*Dual alternator vehicles must be converted to single alternator prior to proceeding with the VMAC installation. See EXT-UH-005 on VMAC's Knowledge Base*



*Due to the variety of possible WHASP tank installation locations, VMAC does not include bulkhead fittings or hoses to run between any bulkhead and the WHASP tank. VMAC recommends determining where the WHASP tank will be located early in the installation so that appropriate hose lengths and bulkhead fittings can be ordered. Refer to page 17 for WHASP tank installation requirements.*



*Prior to proceeding, ensure "Transport Mode" has been deactivated (contact a local Ford dealership or refer to the vehicle's owner's manual for instructions).*

- Disconnect the battery(s).
- If equipped:** Remove the battery wires from the routing tray and pass them to the opposite side of the engine; this provides clearance for the install (Figure 1).

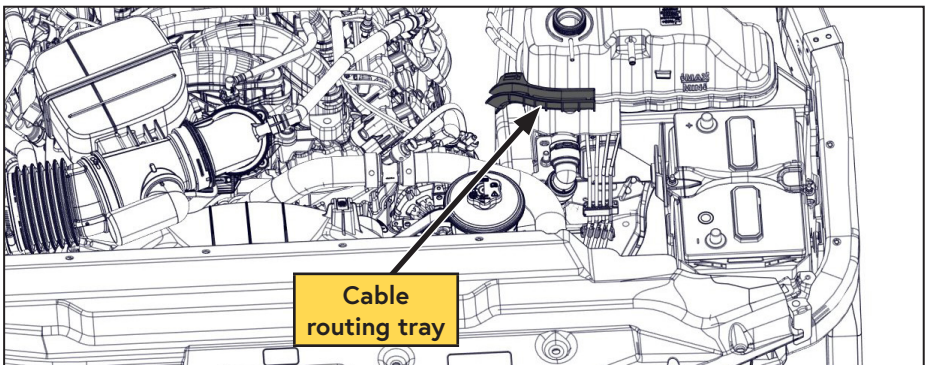

Figure 1 — Secure battery wires out of the way



- Remove the intake tube and cover the ends (Figure 2).

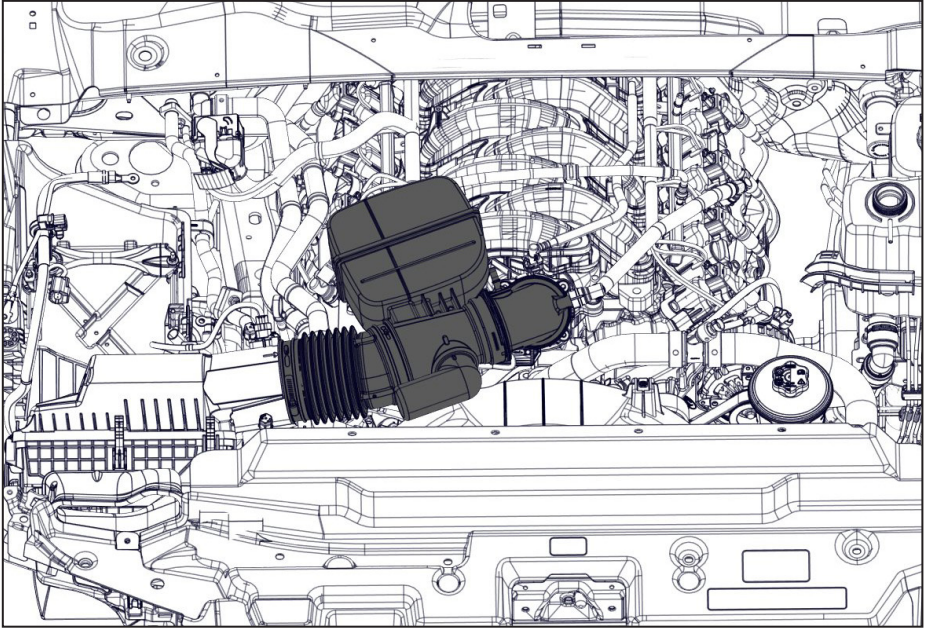

Figure 2 — Remove intake tube

- Disconnect the fan clutch harness.
- Remove the fan clutch stator arm (Figure 3).

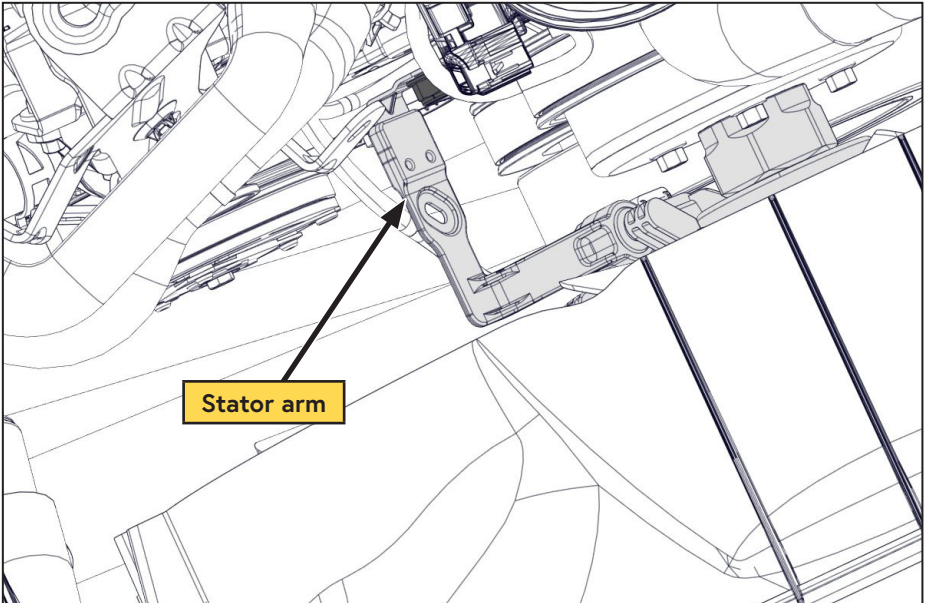

Figure 3 — Remove fan clutch stator arm

- Keeping the power steering lines connected, remove the power steering reservoir from the driver side of the fan shroud.
- Temporarily tie the power steering reservoir up and out of the way of the shroud.



*The power steering reservoir cap will leak if the reservoir is not kept upright.*

- Remove the OEM FEAD belt (this can be accomplished without removing the radiator fan). This can be retained though it will not be used in this installation.
- If equipped:** Remove the secondary alternator (this will not be used in this installation).
- Remove the Primary alternator and fasteners (Figure 4).

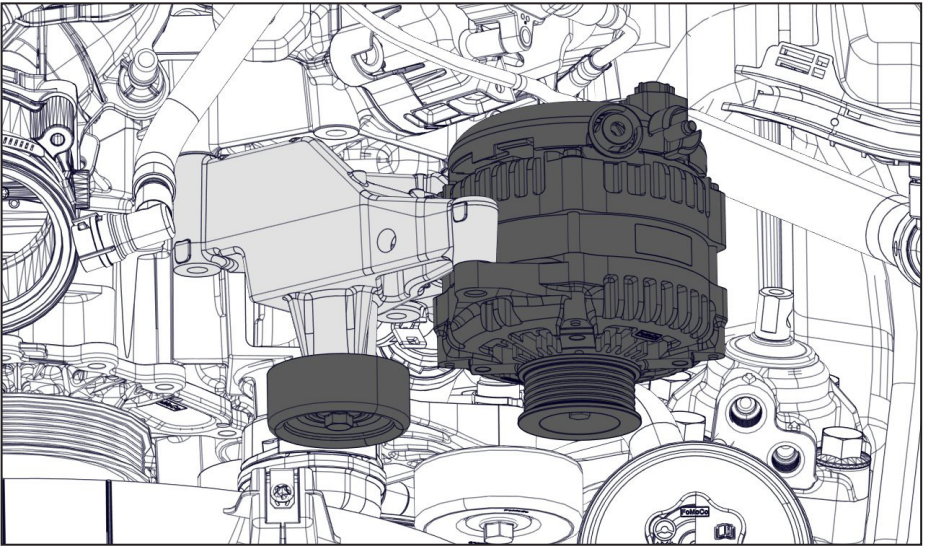

**Figure 4 — Remove alternator, idler, and bracket**  
(Single alternator system shown)

- Remove the idler from the alternator bracket (Figure 4).
- Remove the alternator bracket (Figure 4).
- Remove the idler from the VMAC supplied bracket.



# Installing the Main Bracket and Compressor

- Using (x3) of the OEM fasteners, and the supplied bolt and washer, install the VMAC main bracket (Figure 5).

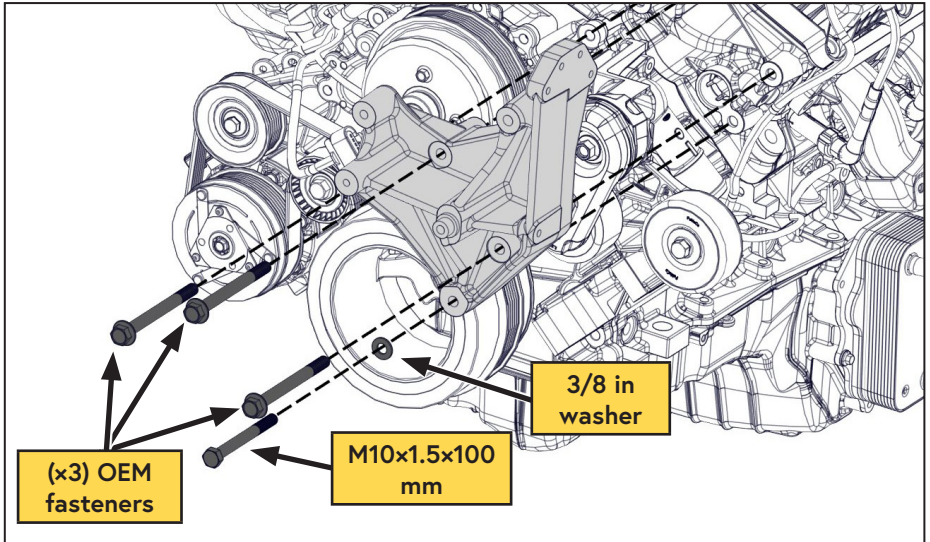

Figure 5 — Install main bracket

- Press the captive nut and bushing on the rear of the alternator back to prevent interference with the bracket (Figure 6).

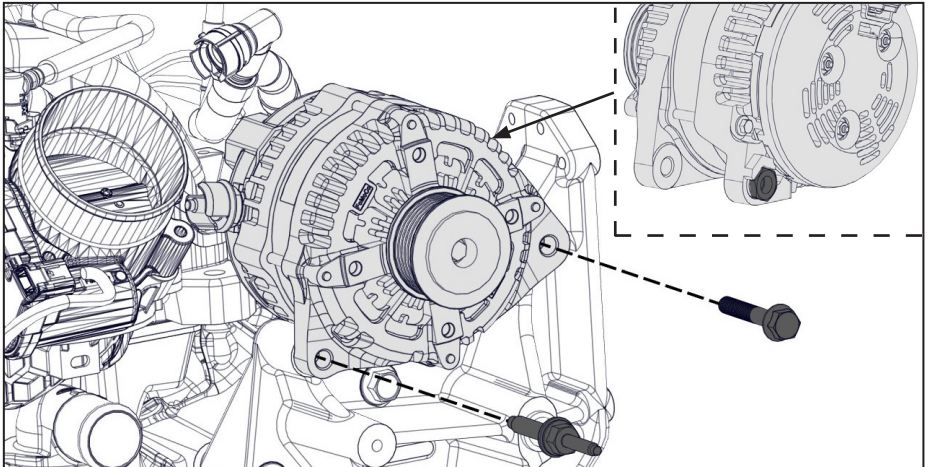

Figure 6 — Install alternator

- Using the OEM fasteners, install the primary alternator onto the main bracket (Figure 6).

- **Dual alternator only:** Using the supplied heat shrink tubing, cover the upper alternator ring terminal (Figure 7).



Figure 7 — Isolate secondary alternator harness

- Install the OEM, and supplied idlers (Figure 8).

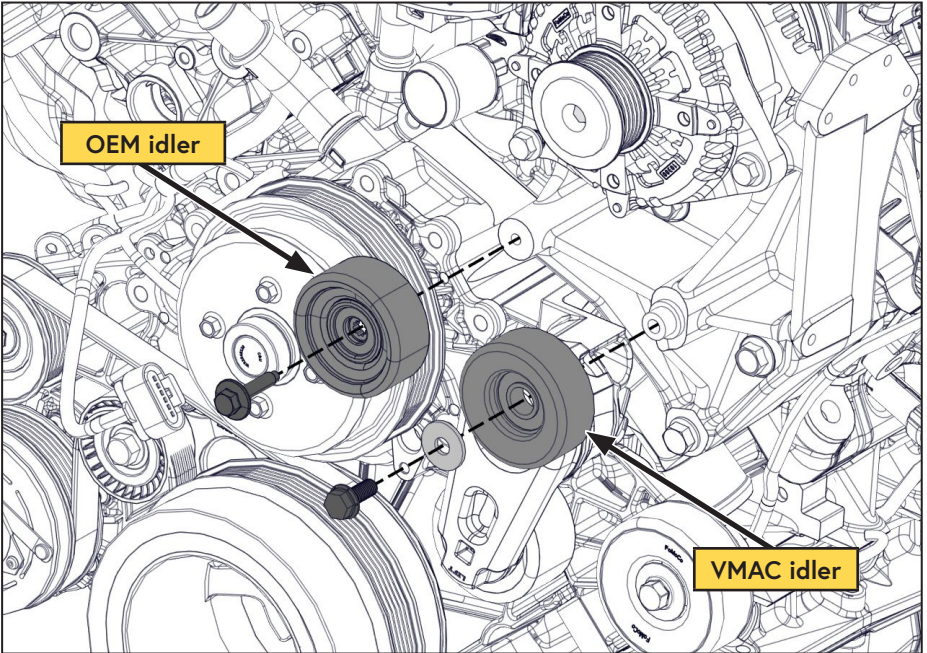
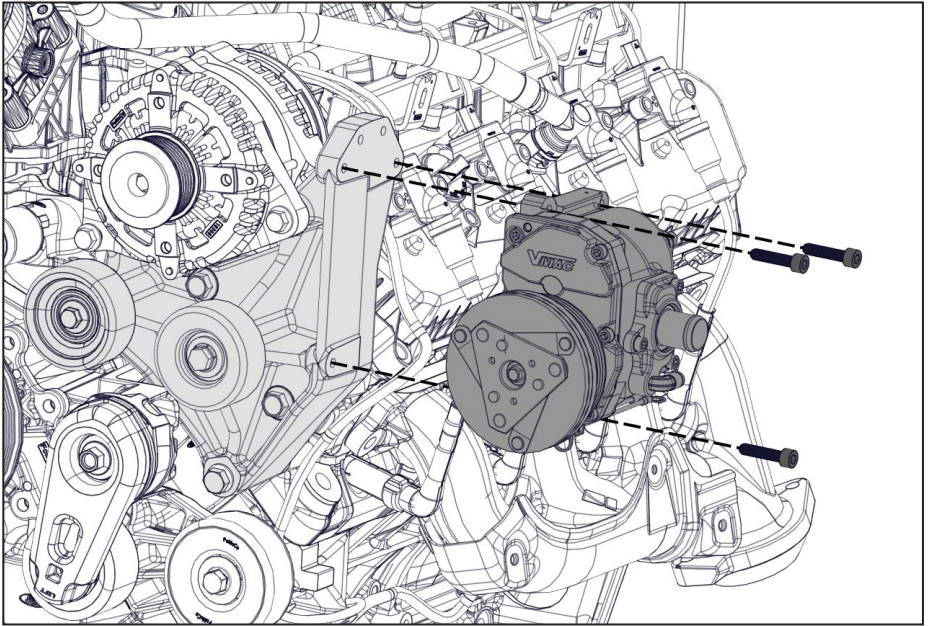

Figure 8 — Install idlers



- Using the supplied fasteners, mount the compressor onto the main bracket (Figure 9).



**Figure 9 — Mount compressor**

- Remove the spark plug wire (nearest the VMAC main bracket) from the ignition solenoid and, using the 3/4 in heat wrap, wrap the wire as close to the end of the boot as possible (Figure 10).



**Figure 10 — Apply heat wrap**

- Apply the 1/2 in heat wrap to the cable, using it to secure the lower portion of the 3/4 in heat wrap (Figure 10).
- Reinstall the spark plug wire.
- Rotate the boot on the primary alternator cable 180°.
- Reconnect the primary alternator cable and wiring clip.

## **VMAC - Vehicle Mounted Air Compressors**

VMAC Technical Support: 888-241-2289

VMAC Knowledge Base: kb.vmacair.com

- Install and tension the VMAC FEAD belt (Figure 11).

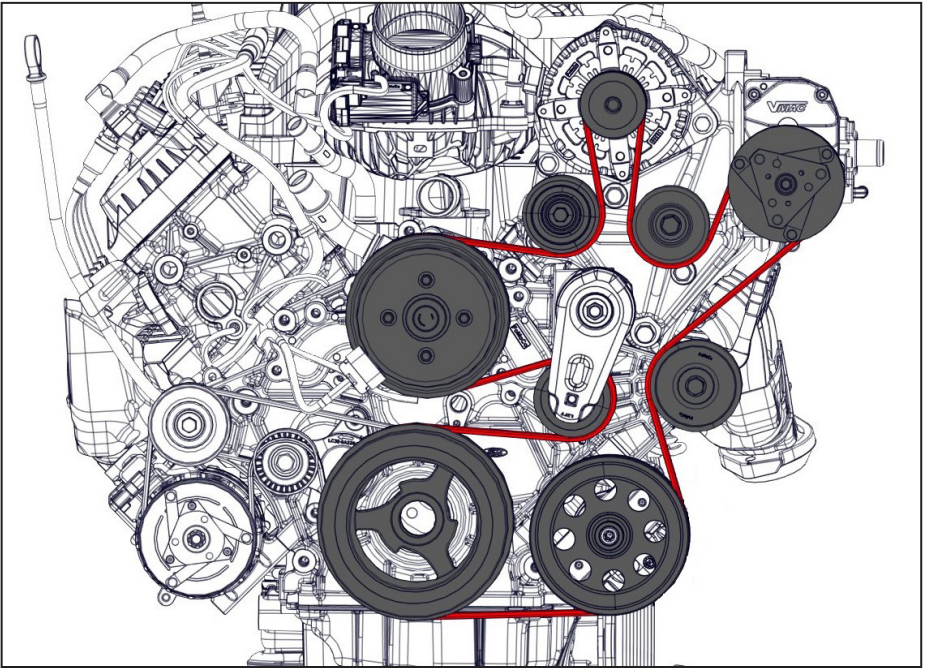

Figure 11 — VMAC FEAD belt routing

- Reinstall fan clutch stator arm.
- Reconnect the fan clutch harness.
- Route the clutch ground wire under the air intake spigot and to the back of the compressor.
- Slide the ring terminal from the clutch ground wire onto one of the supplied fasteners and install the air filter bracket onto the compressor bracket (Figure 12).

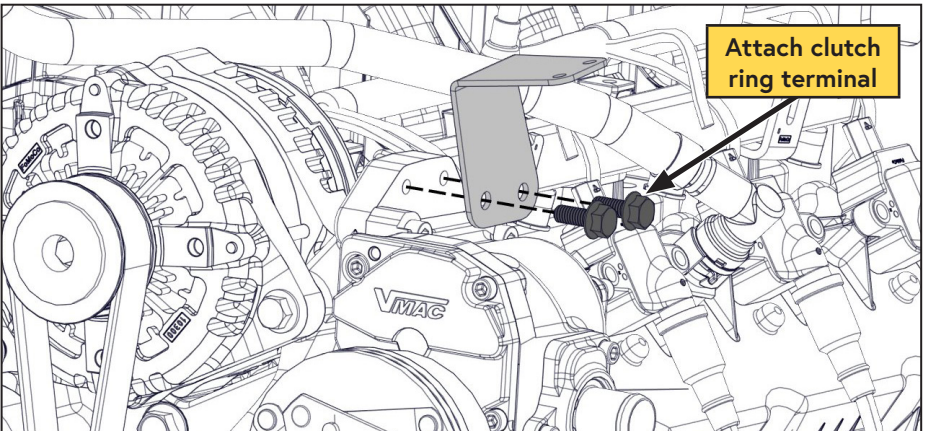
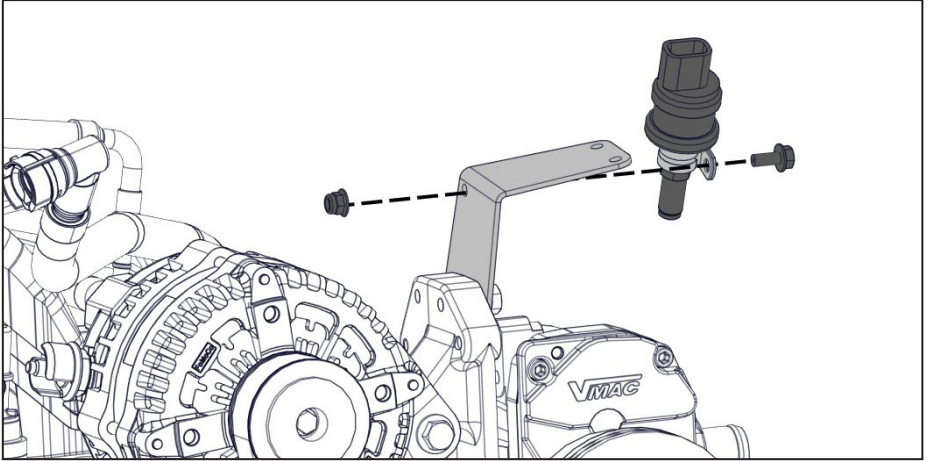

Figure 12 — Install air filter bracket



*To prevent the pooling/accumulation of water in the switch, and subsequent damage from freezing, mount the pressure switch as close to vertical as possible.*

- Using the supplied fasteners and P-clip, mount the pressure switch on the air filter bracket (Figure 13).



**Figure 13 — Mount pressure switch**

- Mount the air filter assembly onto the compressor (Figure 14, Figure 15 on page 16).

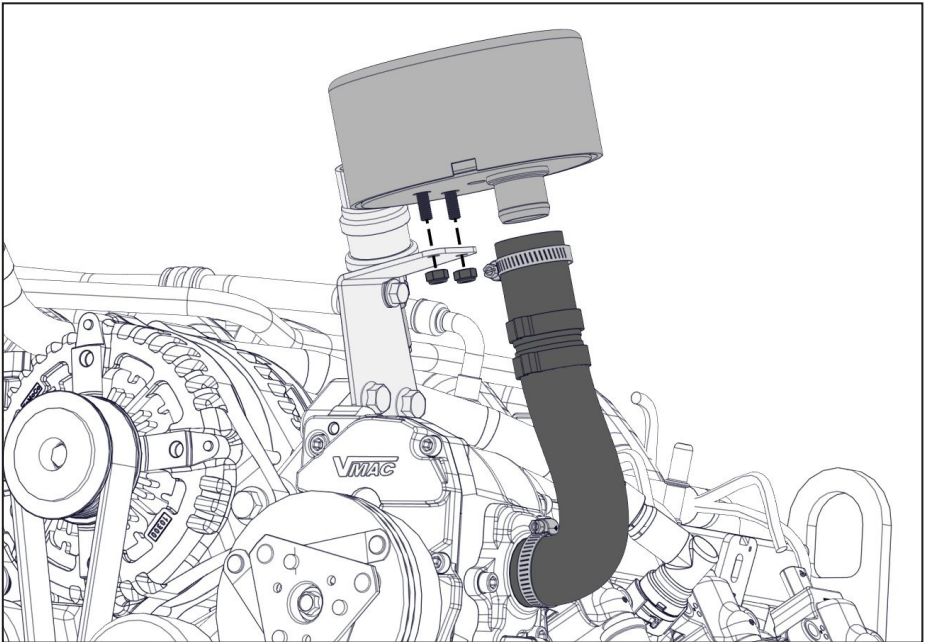

**Figure 14 — Install air filter assembly**



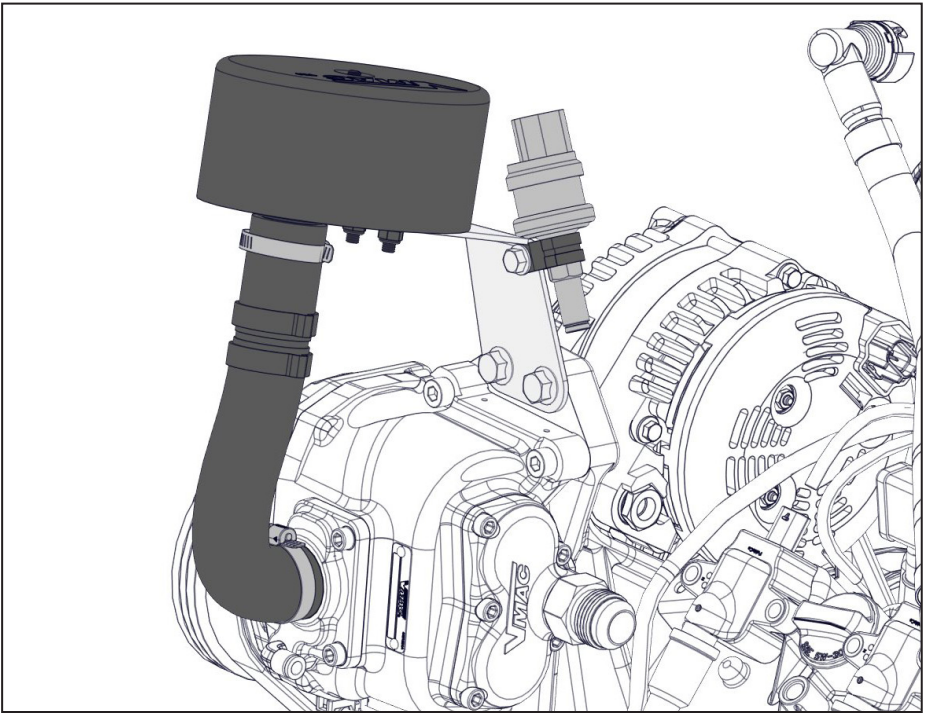

Figure 15 — Pressure switch and air filter assembly

# Installing the Waste Heat Air Separator Package (WHASP) Tank

## WHASP Tank location guidelines



*When determining a mounting location for the WHASP Tank, ensure the following conditions are met:*

- Adequate supply of fresh air and venting for the cooling fan.
- Minimum of 12 in of clearance at the front of the cooling fan.
- Minimum of 6 in clearance at the rear of the unit.
- Hose connections and wiring are accessible.
- Mounted on a level surface.

### **Impact protection.**

- The oil level sight glass is easily accessible.
- The oil fill and drain ports are accessible for servicing.
- Minimize the hose lengths to maximize performance.

## Mounting the WHASP Tank

Refer to (Figure 16) for mounting dimensions.

Special consideration must be made to ensure the WHASP Tank will be protected from damage and to ensure that it has adequate ventilation.

In some cases, it may be necessary to fabricate a mounting bracket to position the tank in an appropriate location.

Secure the WHASP Tank by bolting the mounting feet to the installation surface, use M8 or 5/16 in fasteners (not supplied).

## Mounting in an Enclosure or Body

Mounting the WHASP Tank in an enclosure will limit access to cooling air or restrict the escape of hot air from around the unit and will have an adverse effect on cooling.

Ensure adequate ventilation is provided for the cooling system to function properly. It is not possible to make absolute recommendations regarding ventilation because of the widely differing configurations that are possible. Duty cycle, ambient temperature and enclosure shape are some of the important variables that need to be taken into account when determining the suitability of enclosure mounting.

Cool air ducted to the cooler and installing an exhaust fan to remove hot air is recommended.



*Confirm the hose lengths included in this kit when determining the location of the WHASP Tank and bulkhead fittings. Hose lengths can be found on page 20 or in the IPL. If the WHASP Tank or bulkhead fitting location requires longer hoses, contact a local VMAC dealer. See page 6 for ordering information .*

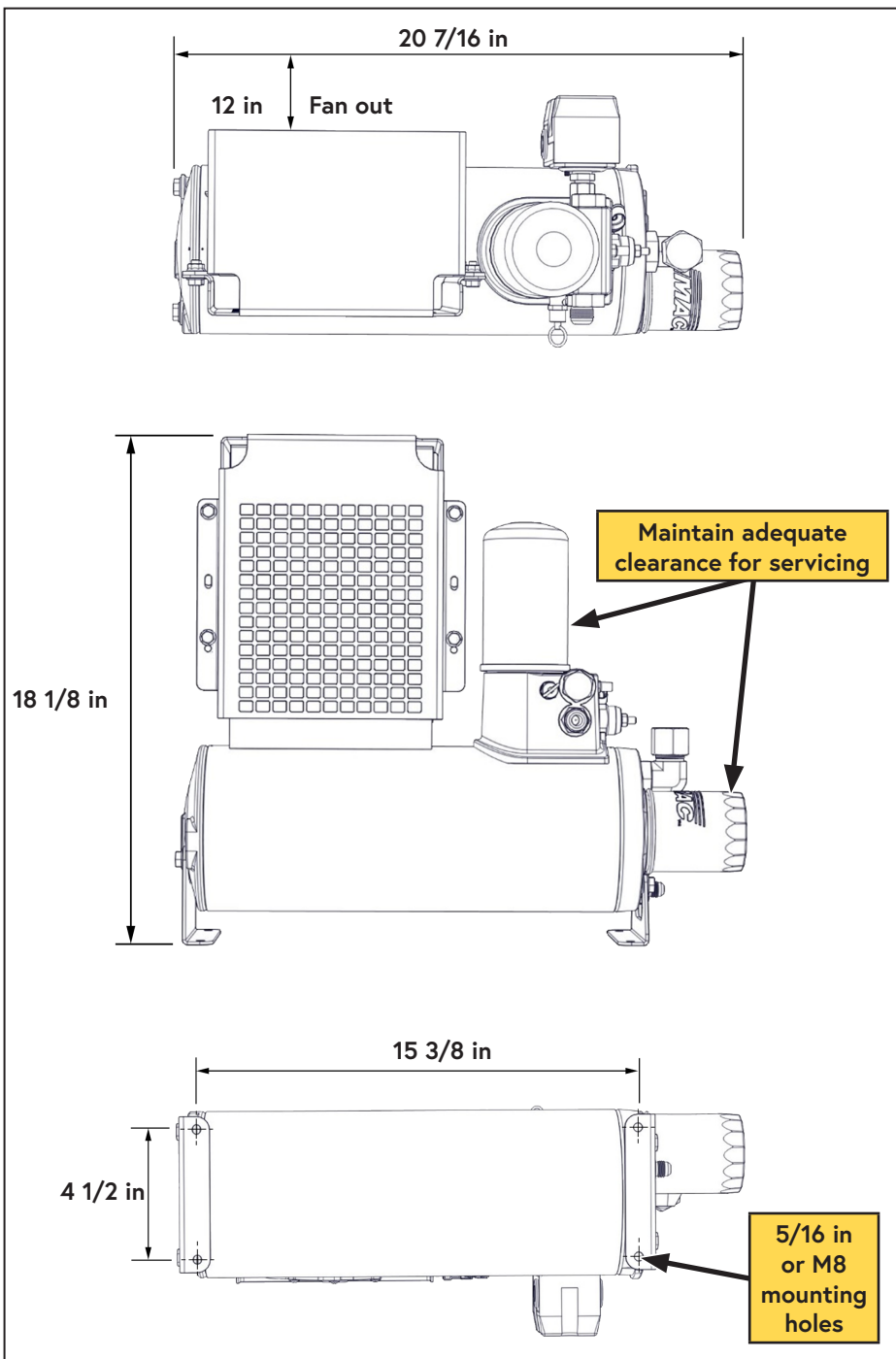

Figure 16 — Minimum WHASP Tank mounting clearances



## Mounting the WHASP Tank

The WHASP Tank uses a "puller" fan to cool the air/oil mixture. Position the WHASP Tank to ensure there is adequate air flow and so that the fan is blowing out toward the cargo door. During operation, the door should be kept open to ensure there is a constant supply of cool air to prevent the system from overheating (Figure 17).



*Provide ample space to check the oil level, as well as access to the filters and compressor oil drain to facilitate servicing.*

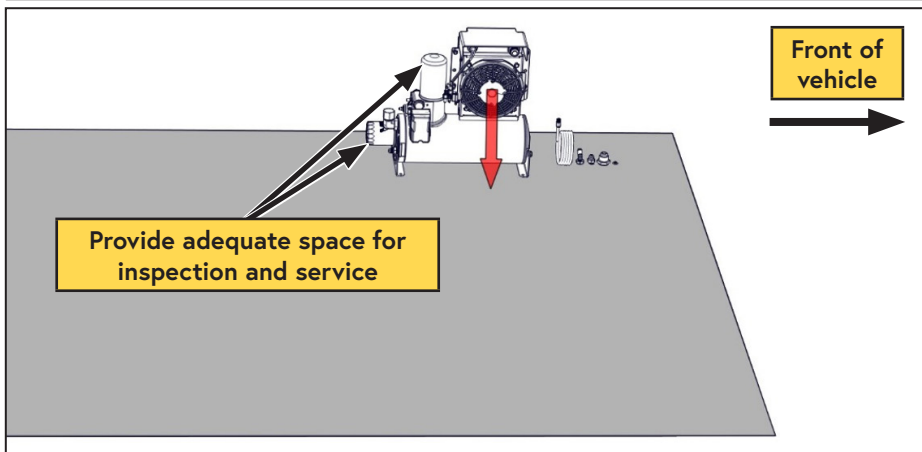

Figure 17 — WHASP ventilation



*A minimum of 6 in of clearance is recommended around the radiator (intake) side of the WHASP Tank to allow fresh, cool air to circulate into the cooler and fan (Figure 18).*

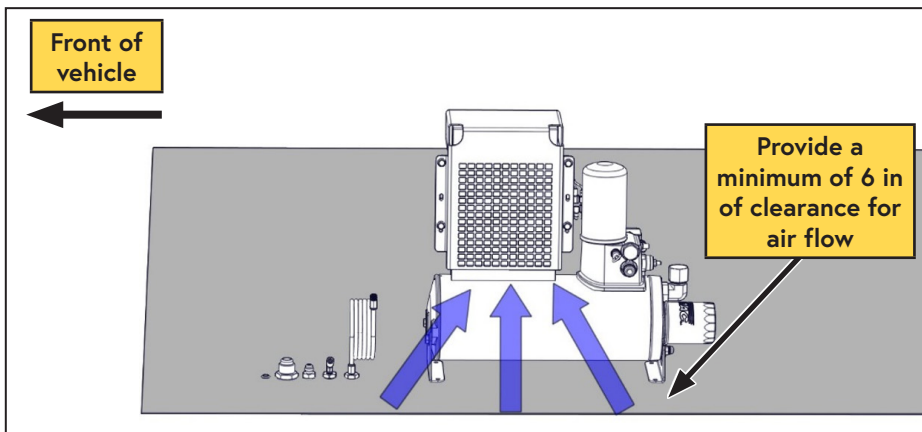

Figure 18 — WHASP ventilation

# Hose Requirements



*Only attempt to shorten the supplied hose if there is access to the appropriate equipment. **Do not** attempt to cut the hose and splice it using hose clamps.*



*VMAC Compressor oil will degrade rubber lined hoses, use only hoses with an AQP elastomer type liner. Contact VMAC Technical Support at 1-888-241-2289 for further information.*

The 1/4 in PTFE tube, and the 3/8 in and 3/4 in hoses with AQP elastomer liner, are specifically designed to work with VMAC compressor oil and at compressor operating temperatures.

Based on the desired location of the WHASP Tank, the hose lengths provided with this system may not be ideal. They can be shortened or replaced as necessary, or hose extenders can be used.

VMAC recommends shortening these hoses as a preferred alternative to coiling up and securing the excess.

***Shorter hose length will maximize system performance.***



*Avoid using 90° fittings wherever possible as they cause flow restrictions and negatively impact performance.*

**The following hoses are included with this compressor kit:**

- 3/4 in × 170 in.
- 3/8 in × 170 in.
- 1/4 in (PTFE Tube) × 180 in.
- 1/4 in (PTFE Tube) × 24 in.

## **If longer hoses are required:**

To order parts, contact a VMAC dealer. The dealer will ask for the VMAC serial number, part number, description and quantity. See page 6 for ordering information.

- Eaton Aeroquip hoses with an "AQP" type inner liner are required.
- OTC fittings are required for the VMAC supplied hose.
- Push-lock fittings are suitable if FC332 hose is used.
- If Push-lock fittings are being used, do not use hose clamps as they will damage the hose and cause leaks.

# Connecting the Hoses



*When routing hoses, ensure cap plugs are installed so that contaminants do not get in the line. Take care when routing hoses, as a hose failure may damage the compressor and/or cause injury.*



*All hoses, tubes and wires that are installed, rerouted or shifted during the installation must be secured so that they do not contact any hot, sharp or moving parts. Use rubber coated P-clips wherever possible. Follow the routing suggestions in this manual and cover all hoses with plastic loom.*



*Ensure there is sufficient slack in the hose routing to allow for normal engine movement.*

## PTFE Tubing, Loom, and Push-To-Connect Fittings

- PTFE tubing should only be cut using proper tubing cutters. Side cutters, utility knives, etc. will deform the tube, preventing a proper seal (or leave sharp edges which cut the internal O-ring).
- When applying loom to the PTFE tube, leave approximately 1 in between the loom and the fitting.
- Ensure the tube is clean, cut at 90° and that there are not sharp edges.
- Lubricate the tube and firmly push it into the fitting so that the tube fully seats in the fitting.
- Slide the collet out, away from the body of the fitting to lock the tubing in place.
- Ensure the tube does not have any "play" to prevent the O-ring from wearing.

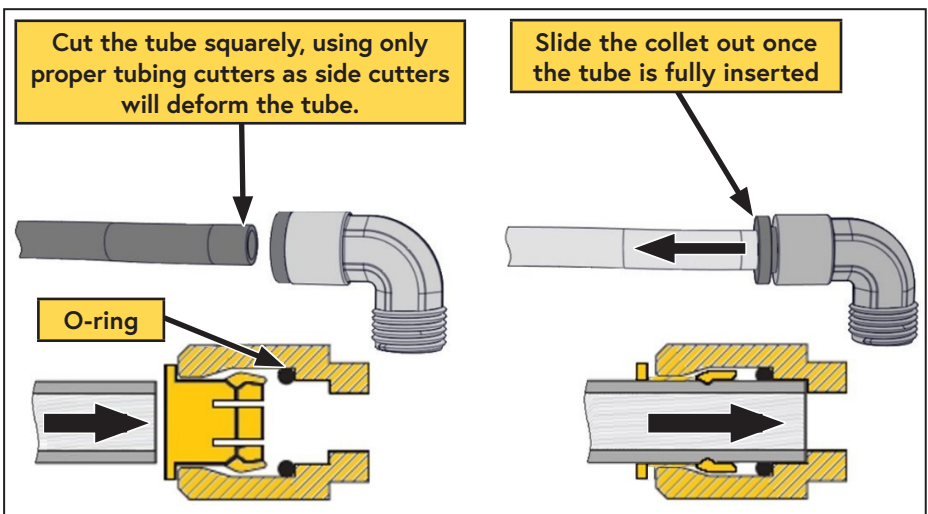
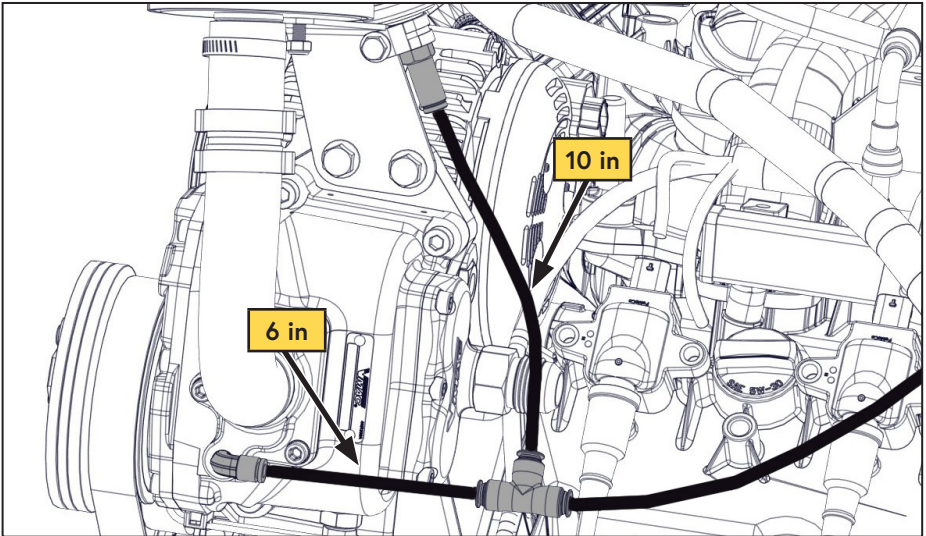

Figure 19 — Push-to-connect fittings

- Apply the supplied high temperature split loom to the 1/4 in PTFE tube.
- Connect the 45° fitting on the 3/4 in hose to the compressor.
- Connect the straight fitting on the 3/8 in hose to the compressor.
- Cut a 6 in length, and a 10 in length from the 24 in spool of 1/4 in PTFE tubing.
- Connect the 1/4 in PTFE scavenge tubes between the compressor, pressure switch, and Tee union (Figure 20).



**Figure 20 — Connect PTFE tubes**

- Cut the 20 in length of loom as necessary and apply it to the scavenge and pressure switch tubing.
- Route the 3/4 in hose toward the firewall and up, over the engine to the passenger side of the vehicle (Figure 21).

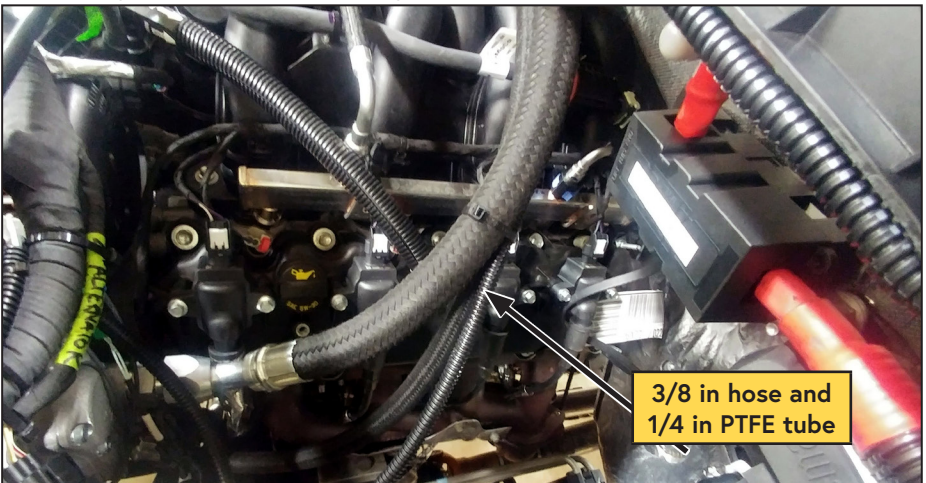

**Figure 21 — Route hoses**



- Route the 3/8 in hose and 1/4 in PTFE tube toward the firewall, following the same route as the 3/4 in hose. Using the supplied cable ties, secure the hose and tube bundle to the 3/4 in hose (Figure 21).
- Using the supplied P-clip and lock nut, secure the 3/4 in hose to the stud in the firewall (Figure 22).



Figure 22 — Route hoses

- Route the hose bundle down between the frame and the fender liner, toward the rear of the vehicle (Figure 23).

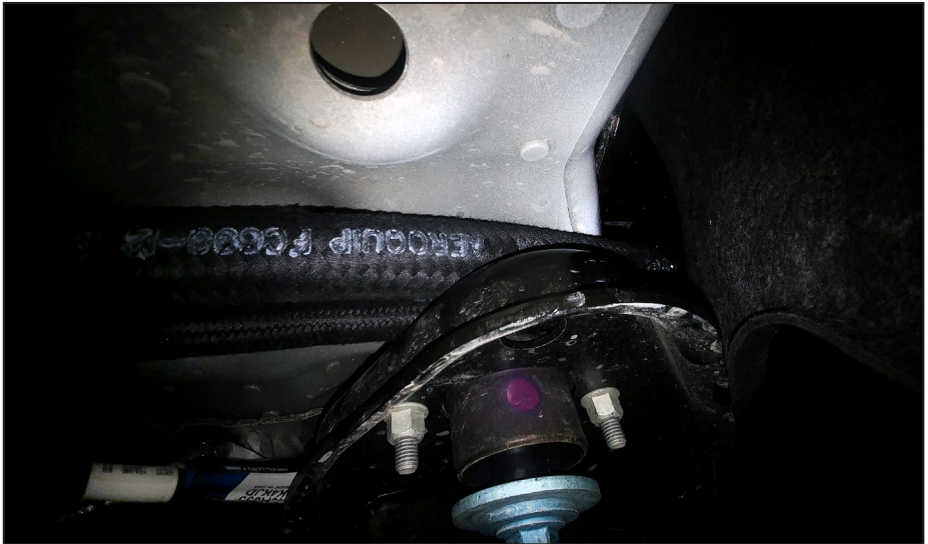

Figure 23 — Route hoses

- Using the inner running board fasteners, install the supplied P-clip brackets. Use (x2) brackets for regular cab, (x3) brackets for extended / crew cabs.
- Using the supplied P-clip and fasteners, secure the 3/4 in hose to the P-clip brackets (Figure 24, Figure 25).



Figure 24 — Route hoses



Figure 25 — Route hoses

- Using the supplied cable ties, secure the 3/8 in hose and PTFE tube to the 3/4 in hose (Figure 25).

- Determine a suitable routing path for the hoses running from the compressor to the WHASP tank; avoid hot, sharp or moving components.



**Ensure there is sufficient slack in the hose routing to allow for normal body/frame movement.**

- Bundle the 1/4 in PTFE tube, the 3/4 in, and the 3/8 in hoses and route them to the WHASP Tank.
- Connect the straight fitting on the 3/4 in hose to the #12 JIC fitting (air/oil inlet) on the cooler above the fan (Figure 26).

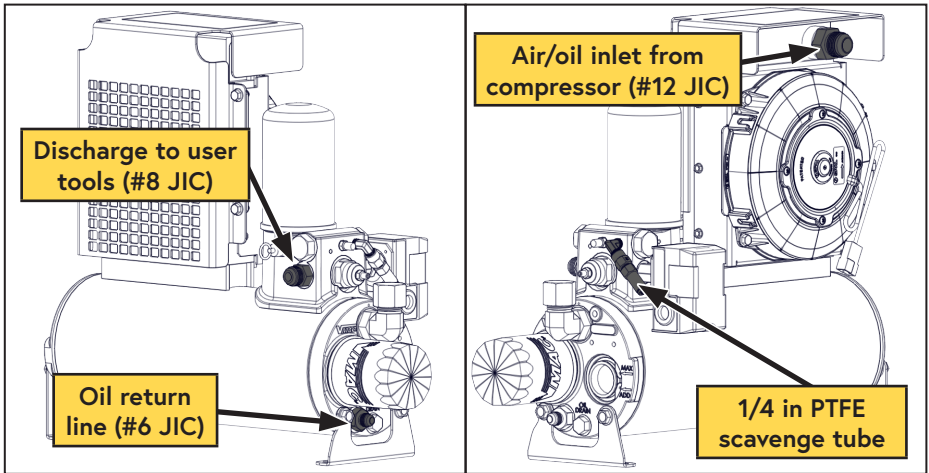

**Figure 26 — WHASP Tank connections**

- Connect the 90° fitting on the 3/8 in hose to the #6 JIC fitting (oil return fitting) beneath the oil filter on the tank (Figure 26).
- Connect the 1/4 in PTFE tube to the 1/4 in push-to-connect (oil scavenge) fitting near the coalescing filter (Figure 26).
- Connect the discharge fitting (#8 male JIC) to the customer's air system (hose not supplied).
- Secure all hoses, tubes, and wires with P-clips and/or cable ties.



**Use of an air receiver tank (minimum 6 USG) is required with this application.**

**Follow the instructions on page 40 of this manual to prevent damage to the system.**

# Adding Oil to the System



*The VMAC supplied and approved compressor oil must be used in this system. Failure to use this special oil will result in damage to the compressor and will void warranty.*

*Do not overfill the system. Overfilling the system with oil can flood the sight glass window and make the system appear empty.*

- Remove the fill cap on the WHASP Tank (above the sight glass) (Figure 27).
- Using a funnel, pour oil into the tank until the oil level in the sight glass reaches the "MAX" line. **The system capacity is 4 L** (Figure 27).
- Reinstall the fill cap and tighten it securely. Ensure the fill port remains accessible as it will be necessary to check and top up the oil after the first compressor start.

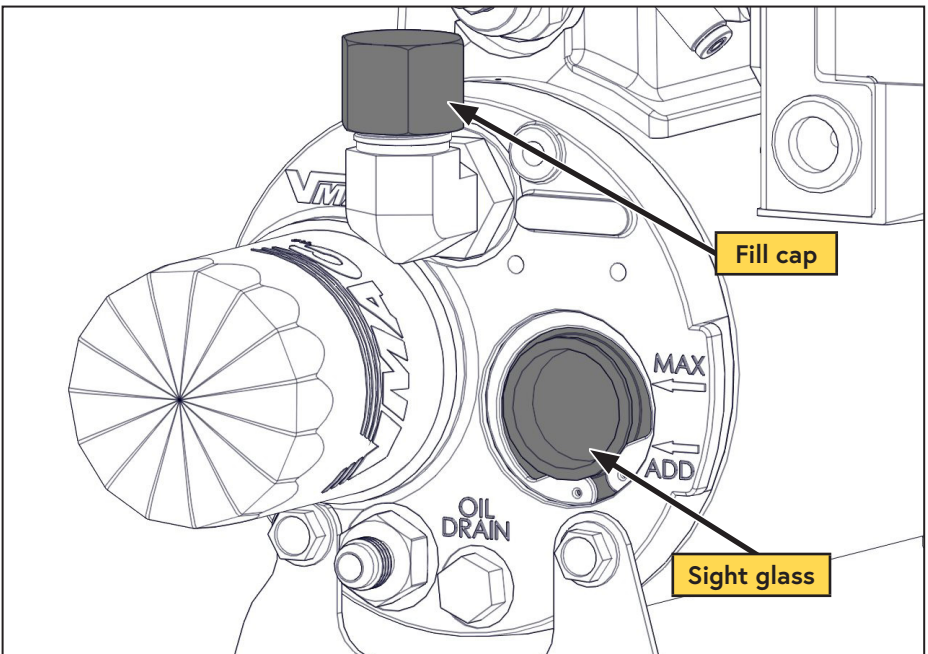

Figure 27 — Filling the WHASP Tank



# Installing the Control System

## Best Practices

- To confirm a good ground, use an ohm meter to measure the resistance between the ground point and the negative battery terminal. Resistance should be less than 1  $\Omega$ .
- Route all wires to ensure they will not contact hot, sharp or moving parts (including the park brake mechanism, steering column, and pedals).
- Before drilling any holes ensure there are no OEM wires, hoses, or components that may be damaged.
- Do not use a test light to probe for power on vehicle circuits, the increased current draw of the test light may damage components.
- VMAC recommends using only sealed crimp and solder butt connectors for all electrical connections.
- To ensure a durable connection, use only good quality crimping tools.
- Apply loom to all wiring:
  - Use high temperature loom in areas where high temperatures may be expected.
  - Use spiral loom in areas with high vibration.

## In-line Butt Splice Connections

- Cut the wire approximately 2 in from the connector.
- Strip approximately 3/8 in from the end of both sides of the cut wire, as well as from the end of the wire being spliced in-line.
- Twist the wire to be spliced in-line, together with the "live" side of the wire (not the wire attached to the connector).
- Slide the butt connector onto the twisted wires and crimp it.
- Insert the "connector side" of the wire into butt connector and crimp it.
- Lightly tug the wires to ensure they are properly crimped.
- Using a heat gun, carefully apply heat to the butt connectors to seal the connection.

## Posi-Tap Connectors

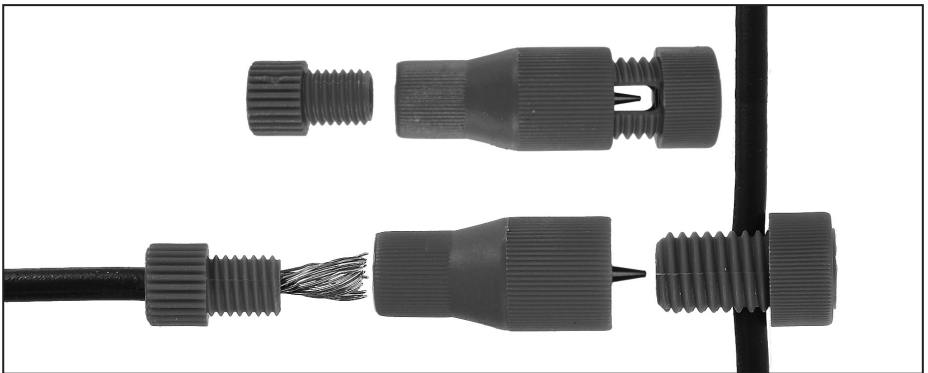

Figure 28 — Posi-Tap wire connector

- Slide the OEM (live) wire into the slot on the large cap as far as it will go.
- Thread the tap (barrel with pin) over the slotted cap, ensuring the pin is centered on the wire. Firmly tighten the tap.
- Strip approximately 3/8 in from the end of wire.
- Unscrew the small cap.
- Twist the wires together and insert the wire into the cap.
- Deflect the wires to one side.
- Insert the cap into the tap, ensuring the wires enter one side of the metal core.
- Ensuring the wire does not slip out of the cap, push and turn until the threads catch and firmly tighten the cap.
- Ensure all of the connections are firmly tightened by hand (overtightening will cause the threads to strip).

## **Tying into OEM connectors**

Some OEM connectors may have locking tabs that must be disengaged prior to inserting a crimped connector.

## Electrical Modules

- The throttle control, control module, and interface panel are not weather proof; ensure they are mounted where they will be protected from rain, snow, mud, direct sunlight, etc. (e.g. inside the cab, service body or cabinet).
- Keep the rear of the interface panel protected.
- Ensure the control module and throttle control are mounted away from the pedals, park brake mechanism, or where they could be inadvertently knocked by occupants.

## Control Components Overview

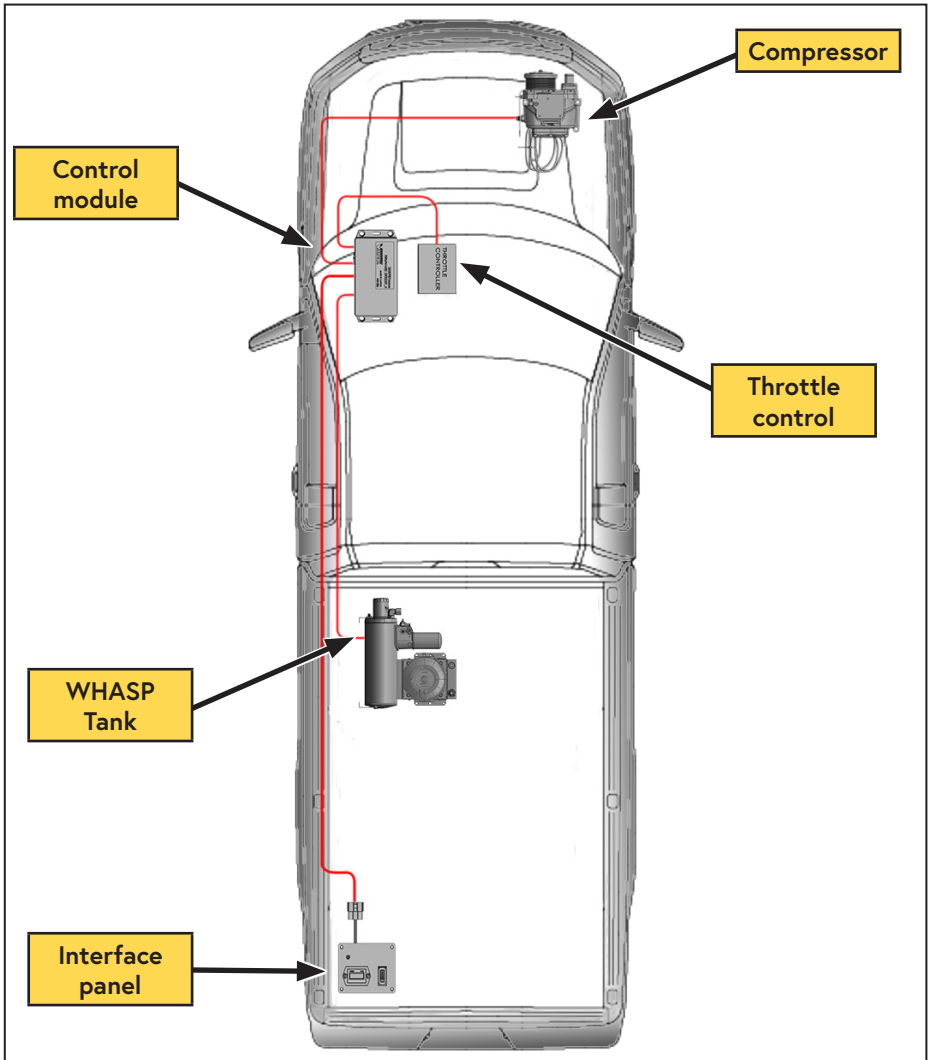

Figure 29 — General component overview  
(Actual installation locations may vary)

### Control Module (Figure 30)

The control module serves as the primary input/output interface between the vehicle and the various VMAC components (compressor, throttle control, WHASP Tank, interface panel, etc.).

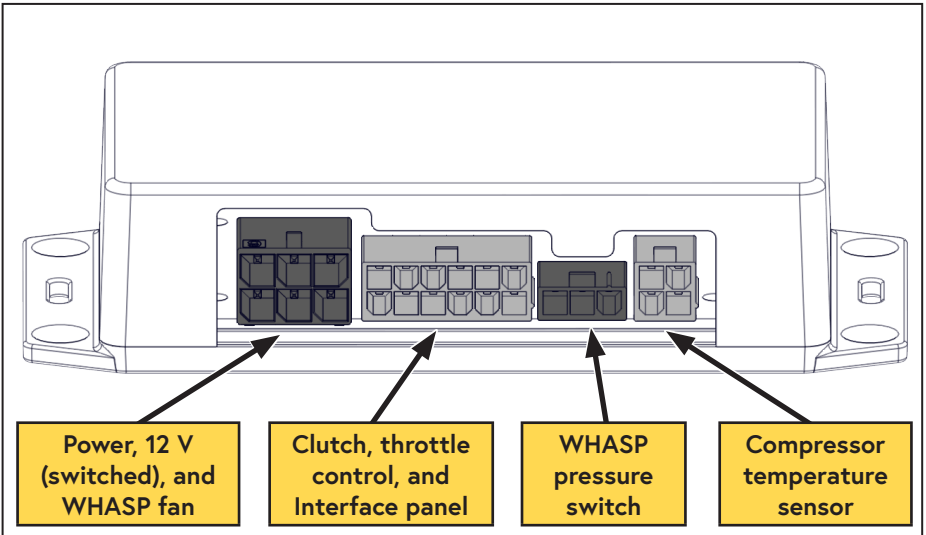

Figure 30 — Control module

### Interface Panel (Figure 31)

The interface panel serves as the operator's control panel and contains the "ON/OFF" switch, compressor status light, and the compressor hour meter.

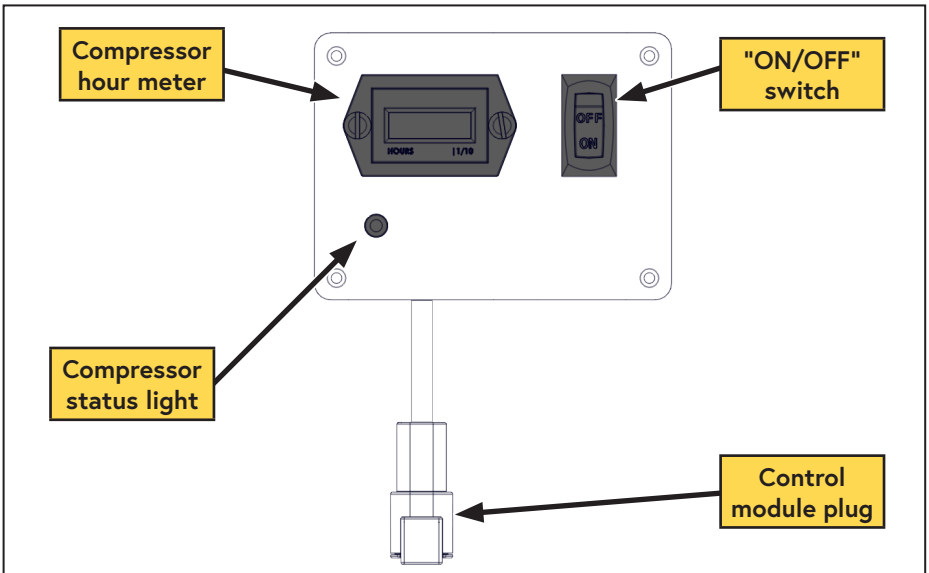

Figure 31 — Interface panel

### Throttle Control (DTC) (Figure 32)

The throttle control responds to signals from the control module and commands the vehicle's throttle to increase or decrease engine speed in response to air demand. The throttle control also allows the operator to configure the vehicle's engine speed (when air is demanded) to their needs (maximum cfm, specific tool requirements, fuel efficiency, or a combination of these factors).

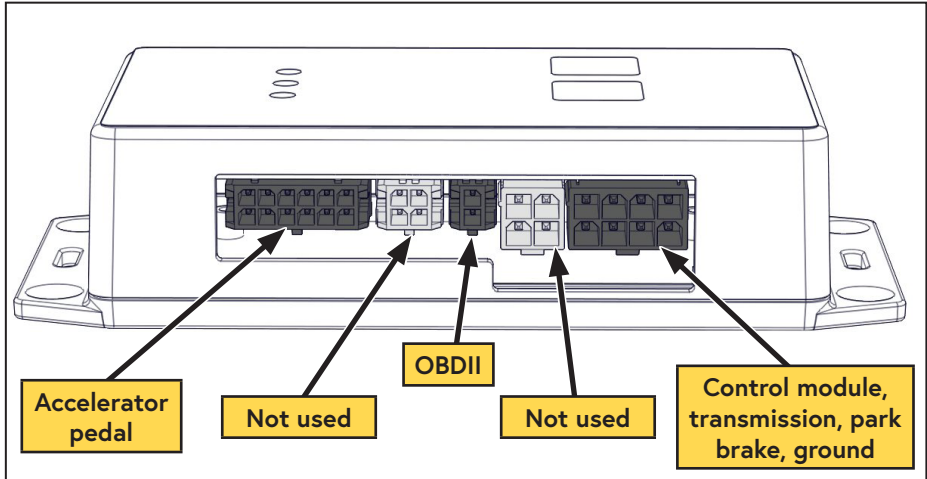

Figure 32 — VMAC digital throttle control

### Mechanical Pressure Switch (Figure 33)

The mechanical pressure switch is mounted on the side of the WHASP Tank and limits the maximum pressure to a safe amount by disengaging the clutch once system pressure is achieved.

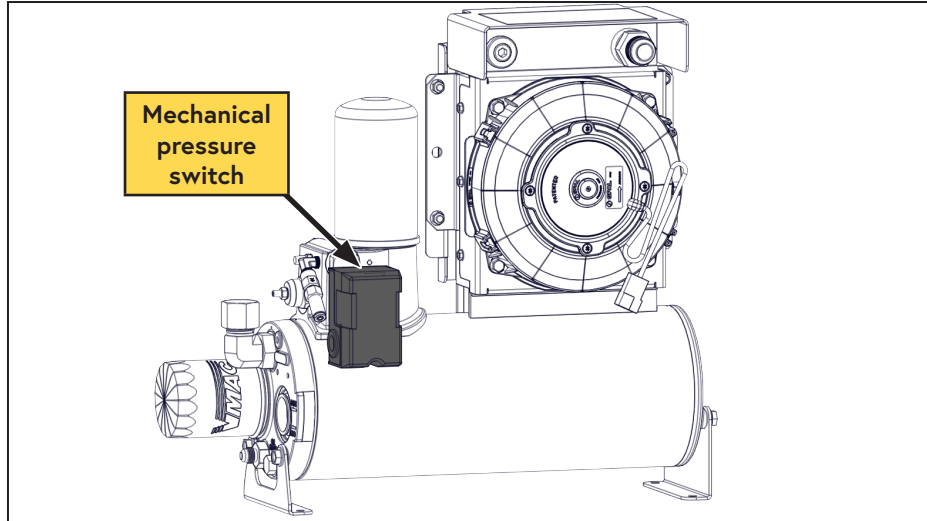

Figure 33 — WHASP Tank pressure switch

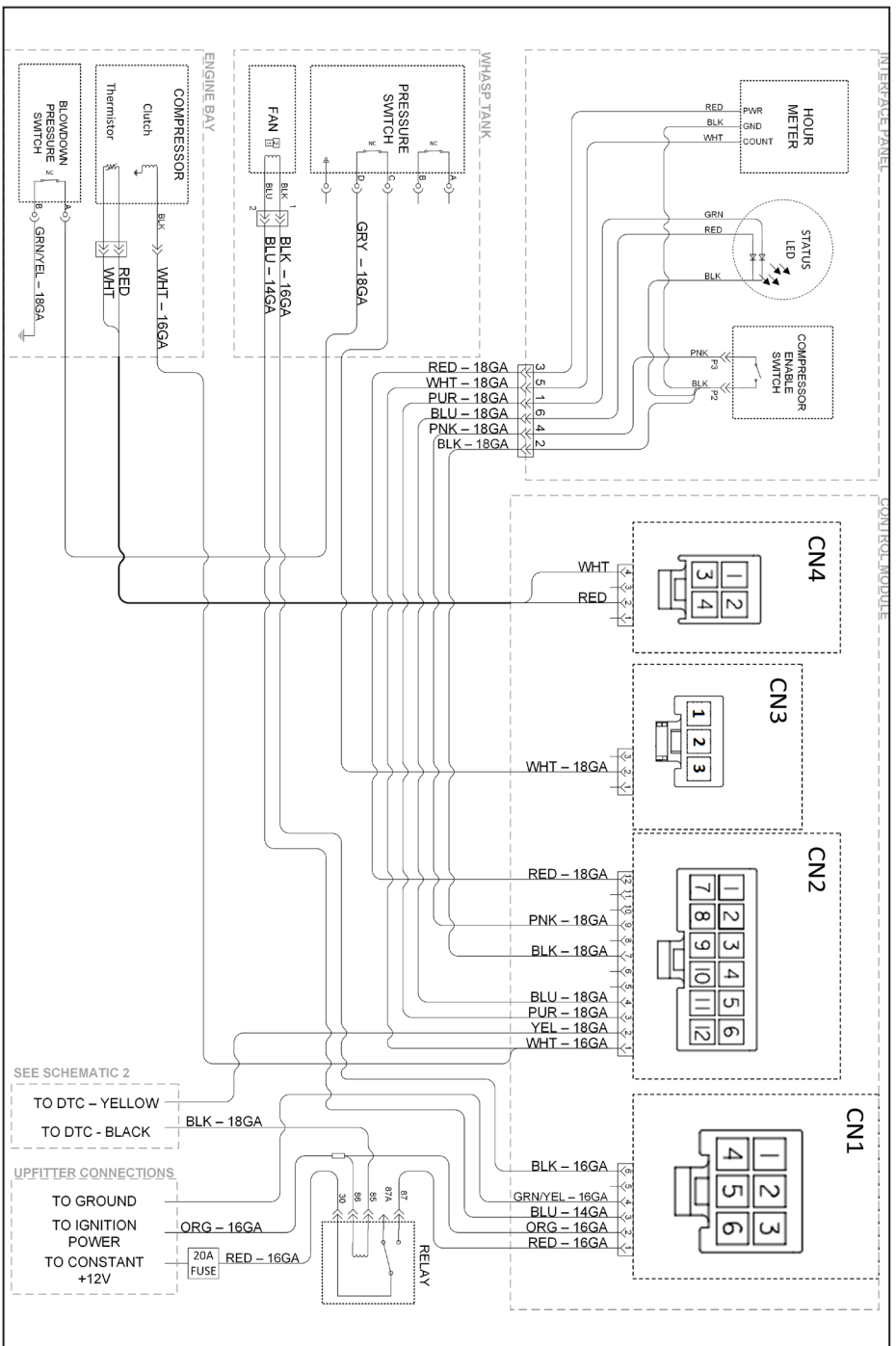

Figure 34 — Electrical schematic 1

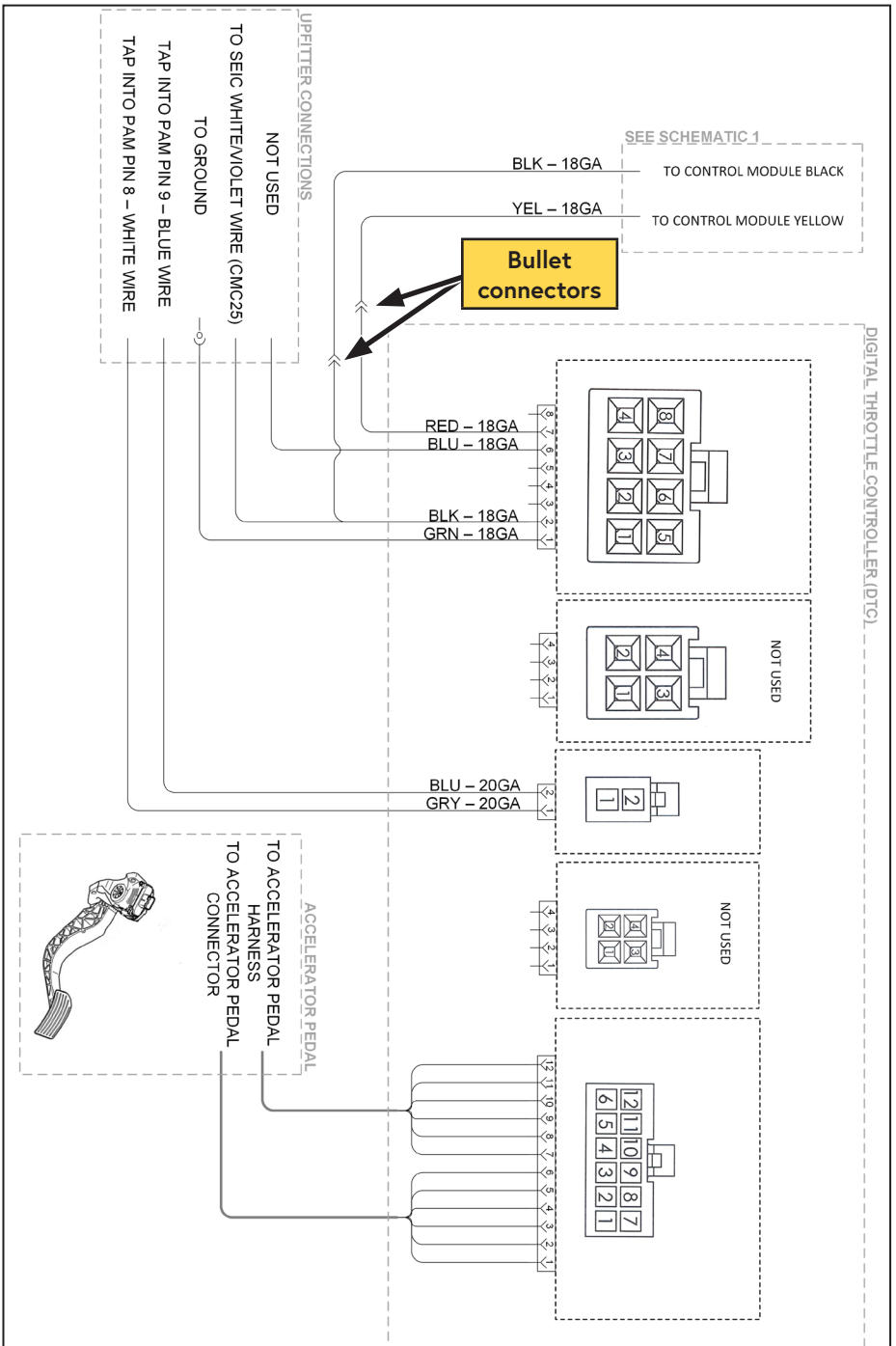

Figure 35 — Electrical schematic 2

## Control Module

- Plug the 4 harnesses into the control module.
- Mount the control module under the dashboard, up and out of the way of the pedals, steering column, and the park brake mechanism.
- Mount the control module power harness relay near the control module.
- Connect the ground wire (green wire with yellow stripe) running from the control module to a good ground.

## Throttle Control

- Using cable ties, secure the throttle control under the dashboard, next to the OBD II port. Ensure it is away from moving parts and positioned so that the buttons and LED lights are accessible.

## Connecting the Wiring

- Unplug the OEM cable from the accelerator pedal and plug it into the matching connector from the throttle control. Plug the cable from the throttle control into the matching connector on the accelerator pedal.
- Connect the ground wire (green wire) running from the throttle control to a good ground.
- Connect the bullet connector on the yellow wire running from the control box to the matching connector on the throttle control.
- Locate the Parking Assist Control Module (PAM) (located on the driver side, under the dashboard and above the parking brake). The PAM harness will either be plugged into a blanking plug, or a PAM module (Figure 36).

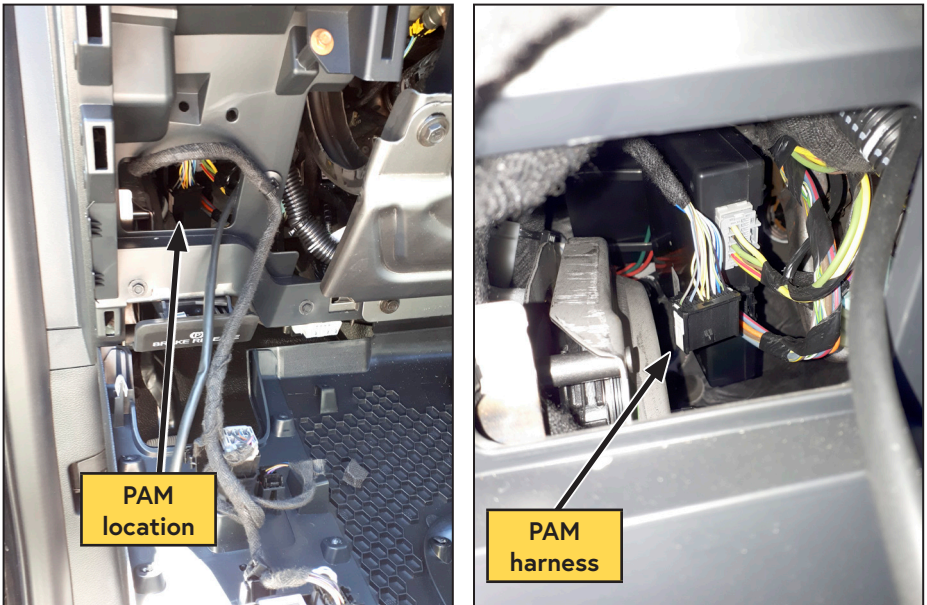

Figure 36 — Parking Assist Control Module (PAM)



- Disconnect the connector.



***Due to running OEM changes, the PAM wire colours are subject to change without notice however, pins 8 (CAN low) and 9 (CAN high) of the PAM connector shall be the definitive method for determining the correct wire connections.***

***Pins 8 and 9 will have 2 wires of the same colour crimped to their respective pins, either wire may be utilized for the connections.***

- Using the supplied Posi-Taps (see page 27), connect the blue wire from the throttle control to the wire at pin 9 (blue wire at time of writing) of the PAM connector (Figure 37).

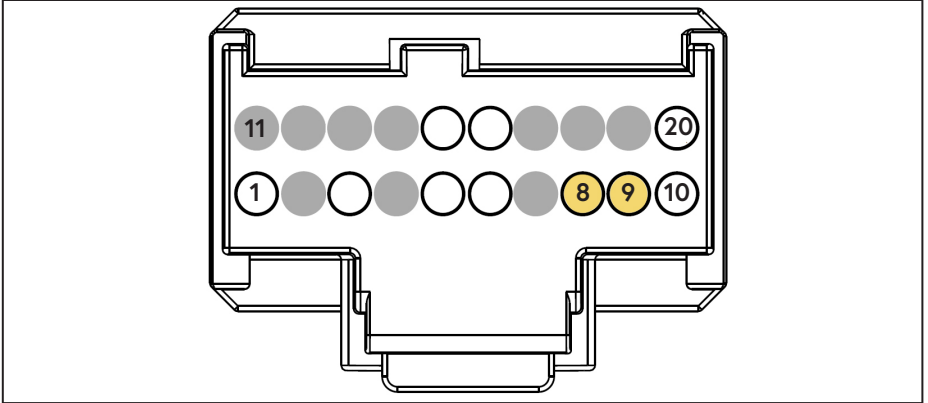

**Figure 37 — PAM connector**

- Using the supplied Posi-Taps, connect the grey wire from the throttle control to the wire at pin 8 (white wire at time of writing) of the PAM connector (Figure 37)
- Reconnect the PAM harness to the PAM module or blanking plug.
- Shorten the darker blue wire running from the throttle control and apply insulation (e.g. shrink tube, electrical tape, etc.) to safely terminate the wire.
- Splice the orange wire from the power harness on the control module to the green wire with orange stripe at pin 2 (IGN switched 12 V CBP22) of the SEIC pigtail.
- Splice the black wire running from the throttle control to the white wire with violet stripe (CMC25).

Route the following wires into the engine compartment via a grommet in the firewall\*:

- \*White 16 AWG wire with bullet connector from the control module (clutch wire).
- \*Grey cable with the green connector from the control module (temperature sensor).
- \*Red wire from the control module (constant power). Cover all of the engine compartment wires with plastic loom. Unplug the SEIC pigtail from the SEIC interface plug.

## Engine Bay Connections

- Route the grey cable and white wire running from the control module along the OEM wiring harness, and around the degas bottle.
- Crimp the supplied fuse holder to the red wire running from the control module. Ensure the fuse holder is installed as close to the power source as possible.
- Connect the other end of the fuse holder to the positive battery terminal.
- Connect the green connector on the grey cable to the matching connector on the compressor.
- Connect the bullet connector on the white wire to the matching connector on the compressor.
- Connect the 2 pin connector on the pressure switch harness into the pressure switch.
- Connect the ring terminal on the green wire with yellow stripe to a good ground.
- Route the grey 18 AWG wire to the WHASP Tank.

## Interface Panel

- Install the interface panel in a suitable location (Figure 38).

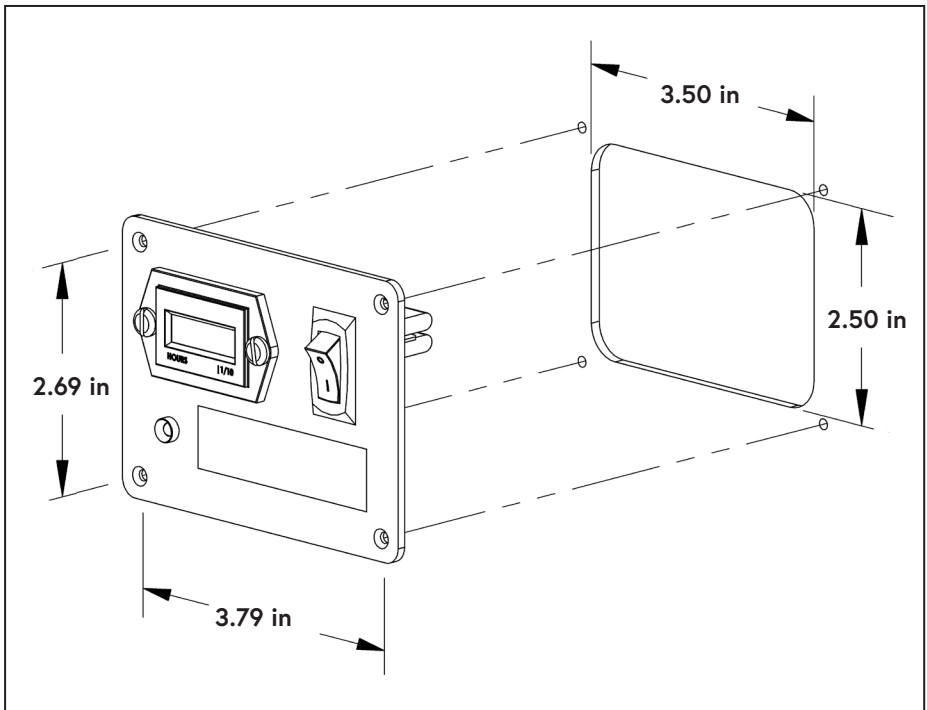

Figure 38 — Interface panel mounting dimensions

- Connect the harness from the control module to the interface panel.
- Connect the fan connector from the control module to the plug on the WHASP Tank.
- Remove the cover from the WHASP Tank pressure switch.

- Connect the ring terminals from the white wire running from the control module, and the grey wire running from the pressure switch (at the compressor), to the pressure switch on the WHASP Tank (these are not polarity dependent) (Figure 39).

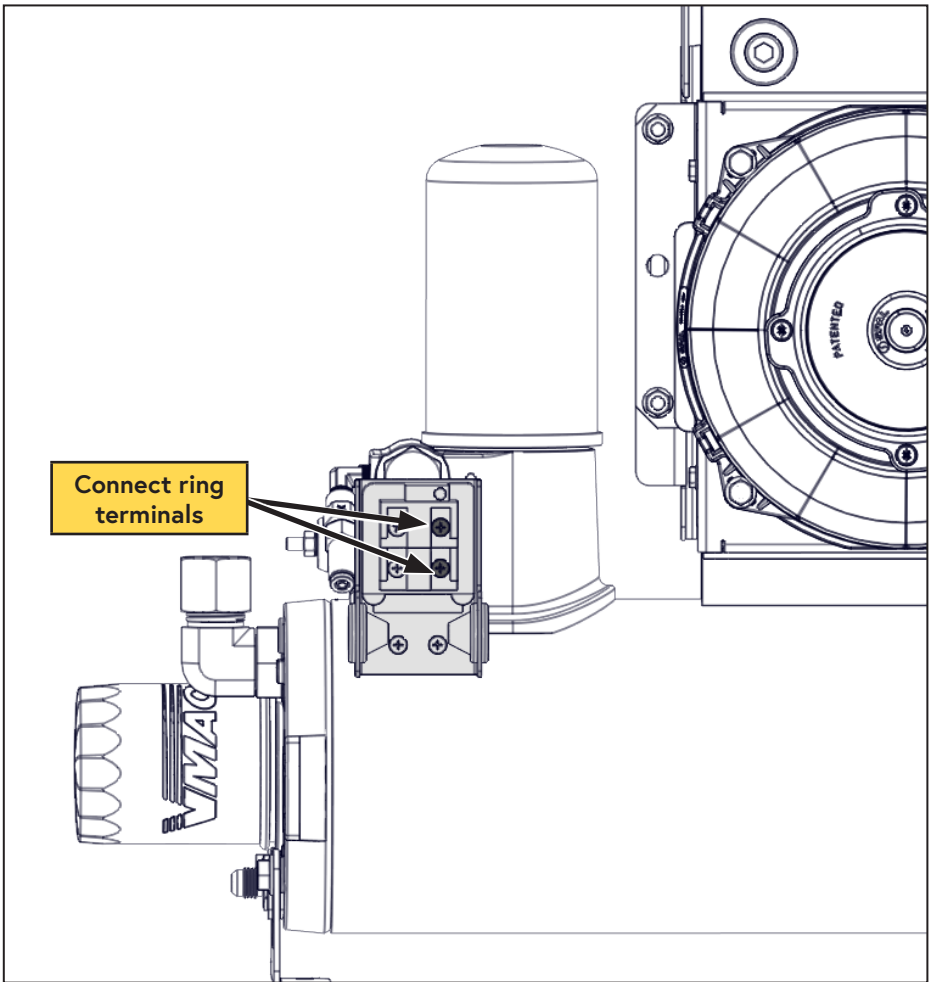

Figure 39 — Connect pressure switch

- Replace the WHASP Tank pressure switch cover.



*The WHASP Tank harnesses are made to a generic length. Any excess harness should be coiled up and secured out of the way. There are 2 extra ring terminals included with the pressure switch harness; if desired, cut the harness to length and crimp the spare ring connectors to it.*

- Ensure all wires and harnesses are protected with loom and routed away from sharp, hot, or moving components and away from high traffic areas.

# Completing the Installation

- Check all VMAC and OEM wiring to ensure it will not contact any hot, sharp or moving components and will not interfere with the operation of the vehicle. Secure all wiring with rubber coated P-clips, cable ties and loom as required.
- Check all VMAC and OEM hoses and tubes to ensure they will not contact any hot, sharp or moving components and will not interfere with the operation of the vehicle. Secure all hoses and tubes with rubber coated P-clips, cable ties and loom as required.
- Reinstall the intake tube.
- Reinstall the power steering reservoir.
- Replace all dashboard panels and kick plates that were removed.
- Reconnect the battery(s).
- Affix the safety and operational instruction decal in an obvious location so that it can be seen by vehicle operators. A good spot for this is usually on the inside of the door or on the panel underneath the steering wheel (Figure 40).



Figure 40 — Advisory label



*The VMAC warranty form must be completed and returned to VMAC at the time of installation for any subsequent warranty claim to be considered valid.*

- Complete the warranty form. The VMAC warranty form is located at the back of this manual, as well as online at: [www.vmacair.com/warranty](http://www.vmacair.com/warranty)



- Affix the safety and operational instruction decal in an obvious location so that it can be seen by vehicle operators. A good spot for this is usually on the inside of the door or on the panel underneath the steering wheel (Figure 41).

**VMAC**  
VEHICLE MOUNTED AIR COMPRESSORS

This vehicle is equipped with a  
VMAC Air Compressor System.

**OPERATING INSTRUCTIONS**

**Daily Pre Start Check:**

1. Check oil level in tank.
2. Check drive belt system.
3. Check for leaks.

**Start Up Procedure:**

1. Ensure air system is depressurized.
2. Ensure all air outlets are CLOSED.
3. Place vehicle in Neutral or Park and engage park brake.
4. Start engine and bring to operating temperature.
5. Turn ON compressor.

**Shutdown Procedure:**

1. Ensure discharge valve is CLOSED.
2. Allow engine to idle for 1 minute.
3. Turn OFF compressor.
4. Wait for system to depressurize before restarting.

For Technical Support/Parts contact your VMAC Dealer  
To locate your nearest dealer call 1-800-738-8622 (250-740-3200)

4400644-A

**WARNING**  
Always allow system to  
depressurize before restarting

Figure 41 — Operating Instruction label

- Install the VMAC belt routing diagram in a suitable location under the hood.



*The System Identification Plate must be attached to the vehicle at the time of installation. This plate provides information that allows VMAC to assist with warranty, parts and repairs.*

- Locate a conspicuous area in the engine bay (where the tag will be easily noticed) to install the System ID tag.
- Mark and drill (x2) 7/64 in holes and secure the plate with the supplied self-tapping screws (Figure 42).



Figure 42 — System Identification Plate

# Air Receiver Tank



*Pressure in the air receiver tank will not be relieved when the compressor system blows down. This is normal operation. Prior to performing any service work on the system, discharge any stored air in the air receiver tank.*



*The VMAC WHASP Tank has a built-in check valve. Use of an additional check valve is not required and may cause erratic performance.*

The VMAC compressor system automatically depressurizes when it is shut-down. The WHASP Tank has a built in 1-way check valve which prevents blow back and moisture from the receiver tank entering the WHASP Tank. Installation of an additional check valve will cause erratic performance.

While the air receiver tank can be installed at any height in relation to the WHASP Tank, the discharge hose running from the WHASP Tank must be installed as high as possible on the air receiver tank to prevent problems with condensation that may have accumulated in the receiver tank (Figure 43).

Drain the condensed water from the receiver tank daily.

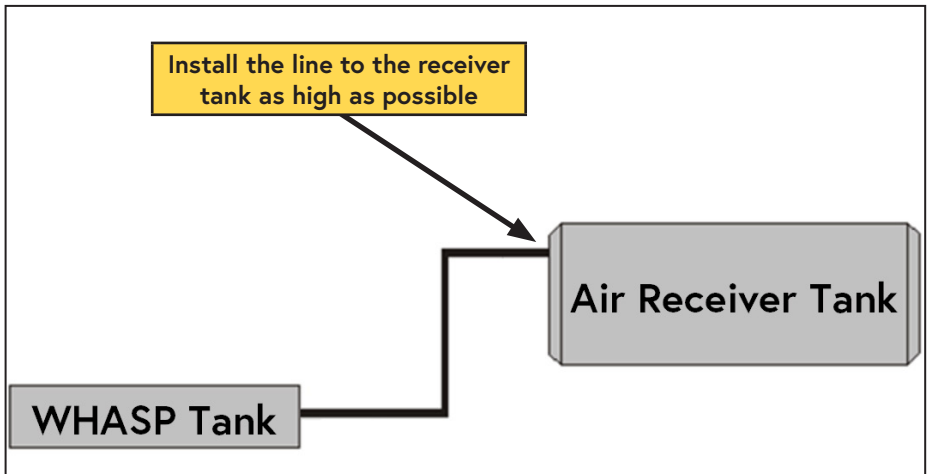

Figure 43 — Air receiver tank

## Recommended Accessories

While the compressor system will function without the following accessories, VMAC strongly recommends their use for optimal performance.

See the "Accessory Product" section of this manual on page 48 for a list of products available for purchase through VMAC.

### Larger Air Receiver Tank

A larger capacity air receiver tank provides a larger buffer as it gives the compressor time to react by increasing the engine speed and producing air before the tool stalls. It also has the advantage of lowering the duty cycle of the compressor system.

*(This application requires a minimum air receiver tank size of 6 USG).*

### Pressure Gauge

While not critical to system performance, a pressure gauge is important for fine tuning the system and simplifies any potential troubleshooting.

Install a 200 psi pressure gauge downstream of the air discharge valve.

### Pressure Regulator and/or Lubricator or FRL

The compressor can produce air pressures up to approximately 150 psi (1035 kPa). It is the responsibility of the user to know the pressure and air flow requirements of the tools powered by the air compressor system.

An appropriate air pressure regulator and lubricator can be installed downstream of the air discharge valve. Failure to regulate the air pressure may cause damage to the tool.

# Testing the Installation



*Lift the vehicle, ensuring the driven wheels are off of the ground. Support the vehicle securely with appropriately rated jack stands. Ensure there are no people around the vehicle before beginning the test.*

*If the vehicle fails the test, ensure the wiring to all of the connections are correct and secure. If additional assistance is required, contact your local VMAC dealer or call VMAC Technical Support 1-888-241-2289 or 250-740-3200.*

## Safety Test

**Ensure the following has been completed:**

- Place the transmission in "PARK" and apply the park brake. Turn the ignition key to "ON" but do not start the engine.
- Turn on the compressor and listen for the compressor clutch to engage.
- Observe the hour meter, and ensure the hourglass icon is blinking.
- Turn off the compressor switch and ensure the clutch has disengaged.

## Before Starting the Engine Checklist

**Ensure the following has been completed:**

- Check that the compressor oil level at the tank sight glass is correct.
- Complete a final inspection of the installation to ensure everything has been completed.
- Perform a final belt alignment check.
- Check all wiring for security and protection. Ensure nothing is touching the compressor body.
- Ensure all of the compressor outlets are closed.
- Ensure the parking brake is engaged and the transmission is in "PARK".
- Start the engine.

## After Starting the Engine Checklist

- Allow the vehicle to reach operating temperature.
- Turn on the compressor. The compressor clutch should engage, and the engine speed should increase in response to the throttle control. The vehicle's tachometer should indicate approximately 2,700 rpm.
- Once the engine speed reduces to base idle, turn off the compressor.
- Shut down the engine.
- Check the compressor oil level after the engine has been shut down and the oil level has had time to stabilize.



*Ensure any stored air is drained from the system prior to adding oil.*



- Add oil as necessary to bring the level to the "FULL" line in the sight glass and check for leaks.
- Install the VMAC Air Test Tool (P/N: A700052) with the 40 cfm (5/32 in) orifice installed and the ball valve closed.
- Start the engine. Assistance may be required for the next steps.



***The following tests confirm that the drive disable system is working correctly. The drive disable system prevents the VMAC throttle from increasing engine rpm unless the transmission is in "PARK" and the park brake is engaged.***

***2 people are required to perform this safety test. 1 person must remain in the driver seat and be prepared to actuate the service (foot) brake if necessary.***

***The second person will actuate the compressor switch and ball valve as necessary.***

- With the engine running and the vehicle in "PARK", release the parking brake.
- Start the compressor via the switch.\*
  - \*The compressor clutch should not engage.
  - \*Engine speed should remain at OEM base idle.
  - \*The VMAC digital throttle control should not be active at all (no LED's illuminated).
- Turn the compressor off via the switch.
- Reapply the park brake.



***The steps marked with asterisks will be repeated.***

- \*With the engine running, depress the service (foot) brake and shift the transmission out of "PARK".
- \*Turn on the compressor and open the ball valve.
  - \*The clutch should engage, but engine speed should NOT increase.
  - \*The "STATUS" and "PRNDL" LED's on the digital throttle control will turn off.
- \*Close the ball valve.
- \*Turn off the compressor.
- \*Drain any accumulated air from the system.
- \*Shift the transmission into "PARK".
- Repeat the steps marked with asterisks for all transmission selector positions, returning the gear selector to "PARK" and cycling the compressor "OFF", then "ON" after each gear is tested.



***Engine speed should not increase unless the vehicle is in "PARK".***

- Drain any air that may have accumulated during the previous tests.
- Ensure the parking brake is engaged.
- Turn on the compressor and open the ball valve.
- Release the park brake.\*
  - \*The compressor clutch should disengage.
  - \*Engine speed should drop to OEM base idle.
  - \*The VMAC digital throttle control should be deactivated (no LED's illuminated).
- Reapply the park brake.\*
  - \*The system should remain off.
  - \*Turn the compressor off.
- Close the ball valve.
- Start the compressor via the switch.\*
  - \*The system should start and build air normally. Allow the system to build to full system pressure.
- Turn off the compressor.
- Shut down the engine.
- Drain any accumulated air from the system.

## Digital Throttle Auto Calibration



*The VMAC digital throttle is equipped with an auto calibration and engine learning routine that will assist with maintaining accurate and stable engine speeds. No user input is required.*

## Final Testing

Ensure the following has been completed:

- Operate the system with an air tool (or the VMAC Air Test Tool with the appropriate orifice installed) for at least 1/2 hour (1 hour preferred).



*The WHASP Tank cooling fan is thermostatically controlled, and may start or stop without warning.*

- Road test the vehicle for approximately 20 km (14 miles).
- Observe the compressor while it is operating to ensure the belts rotate properly, pulleys rotate smoothly and nothing is rubbing or contacting hot parts.

Once the engine is turned off and the system has cooled:\*

- \*Check all components, connections and fasteners.
- \*Check the compressor oil level.

# Performance Testing and System Adjustments

System operation can be tested using the tools that will be operated by the system or by using the VMAC Test Tool (A700052) with the 40 cfm (5/32 in) orifice in the outlet to simulate tool use (Figure 44).

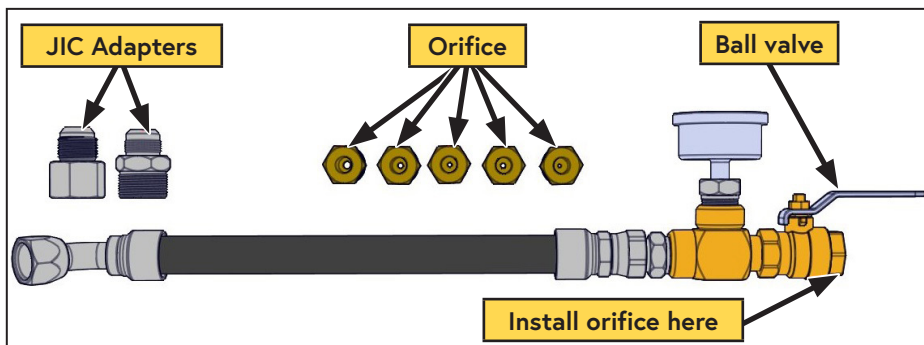

Figure 44 — A700052 VMAC Air Test Tool



**Disconnect all downstream equipment (hose reels, etc.) and connect the test tool directly to the discharge fitting on the WHASP Tank. Ensure there are no leaks in the test tool. The system may not idle down if there are leaks in the lines or fittings.**

- Install the VMAC test tool at the system outlet with the 40 cfm (5/32 in) orifice.
  - Ensure the ball valve is closed.
  - Place the transmission in "PARK" and fully apply the park brake.
  - Allow the engine to run until it is at operating temperature.
  - Turn on the air compressor system and allow it to operate until the oil is warm.
  - Observe the pressure gauge. Pressure should be approximately 150 psi.
- Open the ball valve on the test tool and observe the engine tachometer:
- Engine speed should increase to approximately 2,700 rpm.
  - Close the air valve slowly to allow the system pressure to rise. When the pressure reaches the pressure switch set-point of 150 psi, the system will disengage the compressor clutch and reduce the engine speed to base idle.
  - Once the system pressure is at maximum pressure, slowly open the ball valve on the test tool until the pressure on the gauge begins to drop. Engine speed should ramp up to approximately 2,700 rpm when the pressure drops approximately 40 psi below the pressure switch set-point.

# Digital Throttle Control Operation and Adjustments

The throttle control is configured at the factory for optimum performance at maximum cfm. In applications where maximum cfm is not required, or noise is a concern, the throttle control can be adjusted to reduce the maximum VMAC rpm.

## Safety features

The throttle control has built in safety features that will disable the system if an unsafe condition is detected, or either of the lock out parameters is not met (the vehicle must be in "PARK" and the park brake must be engaged).

If an unsafe condition is detected, the "STATUS" LED will turn off, and engine speed will return to idle. Once all unsafe conditions have been removed, the system must be cycled off, then on again to reset it. Once the system powers up, the "STATUS" LED will illuminate, and the system will operate normally.

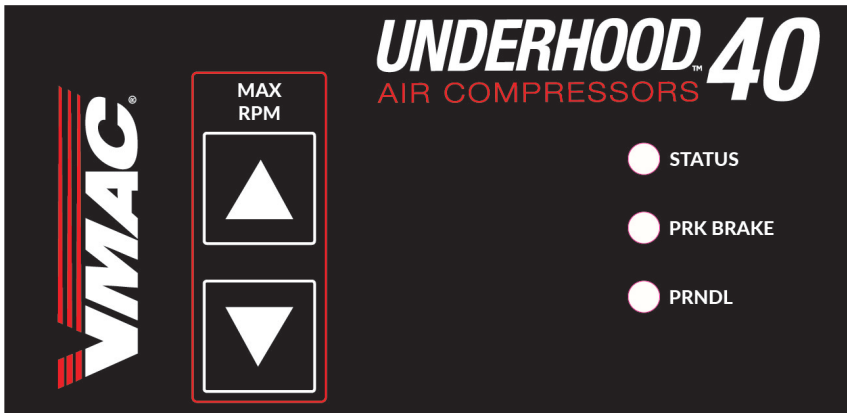





Figure 45 — Throttle control

	<p><i>If the vehicle is placed into gear, or the park brake disengaged, the "STATUS" LED and the "PRNDL" or "PRK BRAKE" LED will turn off and the throttle control will deactivate. This will reduce engine speed to base idle.</i></p> <p><i>In order to activate the system again, re-engage the appropriate lockout and cycle the VMAC "OFF" then "ON" via the control box.</i></p>
	<p><i>For more information on the digital throttle, including error codes, see the related article the VMAC Knowledge Base:</i></p> <p><a href="https://kb.vmacair.com/help/vmac-digital-throttle-control">https://kb.vmacair.com/help/vmac-digital-throttle-control</a></p> 



*In order to perform a factory reset, or adjust the "MAX RPM", the throttle needs to be active and engine rpm elevated; VMAC recommends installing the VMAC Air Test Tool (P/N: A700052) with the 40 cfm (5/32 in) orifice. Turn the system on and open the ball valve, allowing the engine speed to increase.*

## MAX RPM

The cfm produced by the system is directly related to engine speed; this system delivers 30 cfm at 2,900 rpm.

Maximum VMAC rpm can be adjusted between 2,000 rpm and 2,900 rpm (in 50 rpm increments) via the "▲" or "▼" buttons in the "MAX RPM" column.

## Factory Reset

The throttle control can be reset to factory default values via a button inside the throttle control box.

Using a paper clip (or similar object), push and hold the factory reset button for 5 seconds. All of the LED lights will illuminate for several seconds while the settings revert to their defaults. Once the LED's return to their normal state, the system is ready for use again (Figure 46).

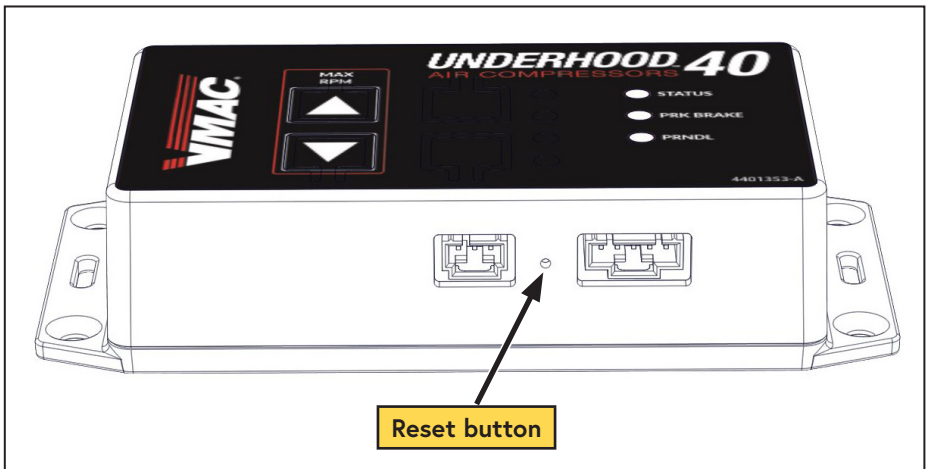

Figure 46 — Reset button

# Accessory Products from VMAC

## Compressor Service Kits



**200 Hour or 6 Month Service Kit -**

**Part number: A700263**

Includes 4 L VMAC high performance compressor oil, oil filter, air filter, and next service due decal.

**400 Hour or 1-Year Service Kit -**

**Part number: A700264**

Includes 4 L VMAC high performance compressor oil, oil filter, air filter, spin-on oil separator, safety valve, muffler, and next service due decal.

---

## Bulkhead Fittings

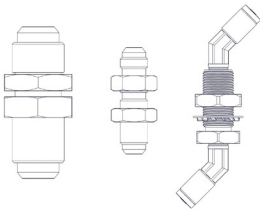

**Part number: 3801095**

**Includes:**

**Bulkhead fittings are used for passing the system discharge, oil, and scavenge hoses through the floor or body panels.**

- 3/4 in JIC bulkhead fitting P/N: 4900170.
- 3/8 in JIC bulkhead fitting P/N: 4900209.
- 1/8 in NPT bulkhead fitting P/N: 5000178.
- 2 x 45° 1/4 push-to-connect fittings P/N: 5000158.

---

## Hose Fittings

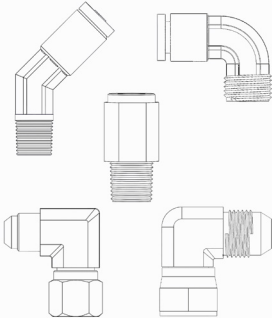

**45° 1/4 push-to-connect fitting P/N: 5000158.**

1/4 in push-to-connect fitting For PTFE scavenge tube.

**90° 1/4 push-to-connect fitting P/N: 5000020.**

1/4 in push-to-connect fitting For PTFE scavenge tube.

**Straight 1/4 in push-to-connect fitting P/N: 5000012.**

1/4 in push-to-connect fitting For PTFE scavenge tube.

**90° 3/8 in hose fitting P/N: 4900117.**

3/8 in hose fitting for Oil Return Hose.

**90° 3/4 in hose fitting P/N: 4900043.**

3/8 in hose fitting for Compressor Discharge Hose.

---

## 1/2 in x 50 ft Hose Reel

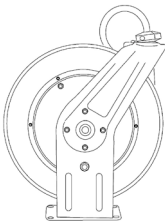

**Part number: A700007**

Spring-loaded 1/2 in x 50 ft hose reel; steel construction; full flow shaft and swivel for maximum performance.

## 6 Gallon Air Receiver Wing Tank

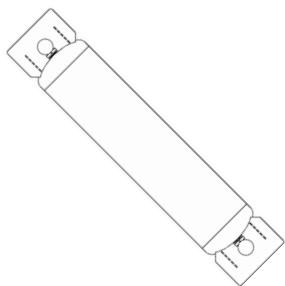

**Part number: A300056**

Air receiver tanks are used for lowering compressor duty cycle and removing water from compressed air; recommended for optimum operation of all VMAC Gas Driven, Diesel Driven, Hydraulic, and UNDERHOOD40 air compressors. Manufactured to FMVSS 121 standard; includes fittings, 170 psi pressure relief valve, and tank drain.

- Max pressure: up to 170 psi.
- Dimensions: 32 in (81.3 cm) L × 8 in (20.3 cm) D.
- Weight: 23 lb (10.4 kg).

---

## 10 Gallon Air Receiver Tank w/ Mounting Feet



**Part number: A300047**

Air receiver tanks are used for lowering compressor duty cycle and removing water from compressed air. Recommended for optimum operation of VMAC Hydraulic Air Compressors, VMAC Diesel Driven Air Compressors, UNDERHOOD40, UNDERHOOD70 – Green Series Air Compressors, and VMAC Multifunction Power Systems, which include standby mode; ASME certified; includes fittings, 200 psi pressure relief valve, tank drain, and 200 psi pressure gauge.

- Max pressure: up to 200 psi.
- Dimensions: 30 in (76.2 cm) L × 10 in (25.4 cm) D.
- Weight: 33 lb (15 kg).

---

## 35 Gallon Air Receiver Wing Tank

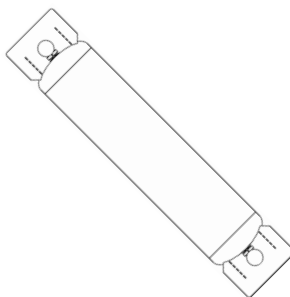

**Part number: A300010**

Air receiver tanks are used for lowering compressor duty cycle and removing water from compressed air. Recommended for optimum operation of VMAC Diesel Air Compressors, Hydraulic Air Compressors, UNDERHOOD40, UNDERHOOD70 – Green Series Air Compressors, and VMAC Multifunction Power Systems, which include standby mode; ASME certified; includes fittings, 200 psi pressure relief valve, tank drain, and 200 psi pressure gauge.

- Max pressure: up to 200 psi.
- Dimensions: 73 3/4 in (187.3 cm) L × 14 in (35.6 cm) D.
- Weight: 95 lb (43.1 kg).

## UNDERHOOD 70 Air Aftercooler

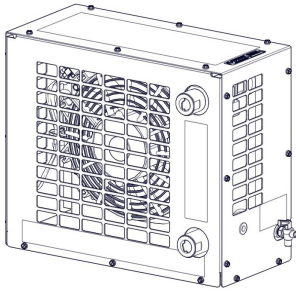

**Part number: A800070**

Improves tool performance and extends the life of air tools; removes up to 80% of water from compressed air; includes automatic water drain.

- Max air flow: 70 cfm / 175 psi.
- Port size: 3/4 in NPT inlet and outlet.
- Electrical: 12 V.
- Dimensions: 17 in (43.2 cm) L x 8.0 in (20.3 cm) W x 14.5 in (36.8 cm) H .
- Weight: 35 lb (15.8 kg).

---

## Filter Regulator Lubricator (FRL) – 70 cfm

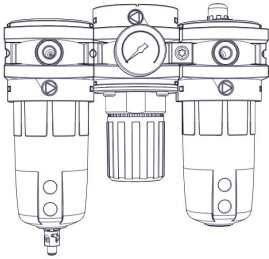

**Part number: A700151**

Extends the life of air tools; filter removes contaminants from the compressed air, adjustable regulator can reduce air pressure going to tools, lubricator adds atomized tool oil to the air stream to lubricate air tools (Tool oil not included).

- Max air flow: up to 70 cfm / 150 psi.
- Port size: 3/4 in NPT inlet and outlet.

---

## Remote Muffler

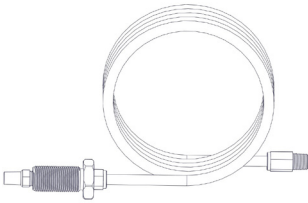

**Part number: A700224**

The A700224 WHASP remote mount muffler kit is designed to relocate the blowdown muffler to an external location. This is recommended for applications where the WHASP Tank will be located inside of a van or service body, the remote mounted muffler will reduce cabin noise when the compressor blowdown operates, and will ensure any oil vapor will be safely discharged outside of the vehicle.

---

## Interface Harness Extension

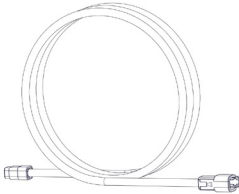

**Part number: A700265**

This interface harness extension provides an additional 10 ft of cable which allows for greater flexibility in locating the Interface Panel.





# Warranty Registration

This form must be fully completed and returned to VMAC at the time the vehicle is put into service. Warranty may be void if this form is not received by VMAC within 3 months of receiving the vehicle, or 200 hours of operation, whichever occurs first.



VMAC's Warranty policy and registration can be viewed online at:

[www.vmacair.com/warranty](http://www.vmacair.com/warranty)

## Product Information

System Identification Number: V \_\_\_\_\_

Compressor Serial Number: P \_\_\_\_\_

## Owner / End User Information

Company Name: \_\_\_\_\_

City: \_\_\_\_\_ State / Province: \_\_\_\_\_

Phone: (\_\_\_\_) \_\_\_\_-\_\_\_\_\_

Email Address: \_\_\_\_\_

Date vehicle was put into service: \_\_\_\_/\_\_\_\_/\_\_\_\_  
Day Month Year

## Installer Information

Installer Company Name: \_\_\_\_\_

City: \_\_\_\_\_ State / Province: \_\_\_\_\_

## Submitted by

Name: \_\_\_\_\_ Phone: (\_\_\_\_) \_\_\_\_-\_\_\_\_\_

Email: \_\_\_\_\_

## Vehicle Information (Optional)

Unit: \_\_\_\_\_ Year: \_\_\_\_\_

Make: \_\_\_\_\_ Model: \_\_\_\_\_

Vehicle Identification Number: \_\_\_\_\_



Manufactured by



888-241-2289



tech@vmacair.com



877-740-3202



warranty@vmacair.com



www.vmacair.com



kb.vmacair.com



1333 Kipp Road, Nanaimo, B.C., V9X 1R3 Canada