

UNDERHOOD™ **40** AIR COMPRESSORS



Installation Manual for VMAC System

V400021

**2020 – 2022 Ford Super Duty F-250 – F-600
6.7 L Diesel**

www.vmacair.com

Table of Contents

Safety	3
Warranty	4
General Information.....	6
Preparing for Installation	8
Installing the Main Bracket, Compressor and Belt.....	12
Installing the Waste Heat Air Separator Package (WHASP) Tank ...	20
Hose Requirements	22
Routing and Connecting the Hoses	23
Adding Oil to the System	27
Installing the Control System.....	28
Completing the Installation	35
Air Receiver Tank.....	37
Recommended Accessories	38
Testing the Installation.....	39
Performance Testing and System Adjustments.....	42
Accessory Products from VMAC.....	44
Warranty Registration.....	48

Revision	Revision Details	Revised by	Checked by				Implemented
			Eng.		Tech.	Qual.	
			Mech.	Elec.			
D	ECN: 23-082 Cap model year	MSP	N/A	N/A	MSP	N/A	18 Apr. 2023

Additional Application Information

- Use of an air receiver tank (minimum 6 USG) is required with this application.
- 2020 – 2022 Ford Super Duty F-250 – F-600 6.7 L Diesel.
- This system is not compatible with dual alternator vehicles.
- The vehicle must be equipped with a secondary cooling system water pump with integrated mounting ears. See page 8 of this manual to identify. For water pumps without integrated mounting ears, order VMAC adaptor kit P/N: A900022.

Registered Trademarks

All trademarks mentioned in this manual are the property of their respective owners. VMAC's use of manufacturers' trademarks in this manual is for identification of the products only and does not imply any affiliation to, or endorsement of said companies.

Loctite®, **Loctite® 242** and **Loctite® 567** are registered trademarks of Henkel AG & Company KGaA.

Nylok® is a registered trademark of Nylok Fastener Corporation.

Eaton Aeroquip® is a registered trademark of EATON AEROQUIP INC.

Ford® and **Super Duty®** are registered trademarks of Ford Motor Company.

Important Information

The information in this manual is intended for certified VMAC installers who have been trained in installation and service procedures and/or for anyone with mechanical trade certification who has the tools and equipment to properly and safely perform the installation or service. Do not attempt installation or service without the appropriate mechanical training, knowledge and experience. Follow all safety precautions. Any fabrication for correct fit in modified vehicles must follow industry standard "best practices".

Notice

Copyright © 2020 VMAC Global Technology Inc. All Rights Reserved. These materials are provided by VMAC for informational purposes only, without representation or warranty of any kind, and VMAC shall not be liable for errors or omissions with respect to the materials. The only warranties for VMAC products and services are those set forth in the express warranty statements accompanying such products and services, if any, and nothing herein shall be construed as constituting an additional warranty. Printing or copying of any page in this document in whole or in part is only permitted for personal use. All other use, copying or reproduction in both print and electronic form of any part of this document without the written consent of VMAC is prohibited. The information contained herein may be changed without prior notice.

Printed in Canada

Safety

Important Safety Notice

The information contained in this manual is based on sound engineering principles, research, extensive field experience and technical information. Information is constantly changing with the addition of new models, assemblies, service techniques and running OEM changes. If a discrepancy is found in this manual, contact VMAC Technical Support prior to initiating or proceeding with installation, service or repair. Current information may clarify the issue. Anyone with knowledge of such discrepancies, who proceeds to perform service and repair, assumes all risks.

Only proven service procedures are recommended. Anyone who departs from the specific instructions provided in this manual must first ensure that their safety and that of others is not being compromised, and that there will be no adverse effects on the operational safety or performance of the equipment.

VMAC will not be held responsible for any liability, consequential damages, injuries, loss or damage to individuals or to equipment as a result of the failure of anyone to properly adhere to the procedures set out in this manual or standard safety practices.

Safety should be the first consideration when performing any service operations. If there are any questions concerning the procedures in this manual, or more information is required, please contact VMAC Technical Support prior to beginning work.

Safety Messages

This manual contains various warnings, cautions and notices that must be observed to reduce the risk of personal injury during installation, service or repair and the possibility that improper installation, service or repair may damage the equipment or render it unsafe.



This symbol is used to call attention to instructions concerning personal safety. Watch for this symbol; it points out important safety precautions, it means, "Attention, become alert! Your personal safety is involved". Read the message that follows and be aware of the possibility of personal injury or death. As it is impossible to warn of every conceivable hazard, common sense and industry standard safety practices must be observed.



This symbol is used to call attention to instructions on a specific procedure that if not followed may damage or reduce the useful life of the compressor or other equipment.



This symbol is used to call attention to additional instructions or special emphasis on a specific procedure.

Warranty

VMAC Standard Warranty (Limited)

For complete warranty information, including both VMAC Standard Warranty (Limited) and VMAC Lifetime Warranty (Limited) requirements, please refer to our current published warranty located at: www.vmacair.com/warranty



If you do not have access to a computer, please contact us and we will be happy to send you our warranty.

VMAC's warranty is subject to change without notice.

VMAC Lifetime Warranty (Limited)

A VMAC Lifetime Limited Warranty is offered on the base air compressor only and only on UNDERHOOD, Hydraulic Driven, Transmission Mounted, Gas and Diesel Engine Driven Air Compressors, Multifunction Power Systems, and other products as defined by VMAC, provided that (i) the purchaser fully completes and submits a warranty registration form within 3 months of purchase, or 200 hours of operation, whichever occurs first; (ii) services are completed in accordance with the Owner's Manual; (iii) proof of purchase of applicable service kits are made available to VMAC upon request.



The VMAC Lifetime Warranty is applicable to new products shipped on or after 1 October, 2015.

Warranty Registration

The VMAC warranty registration form is located near the back of this manual. This warranty registration form must be completed and sent to VMAC at the time of installation for any subsequent warranty claim to be considered valid.

There are 4 ways the warranty can be registered with VMAC:



www.vmacair.com/warranty



warranty@vmacair.com



(877) 740-3202



VMAC - Vehicle Mounted Air Compressors
1333 Kipp Road, Nanaimo, BC, Canada V9X 1R3

VMAC Warranty Claim Process



VMAC warranty work must be pre-authorized by VMAC. Claims are processed via our dealer network. If you are not a VMAC dealer, please select one to work with via our Dealer Locator: <https://www.vmacair.com/dealer-locator/>



1. Communicate with VMAC Technical Support at 1-888-241-2289 or tech@vmacair.com to help diagnose/troubleshoot the problem prior to repair. VMAC technical support will require the VMAC System ID, and hours on the compressor.
2. VMAC will provide direction for repair or replacement of the failed components.
3. If requested, failed parts must be returned to VMAC for evaluation.
4. Dealers may login to the VMAC website to view the "VMAC Labour Time Guide" (under "Agreements") to see the allowable warranty labour times.
5. Warranty invoices must include the Service Ticket number, VMAC System ID#, hours on the compressor, and a detailed description of the work performed.
6. VMAC Warranty does not cover consequential damages, overtime charges, mileage, travel time, towing/recovery, cleaning or shop supplies.
7. Dealers submit warranty claims on behalf of the Vehicle Owner/End User affected by the defective part(s). The dealer ensures that all warranty credits are refunded back to the Vehicle Owner/End User who made the initial warranty claim.



In order to qualify for Lifetime Warranty (Limited), the completed warranty registration form must be received by VMAC within 3 months of the buyer receiving the Product(s), or 200 hours of operation, whichever occurs first.

If the completed warranty registration form has not been received by VMAC within 3 months of the buyer receiving the Product(s), or 200 hours of operation, the warranty period will be deemed to commence 30 days from the date of shipment from VMAC.

Failure to follow the warranty claim process may result in denial of the warranty claim.

VMAC Product Warranty Policies & Warranty Registration can be found on the VMAC website (see previous page for URL).

General Information

Optional Equipment Compatibility

While VMAC strives to design systems compatible with optional OEM equipment (such as running boards), it is impractical to develop systems that accommodate every OEM and aftermarket option or add-on. Whenever possible, VMAC endeavors to advise of compatibility issues in the "Additional Application Information" section of the manual. Even when specific optional equipment is determined by VMAC to be incompatible, it does not preclude the vehicle upfitter or end user from modifying the optional equipment to make it compatible with the installed VMAC system. VMAC does not warranty or accept responsibility or liability for the fitment, function or safety of any products modified in any way not expressly outlined in the installation manual.

Before Starting



Note and label all parts that are removed from the vehicle as many of the OEM parts will be reused during the installation of the VMAC system.

Read this manual prior to beginning the installation to ensure familiarity with the components and how they will fit on the vehicle. Identify any variations from the application list such as vehicle model, engines, or optional equipment (e.g., dual alternator, active steering assist, etc.).

Open the package, unpack the components and identify them using the Illustrated Parts List (IPL) included in the Fastener Pack.

Hose Information

Depending on other installed equipment, it might be necessary to move the air/oil separation tank from its intended location. The hoses used in VMAC compressor systems have a specific inner liner that is compatible with VMAC compressor oil. Use of hoses other than those supplied or recommended by VMAC may cause compressor damage and may void your warranty. Please contact VMAC for replacement hoses and further information.

Ordering Parts

To order parts, contact a VMAC dealer. The dealer will ask for the VMAC serial number, part number, description and quantity. Locate the nearest dealer online at www.vmacair.com/dealer-locator or call 1-877-912-6605.



Special Tools Required

- Pneumatic fan wrench removal set (such as Lisle® 43300) or a manual fan pulley holder (such as KD Tool® KD3900).

Torque Specifications

All fasteners must be torqued to specifications. Use manufacturers' torque values for OEM fasteners.

The torque values supplied in Table 1 are intended for VMAC supplied components, or for use as a guide in the absence of a torque value provided by an OEM.



Apply Loctite 242 (blue) to all fasteners (except nylon lock nuts) unless otherwise stated.

Torque values are with Loctite applied unless otherwise specified.

Standard Grade 8 National Coarse Thread								
Size (in)	1/4	5/16	3/8	7/16	1/2	9/16	5/8	3/4
Foot pounds (ft•lb)	9	18	35	55	80	110	170	280
Newton meter (N•m)	12	24	47	74	108	149	230	379

Standard Grade 8 National Fine Thread					
Size (in)	3/8	7/16	1/2	5/8	3/4
Foot pounds (ft•lb)	40	60	90	180	320
Newton meter (N•m)	54	81	122	244	434

Metric Class 10.9						
Size (mm)	M6	M8	M10	M12	M14	M16
Foot pounds (ft•lb)	4.5	19	41	69	104	174
Newton meter (N•m)	6	25	55	93	141	236

Table 1 — Torque Table

Preparing for Installation



Preparation for installation is very important. Missing a step or an item can cause problems in the installation or damage to components.

- Check off each item as it is completed so that no steps are missed.



When disassembling engine components, cover the openings to prevent debris from entering the system.



Apply Loctite 242 (blue) to all fasteners (except nylon lock nuts) unless otherwise stated.



Due to the variety of possible WHASP tank installation locations, VMAC does not include bulkhead fittings or hoses to run between any bulkhead and the WHASP tank. VMAC recommends determining where the WHASP tank will be located early in the installation so that appropriate hose lengths and bulkhead fittings can be ordered. Refer to page 20 for WHASP tank installation requirements.

- Confirm the vehicle is equipped with the compatible secondary cooling system water pump. If the secondary cooling system water pump does not have integrated mounting ears VMAC adaptor P/N: A900022 must be ordered (Figure 1).

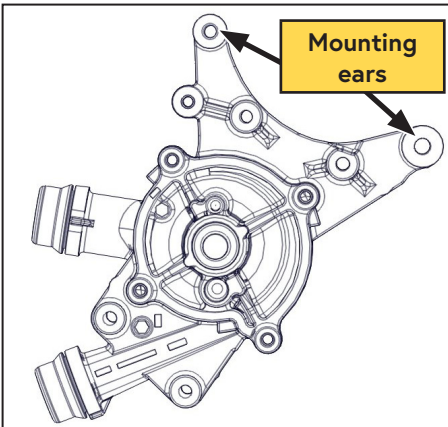

Water pump with integrated mounting ears

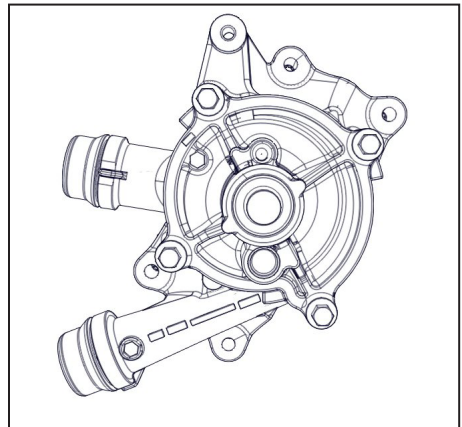

Water pump without integrated mounting ears

Figure 1 — Identifying compatible secondary cooling system water pump

- Disconnect the battery leads and cover the battery terminals to prevent electrical shorts.
- Remove the air filter box cover, air filter, and intake tube (from the air filter outlet to the turbo inlet on the engine).

- Cover the turbo inlet and the outlet on the air-box cover to prevent debris entering the engine.

Optional: The fan shroud can provide extra room while installing the main bracket and compressor*:

- *Drain the secondary radiator into a clean container. Set the coolant aside for use later.
- *Disconnect the hoses from the secondary coolant reservoir (attached to passenger side of fan shroud), and remove the reservoir from the fan shroud.
- Keeping the power steering lines connected, remove the bolt securing the power steering reservoir to the upper fan shroud. Slide the reservoir up out of the clip securing it to the upper fan shroud and secure it out of the way with cable ties.



The power steering reservoir cap will leak if the reservoir is not kept upright.

- Remove the (x5) bolts (x3 on the driver side and x2 on the passenger side) and the wire clips securing the upper fan shroud and remove it from vehicle.
- Unhook the coolant hose from the upper fan shroud.
- Slide a sheet of cardboard between the fan and the radiator to protect the radiator from accidental damage.
- Disconnect the fan clutch wire and remove the bolt securing the fan stator arm to the engine. Retain the bolt as it will be reused later.



For ease of fan removal and installation, it is recommended that a pneumatic fan wrench removal set (such as Lisle 43300) or a manual fan pulley holder (such as KD3900) is used.

- Remove the fan and pull it out of the engine bay.
- Remove the 4 fan stator nuts. Remove the fan stator by rotating it to clear the lower lip of the lower fan shroud. It is not necessary to remove the lower fan shroud.
- Remove the OEM Front End Accessory Drive (FEAD) belt.



This VMAC compressor uses the OEM FEAD belt, and is installed in the optional secondary OEM alternator location. As such, this compressor system is not compatible with vehicles equipped with dual OEM alternators.

Confirm the driver side idler is on the appropriate post (Figure 2, Figure 3).

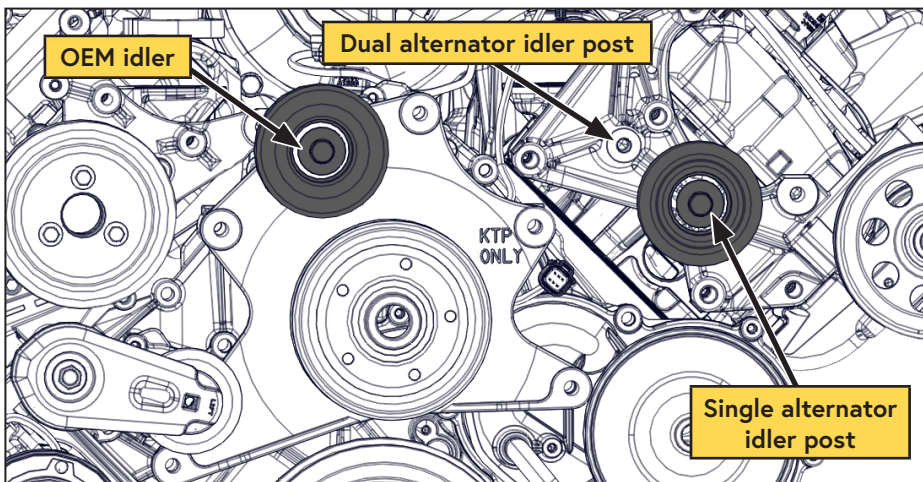

Figure 2 — OEM idlers

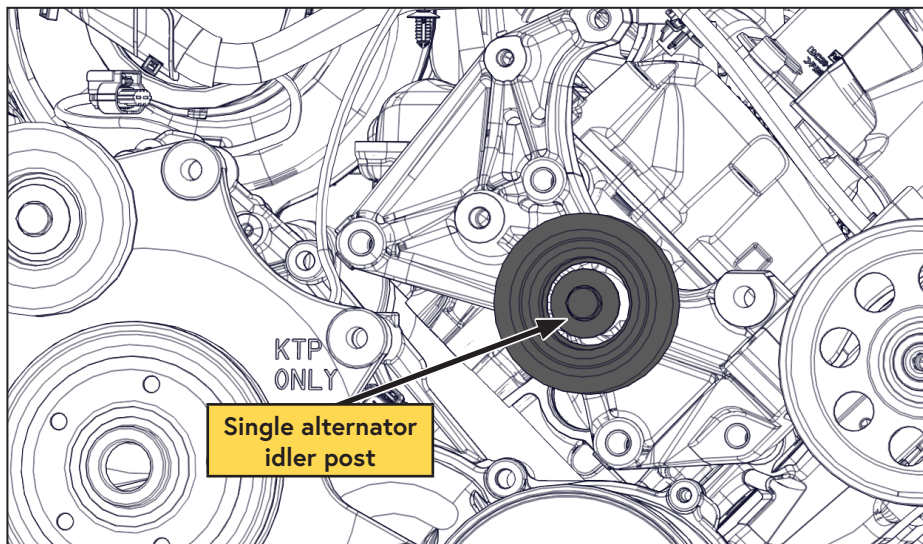

Figure 3 — Confirm idler location



If the vehicle came equipped with smooth idlers, they must be removed and replaced during the compressor installation with the ribbed idlers included in this kit.



If installing the VMAC adaptor P/N: A900022 with the steel bracket, install the idler on the dual alternator idler post (Figure 2, Figure 4).

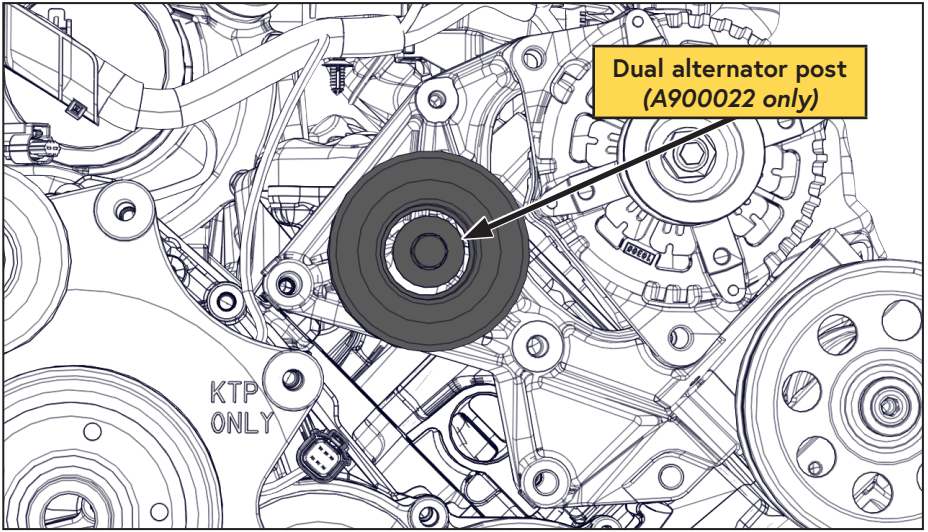

Figure 4 — A900022 idler location

Installing the Main Bracket, Compressor and Belt



Apply Loctite 242 (blue) to all fasteners (except nylon lock nuts) unless otherwise stated.



For vehicles equipped with water pumps that do not have integrated mounting ears, please refer to the instructions in the A900022 VMAC adaptor manual.

- Cut the cable ties securing the OEM wiring bundle to the wiring tray. Use a 10 mm socket to remove the wiring tray (Figure 5).

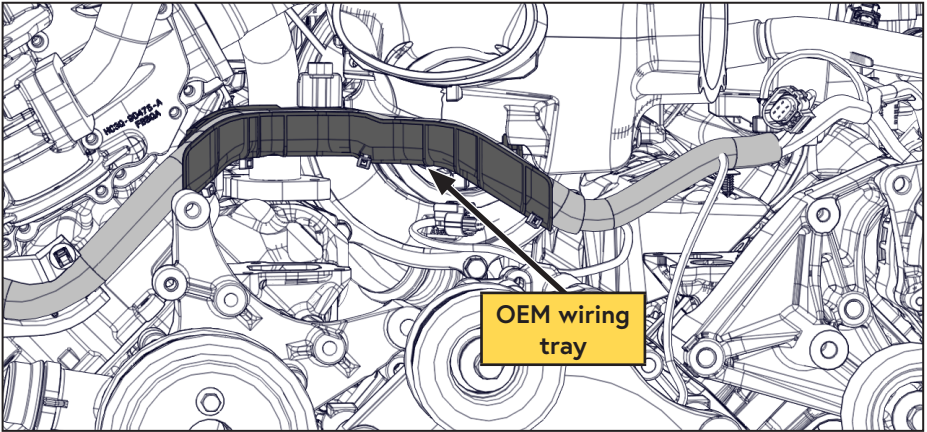

Figure 5 — OEM wiring tray

- Using cable ties, secure the harness to the cable tray mounting bosses (Figure 6).



Figure 6 — Preparing for main bracket installation

- Loosen the (x2) front passenger side fasteners on the intake manifold (Figure 7).

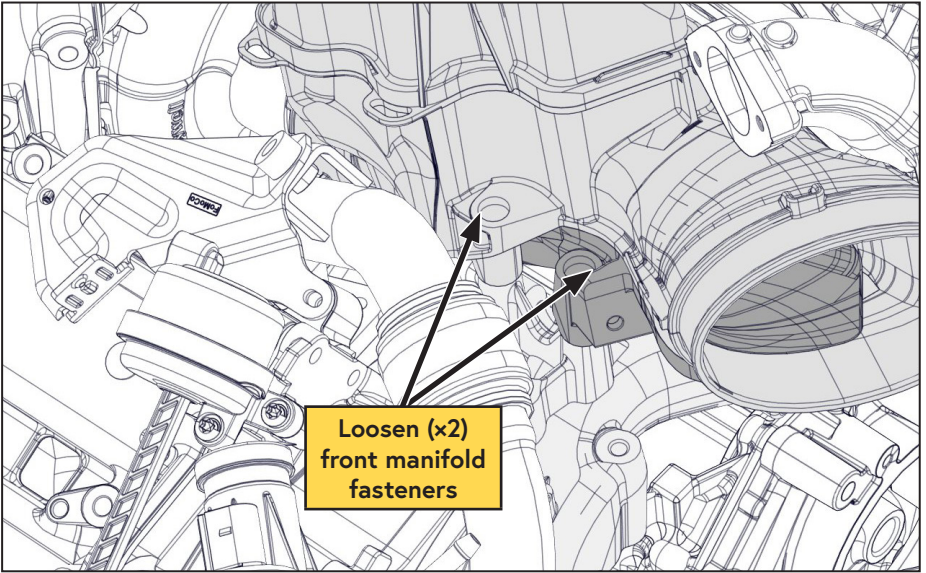

Figure 7 — Preparing for main bracket installation

- Remove the idler beside the power steering pump and set aside for later (Figure 8).

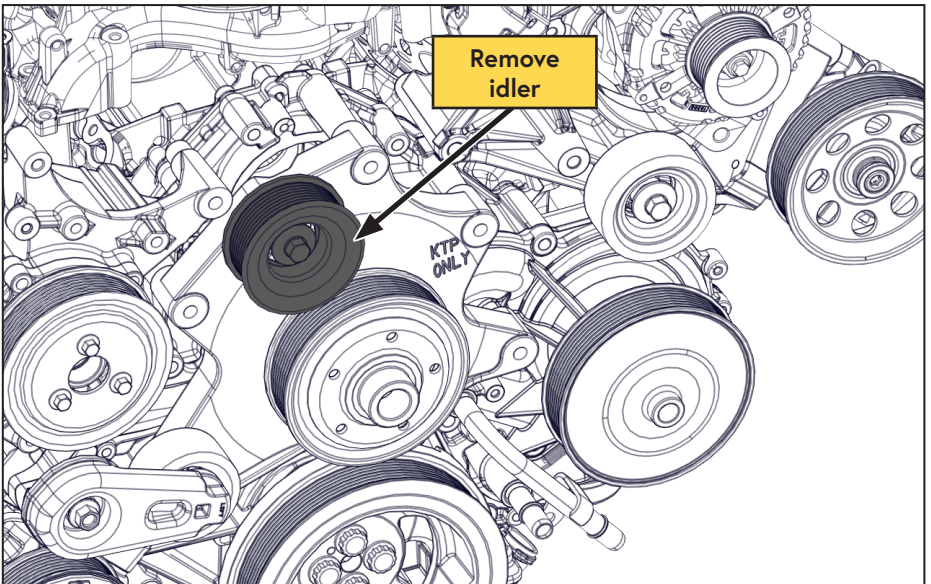

Figure 8 — Preparing for main bracket installation

- Install the smaller rear bracket onto the main bracket using the (x2) M8 × 1.25 × 30 mm fasteners (Figure 9).

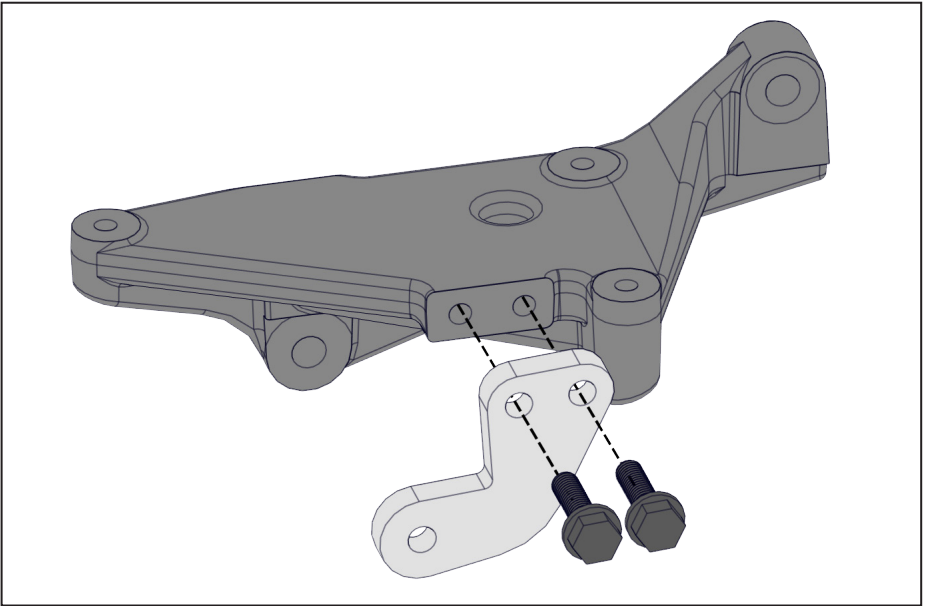

Figure 9 — Installing the rear bracket

- Install the compressor and main bracket assembly onto the engine (Figure 10).

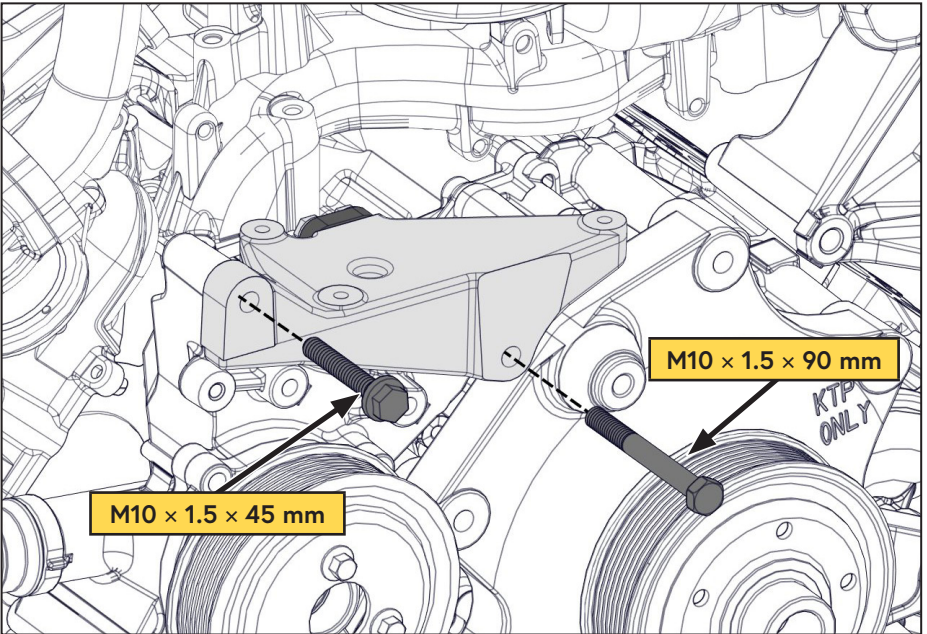

Figure 10 — Mounting the compressor onto the engine

- The compressor discharge fitting will be oriented towards the oil return fitting, use a 3/4 in wrench to hold the fitting and a 7/8 in wrench to ensure the locking nut is tight (Figure 11).

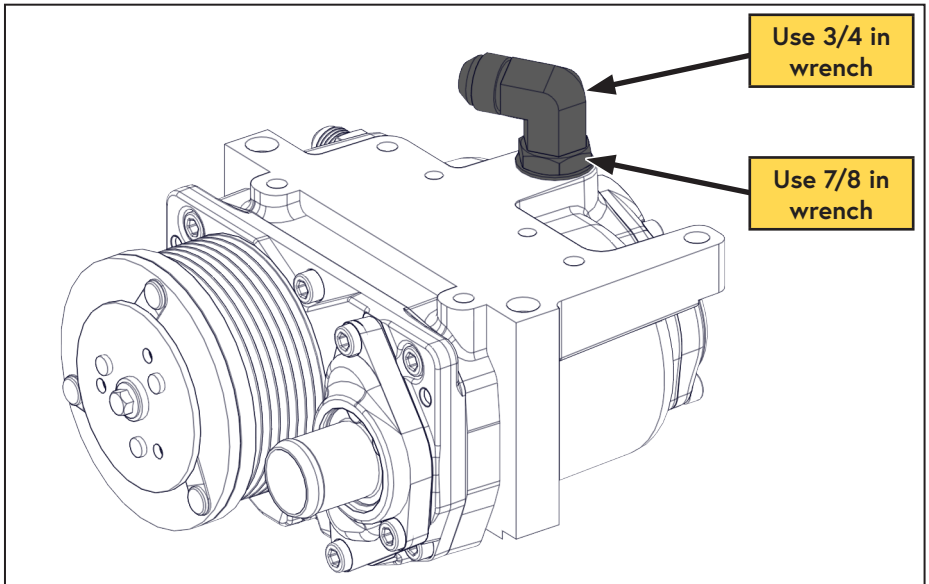

Figure 11 — Compressor discharge fitting

- Apply plastic loom or equivalent hose protection (not supplied) to the 1/2 in x 24 1/2 in and 3/4 in x 215 in discharge hoses, as well as the 3/8 in x 240 in oil return hose.
- Install the 45° fitting from the 1/2 in x 24 1/2 in discharge hose onto the compressor discharge fitting. Orient the hose in the same direction as the #6 JIC oil fitting on the side of the compressor and tighten the hose securely (Figure 12).

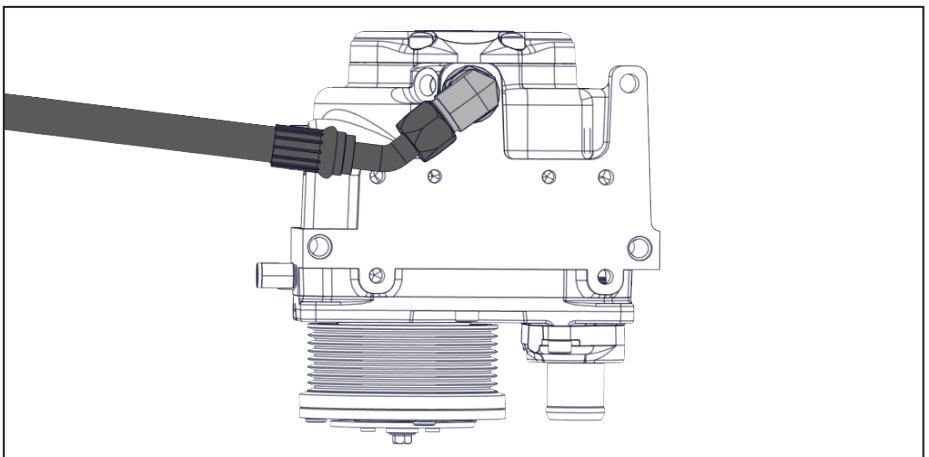

Figure 12 — Compressor discharge fitting

- Insert one of the M8 × 1.25 × 100 mm fasteners into the front driver side mount of the compressor.



Ensure the discharge fitting does not contact the main bracket and that the hose does not twist or kink while the compressor is installed

- Install the compressor onto the VMAC main bracket (Figure 13).

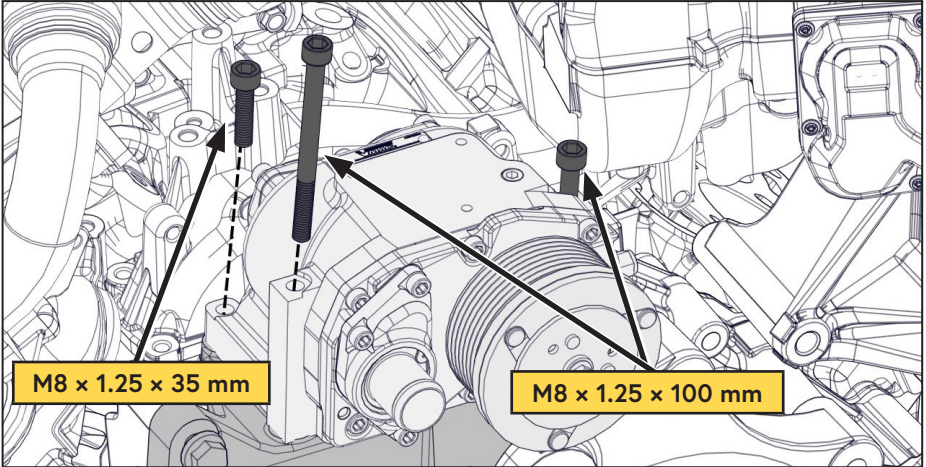

Figure 13 — Mount compressor



If the vehicle was equipped with smooth idlers in the locations shown, replace them with the VMAC supplied ribbed idlers (Figure 14).

- Reinstall the idler removed earlier (Figure 14).

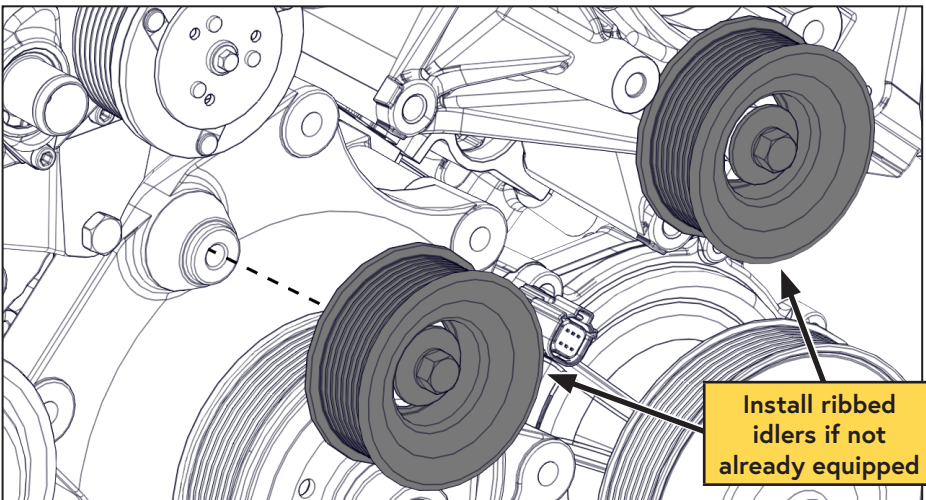

Figure 14 — Reinstall the idler

- Install the air filter bracket onto the air filter assembly (Figure 15).

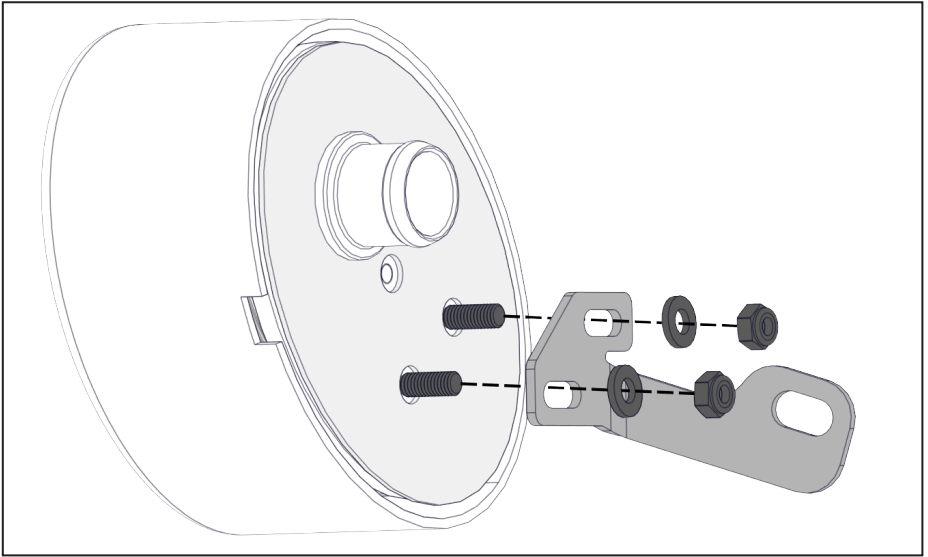
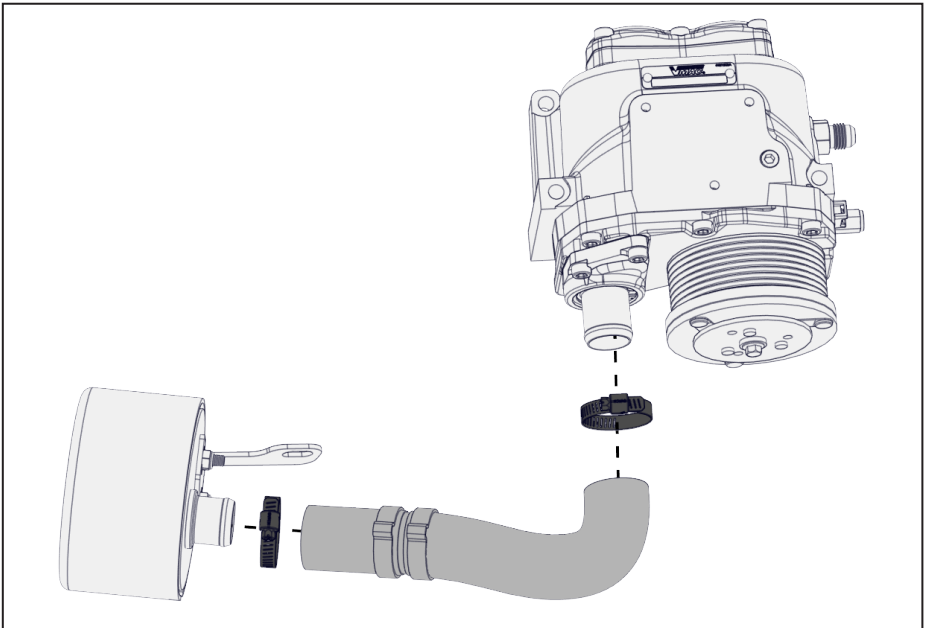
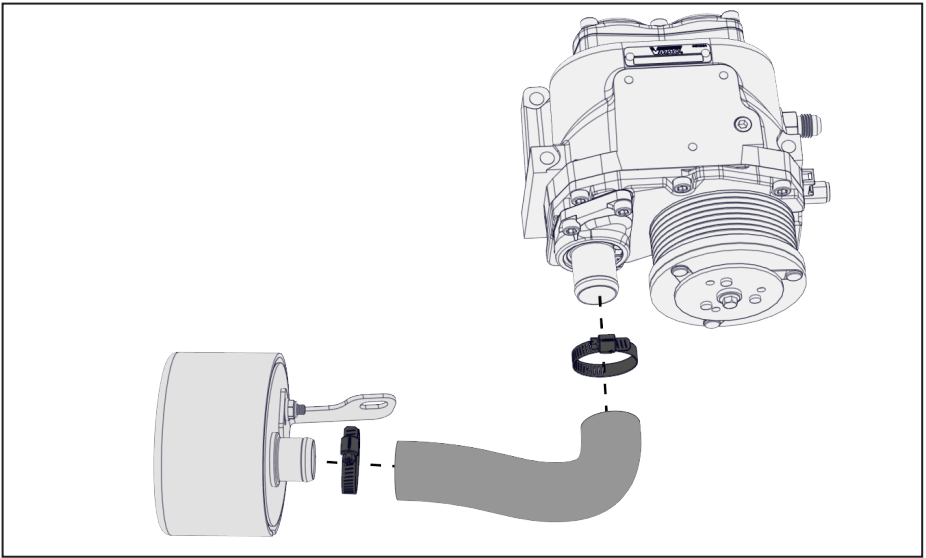

Figure 15 — Install the air filter bracket

- Install the supplied intake tube (if using A900022 kit, install the intake hose supplied with that adaptor kit) onto the air filter assembly and the compressor inlet, and secure with the supplied hose clamps (Figure 16, Figure 17).



**Figure 16 — Installing the compressor air filter
(standard main bracket)**



**Figure 17 — Installing the compressor air filter
(A900022 main bracket)**

- Secure the VMAC air filter bracket in place using the fan shroud mounting stud (Figure 18).

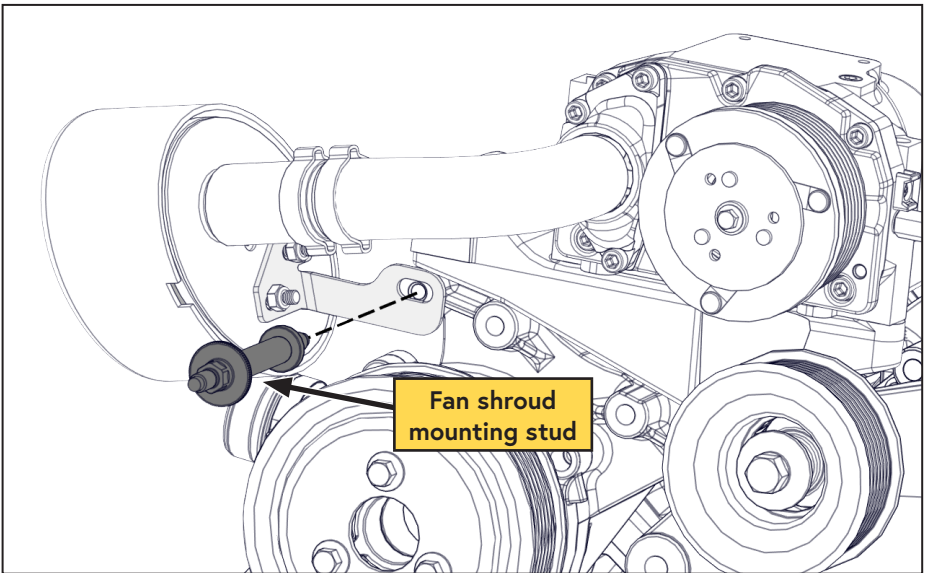

Figure 18 — Securing the filter assembly

i *If necessary, trim the compressor side of the hose to provide adequate clearance to the fan. If modifying the hose, trim as little as possible to prevent causing a restriction between the hose and the snout of the intake.*

- Retorque the (x2) intake manifold fasteners.
- Install and tension the VMAC supplied FEAD belt (Figure 19, Figure 20).

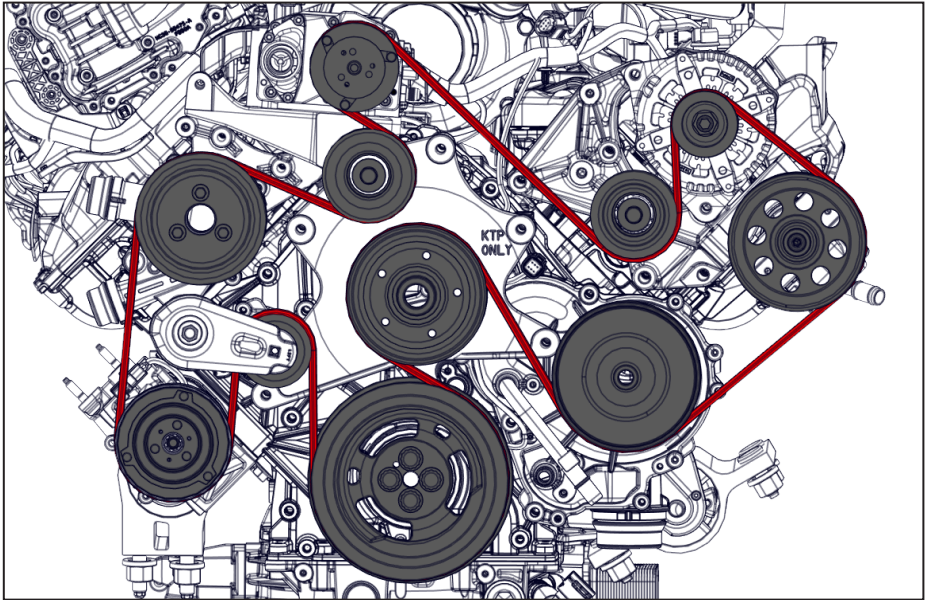

Figure 19 — Belt routing

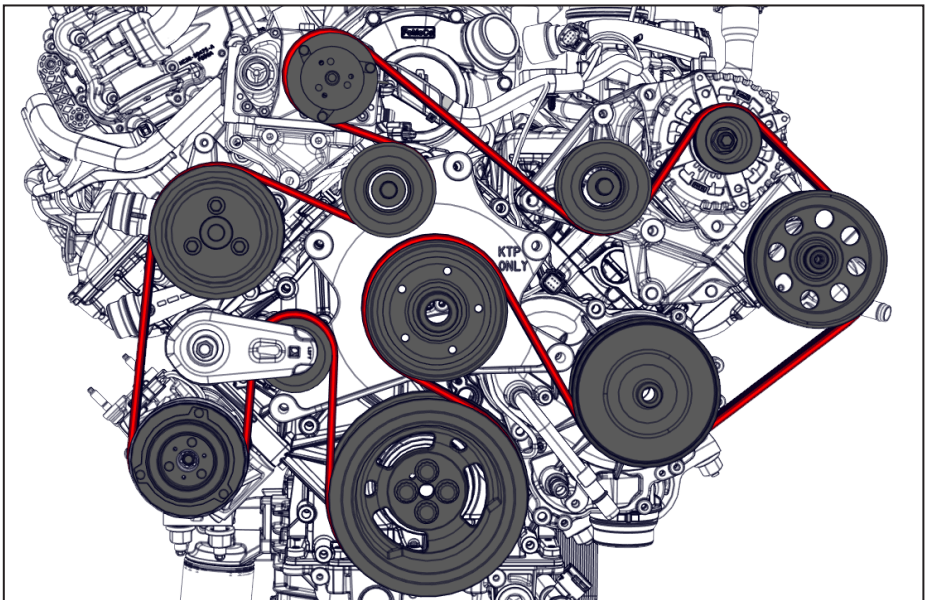

Figure 20 — A900022 Belt routing

Installing the Waste Heat Air Separator Package (WHASP) Tank

WHASP Tank location guidelines



When determining a mounting location for the WHASP Tank, ensure the following conditions are met:

- Adequate supply of fresh air and venting for the cooling fan.
- Minimum of 12 in of clearance at the front of the cooling fan.
- Minimum of 6 in clearance at the rear of the unit.
- Hose connections and wiring are accessible.
- Mounted on a level surface.
- Impact protection.
- The oil level sight glass is easily accessible.
- The oil fill and drain ports are accessible for servicing.
- Minimize the hose lengths to maximize performance.

Mounting the WHASP Tank

Refer to (Figure 21) for mounting dimensions.

Special consideration must be made to ensure the WHASP Tank will be protected from damage and to ensure that it has adequate ventilation.

In some cases, it may be necessary to fabricate a mounting bracket to position the tank in an appropriate location.

Secure the WHASP Tank by bolting the mounting feet to the installation surface, use M8 or 5/16 in fasteners (not supplied).

Mounting in an Enclosure or Body

Mounting the WHASP Tank in an enclosure will limit access to cooling air or restrict the escape of hot air from around the unit and will have an adverse effect on cooling.

Ensure adequate ventilation is provided for the cooling system to function properly.

It is not possible to make absolute recommendations regarding ventilation because of the widely differing configurations that are possible. Duty cycle, ambient temperature and enclosure shape are some of the important variables that need to be taken into account when determining the suitability of enclosure mounting.

Cool air ducted to the cooler and installing an exhaust fan to remove hot air is recommended.



Confirm the hose lengths included in this kit when determining the location of the WHASP Tank and bulkhead fittings. Hose lengths can be found in the Illustrated Parts List (IPL). If the WHASP Tank or bulkhead fitting location requires longer hoses, contact a local VMAC dealer. See page 7 for ordering information .

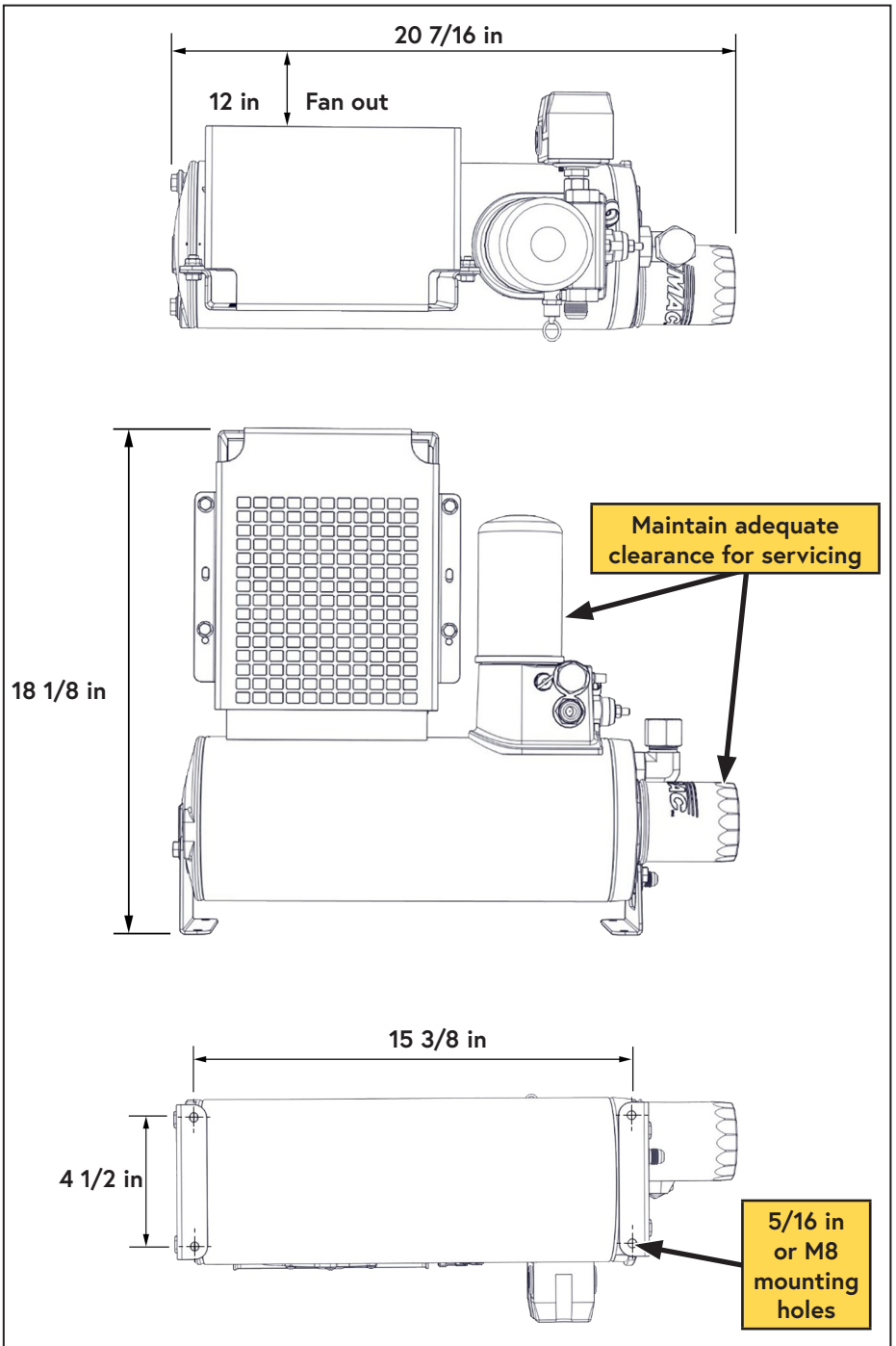

Figure 21 — Minimum WHASP Tank mounting clearances

Hose Requirements



*Only attempt to shorten the supplied hose if there is access to the appropriate equipment. **Do not** attempt to cut the hose and splice it using hose clamps.*



VMAC Compressor oil will degrade rubber lined hoses, use only hoses with an AQP elastomer type liner. Contact VMAC Technical Support at 1-888-241-2289 for further information.

The 1/4 in PTFE tube, and the 3/8 in and 3/4 in hoses with AQP elastomer liner, are specifically designed to work with VMAC compressor oil and at compressor operating temperatures.

Based on the desired location of the WHASP Tank, the hose lengths provided with this system may not be ideal. They can be shortened or replaced as necessary, or hose extenders can be used.

VMAC recommends shortening these hoses as a preferred alternative to coiling up and securing the excess.



Shorter hose lengths will maximize system performance.



Avoid using 90° fittings wherever possible as they cause flow restrictions and negatively impact performance.

The following hoses are included with this compressor kit:

- 3/4 in × 215 in
- 3/8 in × 240 in
- 1/2 in × 24.5 in
- 1/4 in (PTFE Tube) × 216 in

If longer hoses are required:

To order parts, contact a VMAC dealer. The dealer will ask for the VMAC serial number, part number, description and quantity. To locate the nearest dealer, call 1-877-912-6605 or online at www.vmacair.com.

- Eaton Aeroquip hoses with an "AQP" type inner liner are required.
- OTC fittings are required for the VMAC supplied hose.
- Push-lock fittings are suitable if FC332 hose is used.
- If Push-lock fittings are being used, do not use hose clamps as they will damage the hose and cause leaks.

Routing and Connecting the Hoses



When routing hoses, ensure cap plugs are installed so that contaminants do not get in the line. Take care when routing hoses, as a hose failure may damage the compressor and/or cause injury.



All hoses, tubes and wires that are installed, rerouted or shifted during the installation must be secured so that they do not contact any hot, sharp or moving parts. Use rubber coated P-clips wherever possible. Follow the routing suggestions in this manual and cover all hoses with plastic loom.



Ensure there is sufficient slack in the hose routing to allow for normal engine movement.

PTFE Tubing, Loom, and Push-To-Connect Fittings

- PTFE tubing should only be cut using proper tubing cutters. Side cutters, utility knives, etc. will deform the tube, preventing a proper seal (or leave sharp edges which cut the internal O-ring).
- When applying loom to the PTFE tube, leave approximately 1 in between the loom and the fitting.
- Ensure the tube is clean, cut at 90° and that there are not sharp edges.
- Lubricate the tube and firmly push it into the fitting so that the tube fully seats in the fitting.
- Slide the collet out, away from the body of the fitting to lock the tubing in place.
- Ensure the tube does not have any "play" to prevent the O-ring from wearing.

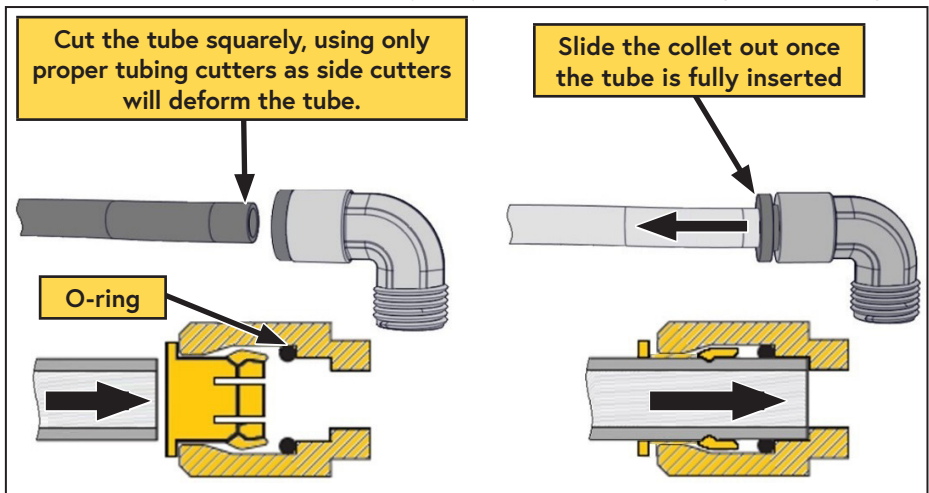

Figure 22 — Push-to-connect fittings

- Apply protective loom (not supplied) to the 1/4 in PTFE scavenge tube.
- Install the 1/4 in PTFE scavenge tube onto the compressor.
- Install the straight fitting from the 3/8 in x 240 in oil return hose onto the #6 JIC fitting on the compressor.
- Route the 1/2 in x 25 in discharge hose, the 3/8 in x 240 in oil return hose, and the 1/4 in x 240 in PTFE tube under the OEM intake manifold (Figure 23).

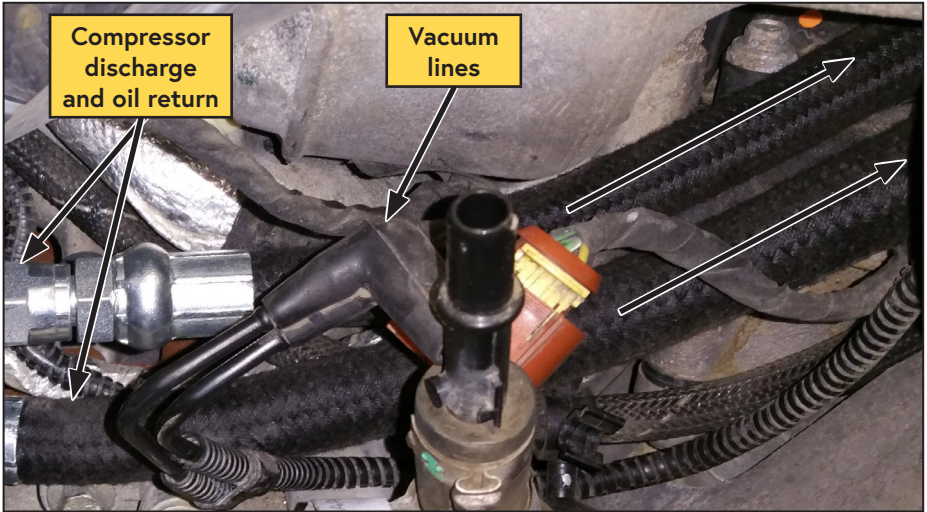

Figure 23 — Routing the hoses from the compressor

- Ensure the OEM vacuum lines and wiring are not pinched. The vacuum lines and/or wiring may need to be disconnected to route them correctly (Figure 23).
- Route the hoses and PTFE under the OEM Charge Air Cooler (CAC) tubing. Avoid the OEM vacuum lines, electrical harnesses, upper radiator hose, and the oil fill cap. The hoses should reappear near the coolant reservoir on the driver side of the engine bay (Figure 24).

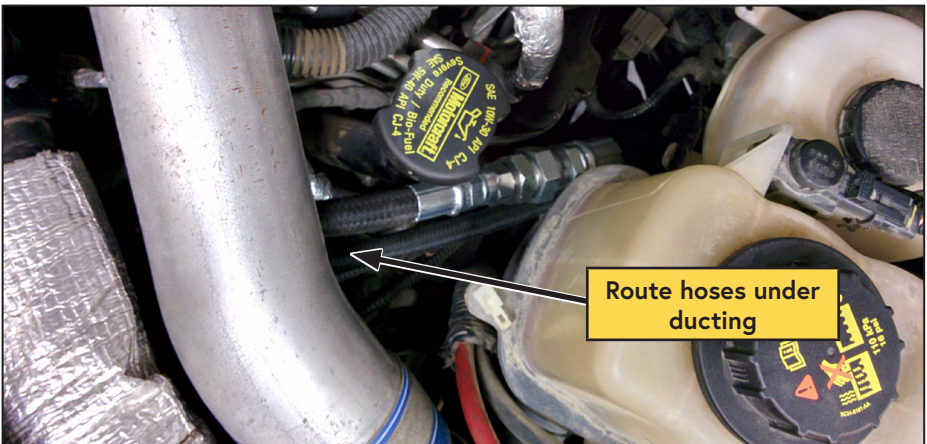

Figure 24 — VMAC hose routing

- Connect the straight fitting of the 1/2 in x 25 in hose to the supplied #8 to #12 male JIC adaptor fitting. Connect the straight fitting of the 3/4 in x 215 in hose to the other side of the #8 to #12 JIC adaptor.
- The discharge hose assembly should rest naturally near the coolant reservoir on the driver side of the vehicle (Figure 25).

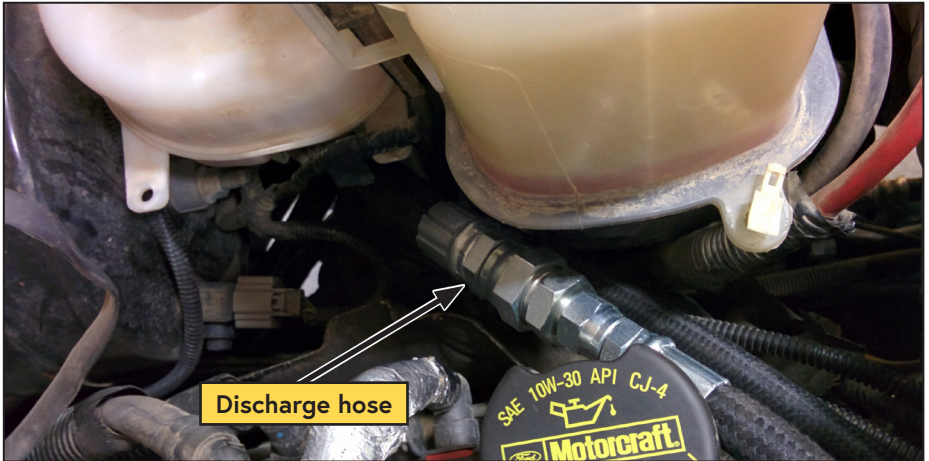

Figure 25 — Discharge hose assembly routing

- Route the discharge hose assembly, the oil return hose and the 1/4 in PTFE scavenge tube down the inner fender to the outside of the frame rail, between the body and the body mount, toward the rear of the vehicle. Ensure the hose bundle is clear of the steering shaft (Figure 26).



Figure 26 — Hose routing

- Determine a suitable routing path for the hoses running from the compressor to the WHASP tank; avoid hot, sharp or moving components.



Ensure there is sufficient slack in the hose routing to allow for normal engine movement.

- Bundle the 1/4 in PTFE tube, the 3/4 in, and the 3/8 in hoses and route them to the WHASP Tank.
- Connect the 90° fitting on the 3/4 in hose to the #12 JIC fitting (air/oil inlet) on the cooler above the fan (Figure 27).
- Connect the 90° fitting on the 3/8 in hose to the #6 JIC fitting (oil return fitting) beneath the oil filter on the tank (Figure 27).
- Connect the 1/4 in PTFE tube to the 1/4 in push-to-connect (oil scavenge) fitting near the coalescing filter (Figure 27).
- Connect the discharge fitting (#8 male JIC) to the customer's air system (hose not supplied).
- Secure all hoses, tubes, and wires with P-clips and/or cable ties.

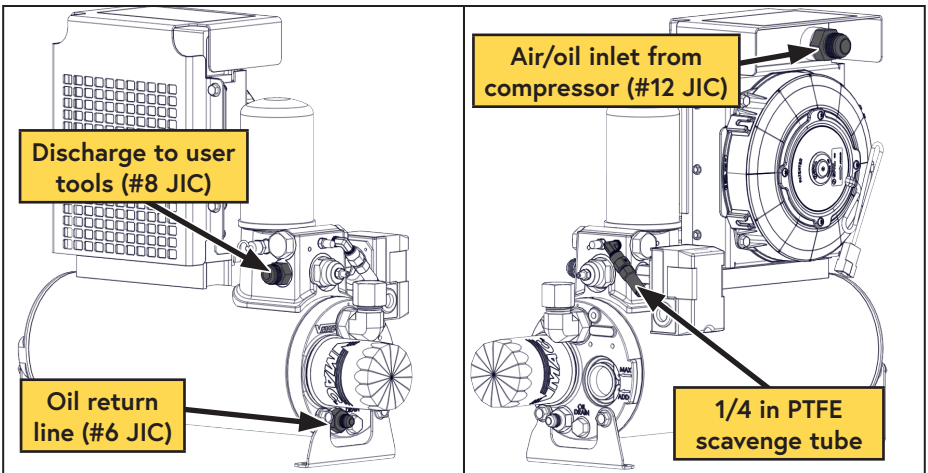

Figure 27 — WHASP Tank connections



Use of an air receiver tank (minimum 6 USG) is required with this application.

Follow the instructions on page 37 of this manual to prevent damage to the system.

Adding Oil to the System



The VMAC supplied and approved compressor oil must be used in this system. Failure to use this special oil will result in damage to the compressor and will void warranty.

Do not overfill the system. Overfilling the system with oil can flood the sight glass window and make the system appear empty.

- Remove the fill cap on the WHASP Tank (above the sight glass) (Figure 28).
- Using a funnel, pour oil into the tank until the oil level in the sight glass reaches the "MAX" line. **The system capacity is 4 L** (Figure 28).
- Reinstall the fill cap and tighten it securely. Ensure the fill port remains accessible as it will be necessary to check and top up the oil after the first compressor start.

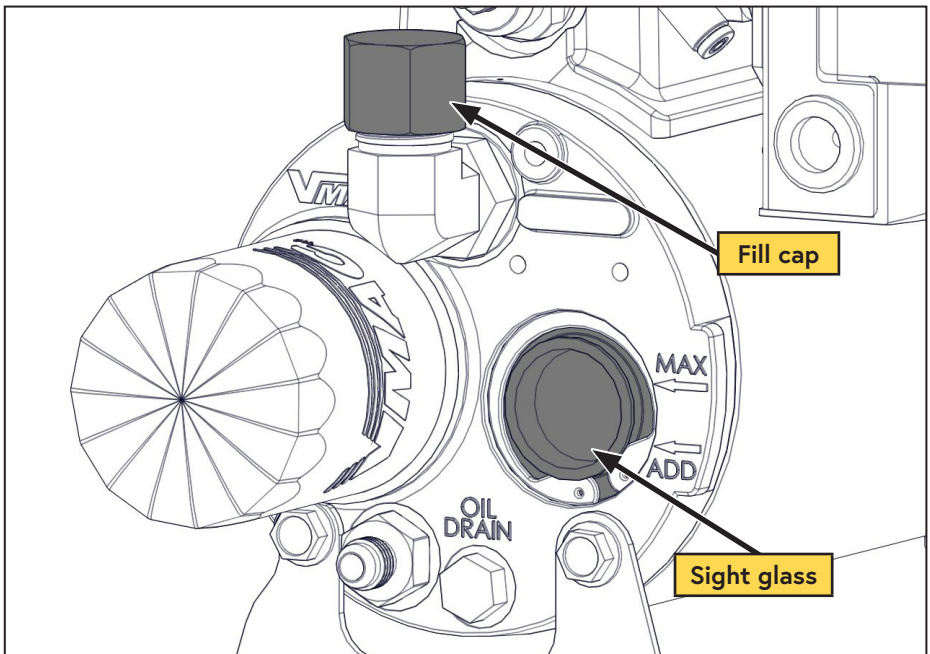

Figure 28 — Filling the WHASP Tank

Installing the Control System

Best Practices

- To confirm a good ground, use an ohm meter to measure the resistance between the ground point and the negative battery terminal. Resistance should be less than 1 Ω .
- Route all wires to ensure they will not contact hot, sharp or moving parts (including the park brake mechanism, steering column, and pedals).
- Before drilling any holes ensure there are no OEM wires, hoses, or components that may be damaged.
- Do not use a test light to probe for power on vehicle circuits, the increased current draw of the test light may damage components.
- VMAC recommends using only sealed crimp and solder butt connectors for all electrical connections.
- To ensure a durable connection, use only good quality crimping tools.
- Apply loom to all wiring:
 - Use high temperature loom in areas where high temperatures may be expected.
 - Use spiral loom in areas with high vibration.

In-line Butt Splice Connections

- Cut the wire approximately 2 in from the connector.
- Strip approximately 3/8 in from the end of both sides of the cut wire, as well as from the end of the wire being spliced in-line.
- Twist the wire to be spliced in-line, together with the "live" side of the wire (not the wire attached to the connector).
- Slide the butt connector onto the twisted wires and crimp it.
- Insert the "connector side" of the wire into butt connector and crimp it.
- Lightly tug the wires to ensure they are properly crimped.
- Using a heat gun, carefully apply heat to the butt connectors to seal the connection.

Electrical Modules

- The throttle control, control module, and interface panel are not weather proof; ensure they are mounted where they will be protected from rain, snow, mud, direct sunlight, etc. (e.g. inside the cab, service body or cabinet).
- Keep the rear of the interface panel protected.
- Ensure the control module and throttle control are mounted away from the pedals, park brake mechanism, or where they could be inadvertently knocked by occupants.

Control Components Overview

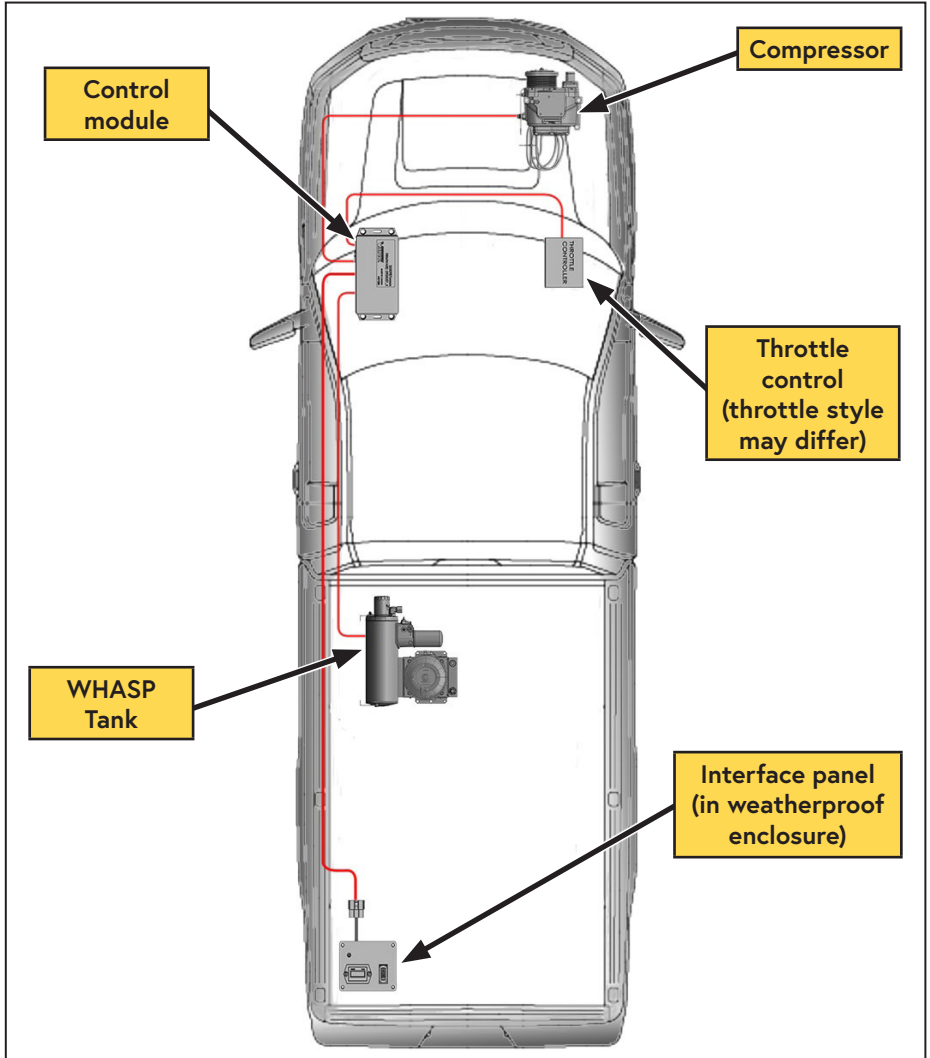

Figure 29 — General component overview
(Actual installation locations may vary)

Control Module (Figure 30)

The control module serves as the primary input/output interface between the vehicle and the various VMAC components (compressor, throttle control, WHASP Tank, Control Interface, etc.).

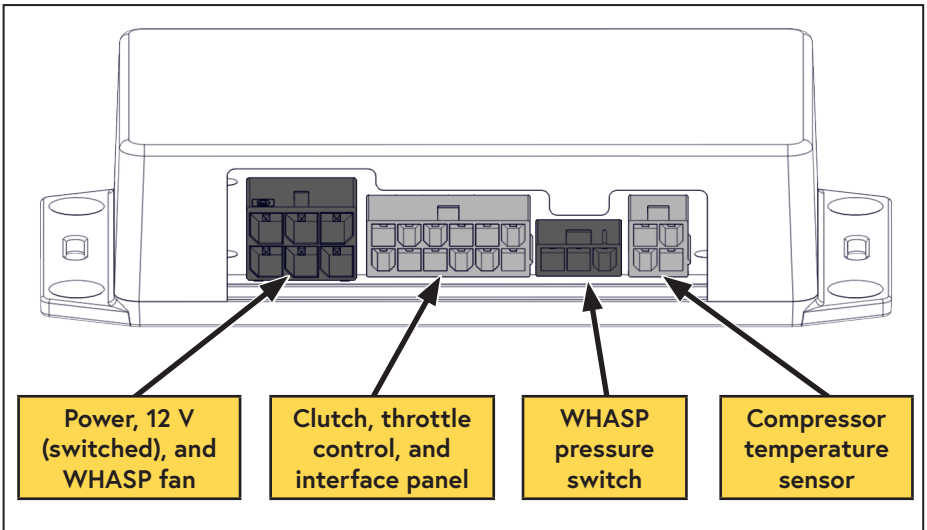

Figure 30 — Control module

Interface Panel (Figure 31)

The interface panel serves as the operator's control panel and contains the "ON/OFF" switch, compressor status light, and the compressor hour meter.

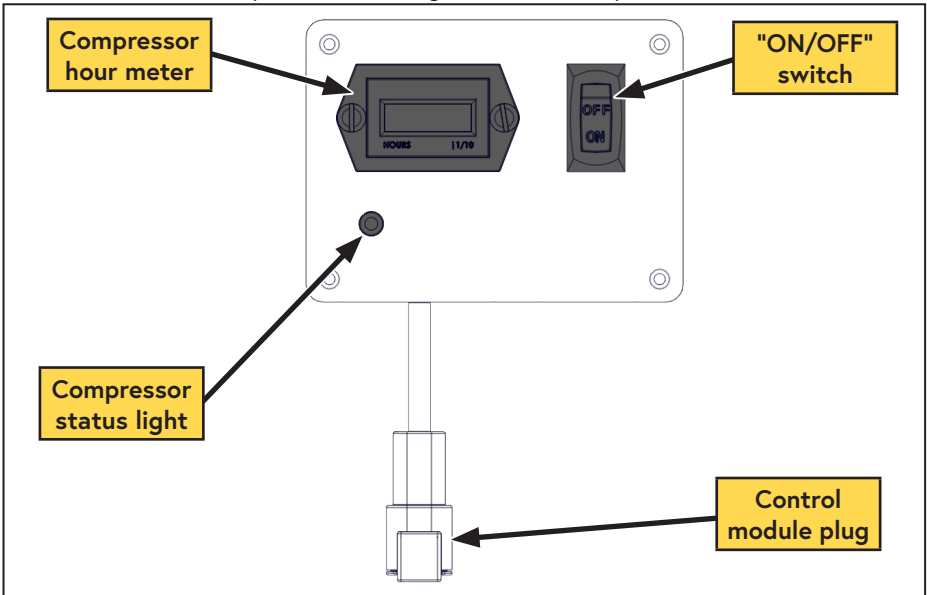

Figure 31 — Interface panel

Throttle Control (Figure 32)

The throttle control responds to signals from the control module and commands the vehicle's throttle to increase or decrease engine speed in response to air demand. The throttle control also allows the operator to configure the vehicle's engine speed (when air is demanded) to their needs (maximum cfm, specific tool requirements, fuel efficiency, or a combination of these factors).

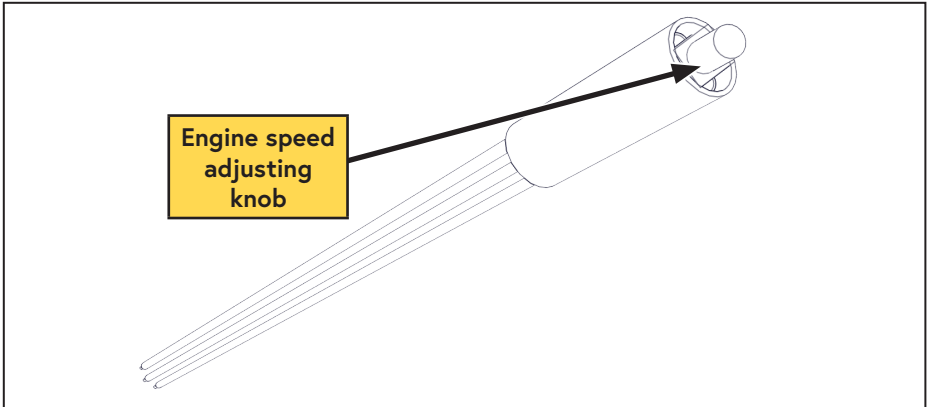

Figure 32 — VMAC throttle control

Mechanical Pressure Switch (Figure 33)

The mechanical pressure switch is mounted on the side of the WHASP Tank and limits the maximum pressure to a safe amount by disengaging the clutch once system pressure is achieved.

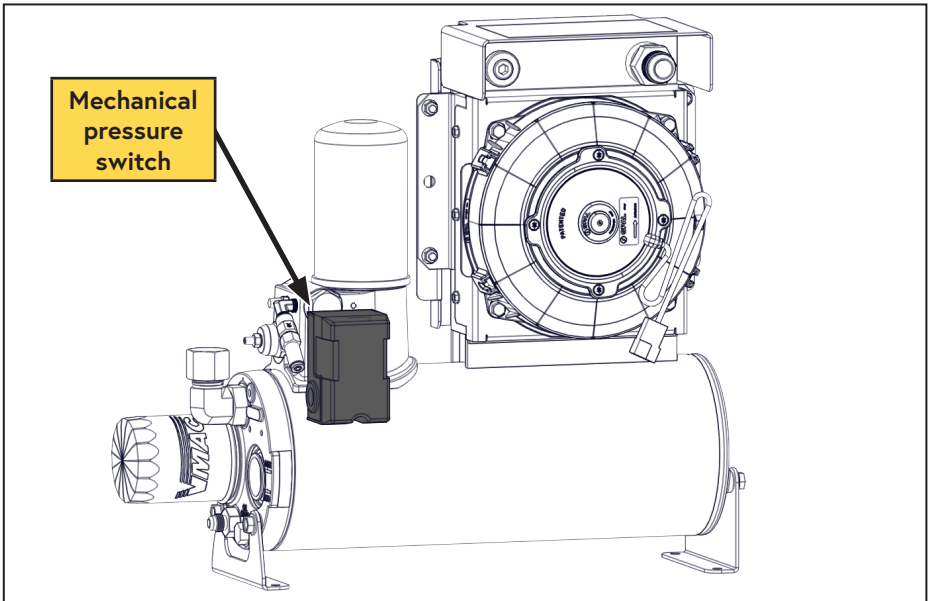

Figure 33 — WHASP Tank pressure switch

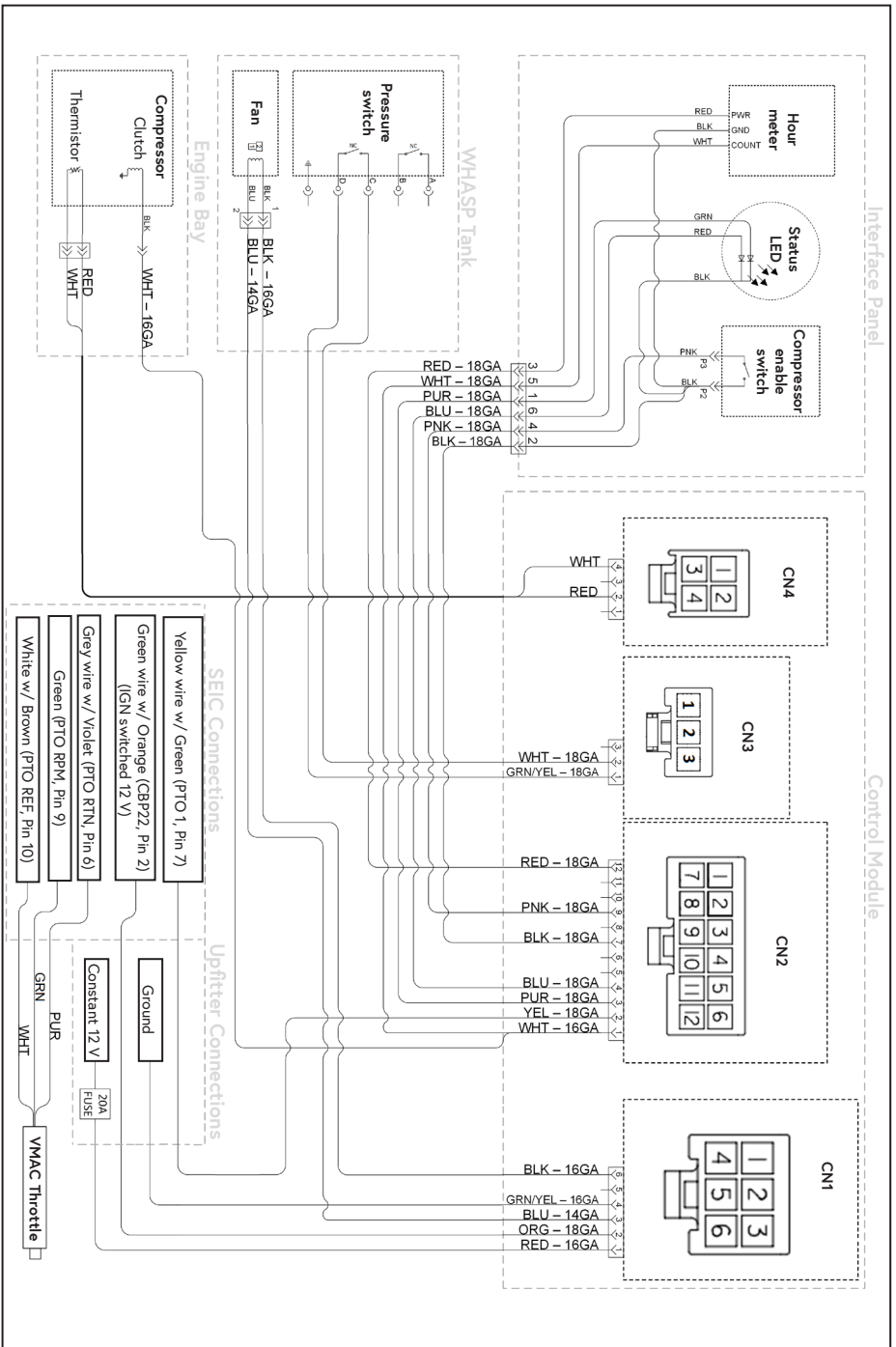

Figure 34 — Electrical schematic

Installing the Control Components

Throttle Control and Control Module

- Locate the OEM Stationary Elevated Idle Control (SEIC) interface connector pigtail behind the kick panel in the passenger side footwell (Figure 35).

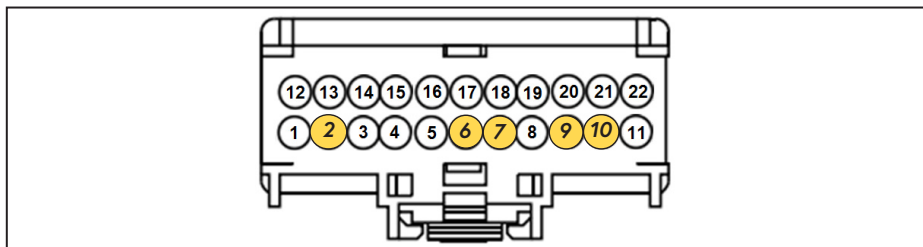

Figure 35 — SEIC interface connector

- Splice the purple wire from the throttle control to the grey wire with violet stripe at pin 6 (PTO RTN) of the SEIC pigtail.
 - Splice the green wire from the throttle control to the green wire at pin 9 (PTO RPM) of the SEIC pigtail.
 - Splice the white wire from the throttle control to the white wire with brown stripe at pin 10 (PTO REF) of the SEIC pigtail.
 - Splice the orange wire from the control module to the green wire with orange stripe at pin 2 (IGN switched 12 V CBP22) of the SEIC pigtail.
 - Splice the yellow wire from the control module to the yellow wire with green stripe at pin 7 (PTO 1) of the SEIC pigtail.
 - Position the throttle control in the SEIC cavity and secure it in place with cable ties.
 - Plug the 4 harnesses into the control module.
 - Mount the control module under the dashboard, up and out of the way of the pedals, steering column, and the park brake mechanism.
 - Connect the green ground wire from the control module to a good ground.
- Locate a grommet in the firewall and pass the following wires from the control module through to the engine bay*:
- *White 16 AWG wire with bullet connector from the control module (clutch wire).
 - *Grey cable with the green connector from the control module (temperature sensor).
 - *Red wire from the control module (constant power).
- Route the grey cable and white wire running from the control module with the compressor hoses installed earlier.
 - Connect the green connector on the grey cable to the matching connector on the compressor.
 - Connect the bullet connector on the white wire to the matching connector on the compressor.
 - Crimp the supplied fuse holder to the red wire running from the control module. Ensure the fuse holder is installed as close to the power source as possible.
 - Connect the other end of the fuse holder to the positive battery terminal.

VMAC - Vehicle Mounted Air Compressors

VMAC Technical Support: 888-241-2289

VMAC Knowledge Base: kb.vmacair.com

Interface Panel

- Install the interface panel in a suitable location (Figure 36).

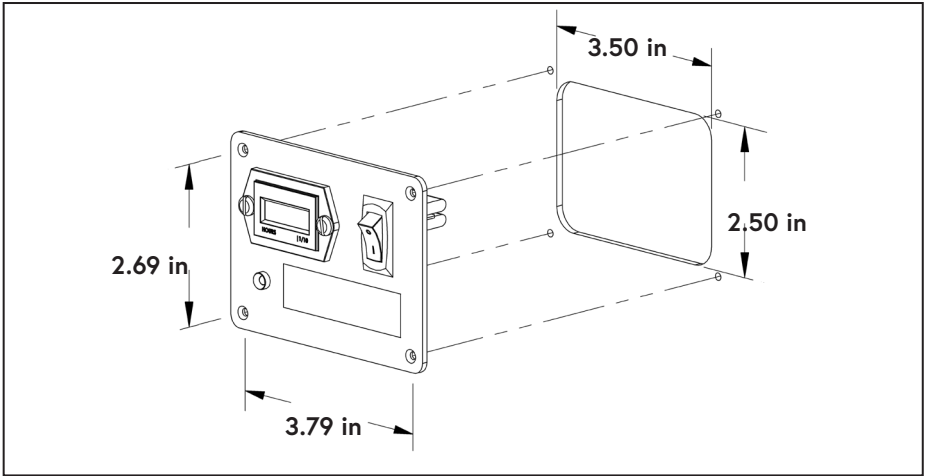

Figure 36 — Interface panel mounting dimensions

- Connect the harness from the control module to the interface panel.
- Connect the fan connector from the control module to the plug on the WHASP Tank.
- Remove the cover from the WHASP Tank pressure switch and connect the 2 ring terminals from the control module to the pressure switch on the WHASP Tank (not polarity dependent).
- Replace the cover when finished(Figure 37).

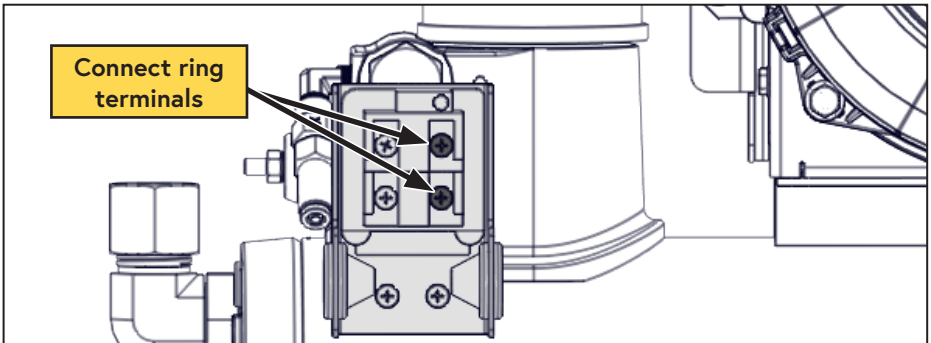

Figure 37 — Connect pressure switch



The WHASP Tank harnesses are made to a generic length. Any excess harness should be coiled up and secured out of the way. There are 2 extra ring terminals included with the pressure switch harness; if desired, cut the harness to length and crimp the spare ring connectors to it.

- Ensure all wires and harnesses are protected with loom and routed away from sharp, hot, or moving components and away from high traffic areas.

Completing the Installation

- Reinstall the fan stator.
- Reinstall the OEM fan and connect the wiring clip.
- Reinstall the fan shroud.
- Reinstall the coolant reservoir (if removed).
- Reinstall the OEM air intake tube.
- Replace any dashboard panels and other covers removed during installation.
- Connect the battery(s).
- Reinstall the reservoir onto the fan shroud and reconnect the secondary radiator hoses (if previously removed).
- Close the drain on the secondary radiator and fill with the coolant saved earlier in the installation (if previously drained).
- To alert any technicians that may service the vehicle, affix the servicing caution/contact label in the engine compartment near the hood latch in a visible location (Figure 38).



Figure 38 — Advisory label

- Install the belt routing label in the engine compartment near the hood latch in a visible location (Figure 39).

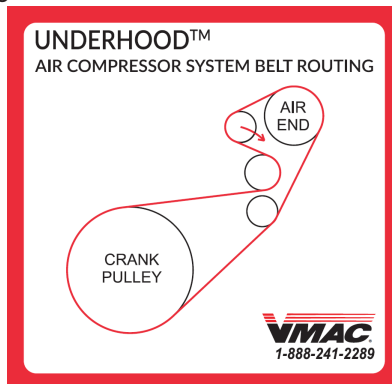

Figure 39 — Belt routing label
(actual belt routing label may differ)



The System Identification Plate must be attached to the vehicle at the time of installation. This plate provides information that allows VMAC to assist with parts and repairs.

- Locate a conspicuous area in the engine bay (where the tag will be easily noticed) to install the System ID tag.
- Mark and drill (x2) 7/64 in holes and secure the plate with the supplied self-tapping screws (Figure 40).



Figure 40 — System Identification Plate

- As part of the installation process, ensure that the safety and operational instruction decal is affixed in an obvious location so that it can be seen by vehicle operators. A good spot for this is usually on the inside of the door or on the panel underneath the steering wheel (Figure 41).



OPERATING INSTRUCTIONS

Daily Pre Start Check:

1. Check oil level in tank.
2. Check drive belt system.
3. Check for leaks.

Start Up Procedure:

1. Ensure air system is depressurized.
2. Ensure all air outlets are CLOSED.
3. Place vehicle in Neutral or Park and engage park brake.
4. Start engine and bring to operating temperature.
5. Turn ON compressor.

Shutdown Procedure:

1. Ensure discharge valve is CLOSED.
2. Allow engine to idle for 1 minute.
3. Turn OFF compressor.
4. Wait for system to depressurize before restarting.

For Technical Support/Parts contact your VMAC Dealer
To locate your nearest dealer call 1-800-738-8622 (250-740-3200)

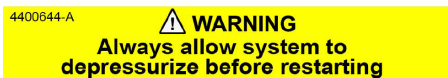

Figure 41 — Operating Instruction label

- Check all VMAC and OEM wiring to ensure it will not contact any hot, sharp or moving components and will not interfere with the operation of the vehicle. Secure all wiring with rubber coated P-clips, cable ties and loom as required.
- Check all VMAC and OEM hoses and tubes to ensure they will not contact any hot, sharp or moving components and will not interfere with the operation of the vehicle. Secure all hoses and tubes with rubber coated P-clips, cable ties and loom as required.

Air Receiver Tank



Pressure in the air receiver tank will not be relieved when the compressor system blows down. This is normal operation. Prior to performing any service work on the system, discharge any stored air in the air receiver tank.



The VMAC WHASP Tank has a built-in check valve. Use of an additional check valve is not required and may cause erratic performance.

The VMAC compressor system will automatically depressurize when it is shutdown. The WHASP Tank has a built in check valve which prevents blow back and moisture from the receiver tank entering the WHASP Tank. Installation of an additional check valve will cause erratic performance.

While the air receiver tank can be installed at any height in relation to the WHASP, the discharge hose running from the WHASP must be installed as high as possible on the air receiver tank to prevent problems with condensation that may have accumulated in the receiver tank (Figure 42).

Drain the condensed water from the receiver tank daily.

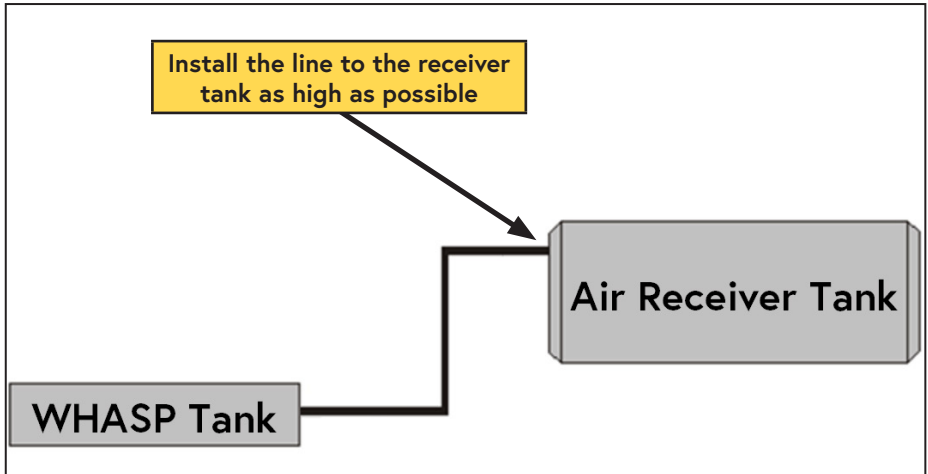

Figure 42 — Air receiver tank

Recommended Accessories

While the compressor system will function without the following accessories, VMAC strongly recommends their use for optimal performance.

See the "Accessory Product" section of this manual on page 44 for a list of products available for purchase through VMAC.

Larger Air Receiver Tank

A larger capacity air receiver tank provides a larger buffer as it gives the compressor time to react by increasing the engine speed and producing air before the tool stalls. It also has the advantage of lowering the duty cycle of the compressor system.

(This application requires a minimum air receiver tank size of 6 USG).

Pressure Gauge

While not critical to system performance, a pressure gauge is important for fine tuning the system and simplifies any potential troubleshooting. Install a 200 psi pressure gauge downstream of the air discharge valve.

Pressure Regulator and/or Lubricator or FRL

The compressor can produce air pressures up to approximately 150 psi (1035 kPa). It is the responsibility of the user to know the pressure and air flow requirements of the tools powered by the air compressor system.

An appropriate air pressure regulator and lubricator can be installed downstream of the air discharge valve. Failure to regulate the air pressure may cause damage to the tool.

Testing the Installation



Lift the vehicle, ensuring the driven wheels are off of the ground. Support the vehicle securely with appropriately rated jack stands. Ensure there are no people around the vehicle before beginning the test.

If the vehicle fails the test, ensure the wiring to all of the connections are correct and secure. If additional assistance is required, contact your local VMAC dealer or call VMAC Technical Support 1-888-241-2289 or 250-740-3200.

Safety Test

Ensure the following has been completed:

- Place the transmission in "PARK" and apply the park brake. Turn the ignition key to "ON" but do not start the engine.
- Turn on the compressor and listen for the compressor clutch to engage.
- Observe the hour meter, and ensure the hourglass icon is blinking.
- Turn off the compressor switch and ensure the clutch has disengaged.

Before Starting the Engine Checklist

Ensure the following has been completed:

- Check that the compressor oil level at the tank sight glass is correct.
- Complete a final inspection of the installation to ensure everything has been completed.
- Perform a final belt alignment check.
- Check all wiring for security and protection. Ensure nothing is touching the compressor body.
- Ensure all of the compressor outlets are closed.
- Ensure the parking brake is engaged and the transmission is in "PARK".
- Start the engine.

After Starting the Engine Checklist

- Allow the vehicle to reach operating temperature.
- Turn on the compressor. The compressor clutch should engage, and the engine speed should increase in response to the throttle control. The vehicle's tachometer should indicate approximately 2,000 rpm.
- Allow the compressor to run for approximately 10 seconds.
- Turn off the compressor.
- Shut down the engine.
- Check the compressor oil level after the engine has been shut down and the oil level has had time to stabilize.



Ensure any stored air is drained from the system prior to adding oil.

- Add oil as necessary to bring the level to the "FULL" line in the sight glass and check for leaks.
- Start the engine. Assistance may be required for the next steps.



The following tests confirm that the drive disable system is working correctly. The drive disable system prevents the VMAC throttle from increasing engine rpm unless the transmission is in "PARK" and the park brake is engaged.

2 people are required to perform this safety test. 1 person must remain in the driver seat and be prepared to actuate the service (foot) brake if necessary.

The second person will actuate the compressor switch and ball valve as necessary



To prevent engine damage, the Engine Control Module (ECM) will deactivate the SEIC system if any of the vehicle's parameters fall outside of normal operating specifications (including the park brake being released, depressing the service (foot) brake, or shifting the vehicle out of "PARK".

To reactivate the SEIC system, turn off the compressor, and ensure the SEIC enable conditions are met.

Refer to the Ford 2019 Body Builder Layout Book - SEIC/PTO or contact a Ford dealer for more information.

- Install the VMAC Air Test Tool (P/N: A700052) with the 40 cfm (5/32 in) orifice installed and the ball valve closed.
- With the engine running and the vehicle in "PARK", release the parking brake.
- Turn on the compressor and open the ball valve. The clutch should engage, but engine speed should NOT increase.
- Close the ball valve.
- Turn off the compressor.
- Reapply the park brake.
- With the service (foot) brake depressed, turn on the compressor and open the ball valve. The clutch should engage, but engine speed should NOT increase.
- Close the ball valve.
- Turn off the compressor.
- Drain any accumulated air from the system.
- Shift the transmission into "PARK".



Engine speed should not increase unless the vehicle is in "PARK" or "NEUTRAL".

- Ensure the parking brake is engaged.
- Turn on the compressor and open the ball valve.
- Release the park brake. The engine speed should drop to base idle.
- Reapply the park brake.
- Turn the compressor off and shut down the engine.
- Drain any accumulated air from the system.

Final Testing

Ensure the following has been completed:

- Operate the system with an air tool (or the VMAC Air Test Tool with the appropriate orifice installed) for at least 1/2 hour (1 hour preferred).



The WHASP Tank cooling fan is thermostatically controlled, and may start or stop without warning.

- Road test the vehicle for approximately 20 km (14 miles).
- Observe the compressor while it is operating to ensure the belts rotate properly, pulleys rotate smoothly and nothing is rubbing or contacting hot parts.
- Check all components, connections and fasteners once the engine is turned off and the system has cooled.
- Check the coolant level after the engine has been operated.
- Check the compressor oil level after the engine has been shut down and the oil level has had time to stabilize.



The VMAC throttle control is not tuned for maximum cfm output! For instructions on throttle adjustment and compressor performance testing, see the instructions starting on the next page.

Performance Testing and System Adjustments

Adjusting the Throttle Control

Adjustment is made by turning the adjustment knob. Turn the knob clockwise to increase engine speed and counterclockwise to decrease engine speed.

The throttle control is designed to provide 40 cfm when the throttle adjustment is at its maximum, this also prevents overspeeding the compressor.

Engine speed adjustments may be made so that the amount of air delivered by the system matches the requirements of the tools or equipment that will be used.

- This system achieves 40 cfm at 2,200 rpm.
- If the system is unable to "keep up" with a specific tool, the engine speed is too low. Try increasing the engine speed gradually, until the desired performance is obtained.
- If the system is cycling on and off rapidly when using a particular tool, the engine speed is likely higher than necessary for that tool. Try turning the engine speed down and observe the performance.



When testing the system or adjusting the VMAC throttle control, ensure the system does not exceed 2,400 engine rpm. Exceeding this speed will cause erratic system performance and in extreme cases may also cause long term damage to the compressor.

If the system is overspeeding, verify all wiring connections and retest. If the system continues to overspeed, contact VMAC Technical Support at 888-241-2289.

Compressor Performance Testing

This system has been adjusted at the factory for general operation, not maximum cfm. Any performance testing should be done with the throttle control set for maximum cfm. See the previous page for instruction on adjusting the throttle control.

System operation can be tested using the tools that will be operated by the system or by using the VMAC Test Tool (A700052) with the 40 cfm (5/32 in) orifice in the outlet to simulate tool use (Figure 43).

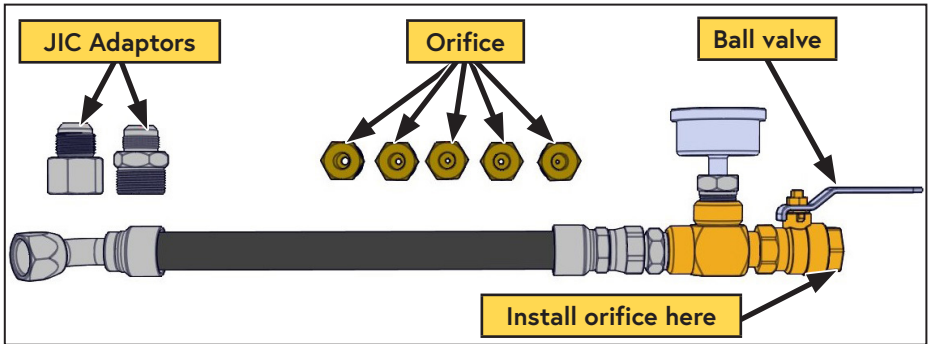

Figure 43 — A700052 VMAC Air Test Tool



Disconnect all downstream equipment (hose reels, etc.) and connect the test tool directly to the discharge fitting on the WHASP Tank. Ensure there are no leaks in the test tool. The system may not idle down if there are leaks in the lines or fittings.

- Install the VMAC test tool at the system outlet with the 40 cfm (5/32 in) orifice.
- Ensure the ball valve is closed.
- Place the transmission in "PARK" and fully apply the park brake.
- Allow the engine to run until it is at operating temperature.
- Turn on the air compressor system and allow it to operate until the oil is warm.
- Observe the pressure gauge. Pressure should be approximately 150 psi.
- Open the ball valve on the test tool and observe the engine tachometer. Engine speed should increase to approximately 2,200 rpm. The pressure on the gauge should be 90 - 120 psi.
- Close the air valve slowly to allow the system pressure to rise. When the pressure reaches the pressure switch set-point of 150 psi, the system will disengage the compressor clutch and reduce the engine speed to base idle.
- Once the system pressure is at maximum, slowly open the ball valve on the test tool until the pressure on the gauge begins to drop. Engine speed should ramp up to approximately 2,200 rpm when the pressure drops approximately 40 psi below the pressure switch set-point.

Accessory Products from VMAC

Compressor Service Kits



200 Hour or 6 Month Service Kit -

Part number: A700263

Includes 4 L VMAC high performance compressor oil, oil filter, air filter, and next service due decal.

400 Hour or 1-Year Service Kit -

Part number: A700264

Includes 4 L VMAC high performance compressor oil, oil filter, air filter, spin-on oil separator, safety valve, muffler, and next service due decal.

Bulkhead Fittings

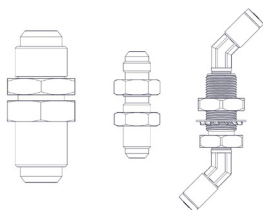

Part number: 3801095

Includes:

Bulkhead fittings are used for passing the system discharge, oil, and scavenge hoses through the floor or body panels.

- 3/4 in JIC bulkhead fitting P/N: 4900170.
- 3/8 in JIC bulkhead fitting P/N: 4900209.
- 1/8 in NPT bulkhead fitting P/N: 5000178.
- 2 x 45° 1/4 push-to-connect fittings P/N: 5000158.

Hose Fittings

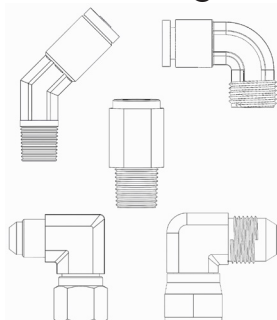

45° 1/4 push-to-connect fitting P/N: 5000158.

1/4 in push-to-connect fitting For PTFE scavenge tube.

90° 1/4 push-to-connect fitting P/N: 5000020.

1/4 in push-to-connect fitting For PTFE scavenge tube.

Straight 1/4 in push-to-connect fitting P/N: 5000012.

1/4 in push-to-connect fitting For PTFE scavenge tube.

90° 3/8 in hose fitting P/N: 4900117.

3/8 in hose fitting for Oil Return Hose.

90° 3/4 in hose fitting P/N: 4900043.

3/8 in hose fitting for Compressor Discharge Hose.

1/2 in x 50 ft Hose Reel

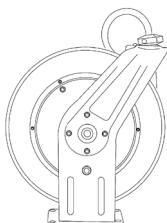

Part number: A700007

Spring-loaded 1/2 in x 50 ft hose reel; steel construction; full flow shaft and swivel for maximum performance.

6 Gallon Air Receiver Wing Tank

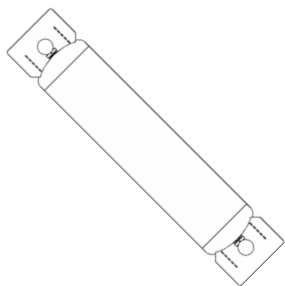

Part number: A300056

Air receiver tanks are used for lowering compressor duty cycle and removing water from compressed air; recommended for optimum operation of all VMAC Gas Driven, Diesel Driven, Hydraulic, and UNDERHOOD40 air compressors. Manufactured to FMVSS 121 standard; includes fittings, 170 psi pressure relief valve, and tank drain.

- Max pressure: up to 170 psi.
- Dimensions: 32 in (81.3 cm) L x 8 in (20.3 cm) D.
- Weight: 23 lb (10.4 kg).

10 Gallon Air Receiver Tank w/ Mounting Feet



Part number: A300047

Air receiver tanks are used for lowering compressor duty cycle and removing water from compressed air. Recommended for optimum operation of VMAC Hydraulic Air Compressors, VMAC Diesel Driven Air Compressors, UNDERHOOD40, UNDERHOOD70 – Green Series Air Compressors, and VMAC Multifunction Power Systems, which include standby mode; ASME certified; includes fittings, 200 psi pressure relief valve, tank drain, and 200 psi pressure gauge.

- Max pressure: up to 200 psi.
- Dimensions: 30 in (76.2 cm) L x 10 in (25.4 cm) D.
- Weight: 33 lb (15 kg).

35 Gallon Air Receiver Wing Tank

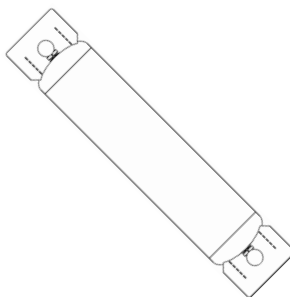

Part number: A300010

Air receiver tanks are used for lowering compressor duty cycle and removing water from compressed air. Recommended for optimum operation of VMAC Diesel Air Compressors, Hydraulic Air Compressors, UNDERHOOD40, UNDERHOOD70 – Green Series Air Compressors, and VMAC Multifunction Power Systems, which include standby mode; ASME certified; includes fittings, 200 psi pressure relief valve, tank drain, and 200 psi pressure gauge.

- Max pressure: up to 200 psi.
- Dimensions: 73 3/4 in (187.3 cm) L x 14 in (35.6 cm) D.
- Weight: 95 lb (43.1 kg).

UNDERHOOD 70 Air Aftercooler

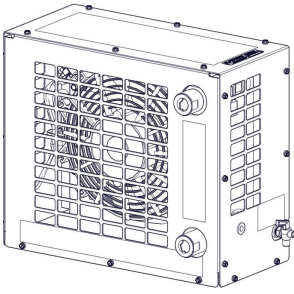

Part number: A800070

Improves tool performance and extends the life of air tools; removes up to 80% of water from compressed air; includes automatic water drain.

- Max air flow: 70 cfm / 175 psi.
- Port size: 3/4 in NPT inlet and outlet.
- Electrical: 12 V.
- Dimensions: 17 in (43.2 cm) L x 8.0 in (20.3 cm) W x 14.5 in (36.8 cm) H .
- Weight: 35 lb (15.8 kg).

Filter Regulator Lubricator (FRL) – 70 cfm

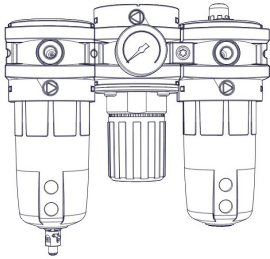

Part number: A700151

Extends the life of air tools; filter removes contaminants from the compressed air, adjustable regulator can reduce air pressure going to tools, lubricator adds atomized tool oil to the air stream to lubricate air tools (Tool oil not included).

- Max air flow: up to 70 cfm / 150 psi.
- Port size: 3/4 in NPT inlet and outlet.

Remote Muffler

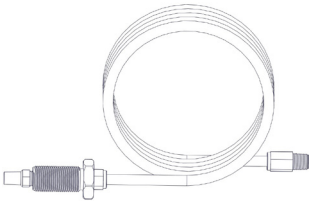

Part number: A700224

The A700224 WHASP remote mount muffler kit is designed to relocate the blowdown muffler to an external location. This is recommended for applications where the WHASP Tank will be located inside of a van or service body, the remote mounted muffler will reduce cabin noise when the compressor blowdown operates, and will ensure any oil vapor will be safely discharged outside of the vehicle.

Interface Harness Extension

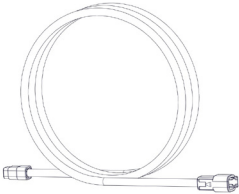

Part number: A700265

This interface harness extension provides an additional 10 ft of cable which allows for greater flexibility in locating the Interface Panel.

Warranty Registration

This form must be fully completed and returned to VMAC at the time the vehicle is put into service. Warranty may be void if this form is not received by VMAC within 3 months of receiving the vehicle, or 200 hours of operation, whichever occurs first.



VMAC's Warranty policy and registration can be viewed online at:

www.vmacair.com/warranty

Product Information

System Identification Number: **V** _____

Compressor Serial Number: **P** _____

Owner / End User Information

Company Name: _____

City: _____ State / Province: _____

Phone: (____) ____-_____

Email Address: _____

Date vehicle was put into service: ____/____/____
Day Month Year

Installer Information

Installer Company Name: _____

City: _____ State / Province: _____

Submitted by

Name: _____ Phone: (____) ____-_____

Email: _____

Vehicle Information (Optional)

Unit: _____ Year: _____

Make: _____ Model: _____

Vehicle Identification Number: _____

Manufactured by



888-241-2289



tech@vmacair.com



877-740-3202



warranty@vmacair.com



www.vmacair.com



kb.vmacair.com



1333 Kipp Road, Nanaimo, B.C., V9X 1R3 Canada