

UNDERHOOD[™] **40** AIR COMPRESSORS



Installation Manual for VMAC System

V400007

2011 – 2019 GMC Sierra and Chevrolet Silverado

2500 – 3500

4.8 L / 5.3 L / 6.0 L V8 Gas

www.vmacair.com

Table of Contents

Safety	3
Warranty	4
General Information	6
System Identification, Warranty Registration and Warning Labels.....	8
Preparing for Installation	10
Installing the Main Bracket and Compressor	18
Installing the Waste Heat Air Separator Package (WHASP) Tank.....	23
Hose Requirements	26
Connecting the Hoses	27
Adding Oil to the System	29
Installing the Control System	30
Air Receiver Tank	42
Recommended Accessories	43
Completing the Installation	44
Testing the Installation	45
Performance Testing and System Adjustments	48
Accessory Products from VMAC	50
Warranty Registration	56

Revision	Revision Details	Revised by	Checked by				Implemented
			Eng.		Tech.	Qual.	
			Mech.	Elec.			
B	ECN: 20-210 Receiver tank requirement	MSP	MRH	N/A	MSP	N/A	2 Nov. 2020
C	ECN: 22-009 Cap model year	MSP	N/A	N/A	MSP	N/A	27 May 2022

Additional Application Information

- Use of an air receiver tank (minimum 6 USG) is required with this application.
- 2011 - 2019 GMC Sierra and Chevrolet Silverado 2500 - 3500 4.8 L / 5.3 L 6.0 L V8 Gas.

Registered Trademarks

All trademarks mentioned in this manual are the property of their respective owners. VMAC's use of manufacturers' trademarks in this manual is for identification of the products only and does not imply any affiliation to, or endorsement of said companies.

Torx® is a registered trademark of Acument Intellectual Properties, LLC

Nylok® is a registered trademark of Nylok Fastener Corporation.

Lisle® is a registered trademark of the Lisle Corporation.

Loctite®, Loctite® 242 and **Loctite® 567** are registered trademarks of Henkel AG & Company KGaA.

Eaton Aeroquip® is a registered trademark of EATON AEROQUIP INC.

GM®, GMC® and **Chevrolet®** are registered trademarks of General Motors Company LLC.

Important Information

The information in this manual is intended for certified VMAC installers who have been trained in installation and service procedures and/or for anyone with mechanical trade certification who has the tools and equipment to properly and safely perform the installation or service. Do not attempt installation or service without the appropriate mechanical training, knowledge and experience. Follow all safety precautions. Any fabrication for correct fit in modified vehicles must follow industry standard "best practices".

Notice

Copyright © 2020 VMAC Global Technology Inc. All Rights Reserved. These materials are provided by VMAC for informational purposes only, without representation or warranty of any kind, and VMAC shall not be liable for errors or omissions with respect to the materials. The only warranties for VMAC products and services are those set forth in the express warranty statements accompanying such products and services, if any, and nothing herein shall be construed as constituting an additional warranty. Printing or copying of any page in this document in whole or in part is only permitted for personal use. All other use, copying or reproduction in both print and electronic form of any part of this document without the written consent of VMAC is prohibited. The information contained herein may be changed without prior notice.

Printed in Canada

Safety

Important Safety Notice

The information contained in this manual is based on sound engineering principles, research, extensive field experience and technical information. Information is constantly changing with the addition of new models, assemblies, service techniques and running OEM changes. If a discrepancy is found in this manual, contact VMAC Technical Support prior to initiating or proceeding with installation, service or repair. Current information may clarify the issue. Anyone with knowledge of such discrepancies, who proceeds to perform service and repair, assumes all risks.

Only proven service procedures are recommended. Anyone who departs from the specific instructions provided in this manual must first ensure that their safety and that of others is not being compromised, and that there will be no adverse effects on the operational safety or performance of the equipment.

VMAC will not be held responsible for any liability, consequential damages, injuries, loss or damage to individuals or to equipment as a result of the failure of anyone to properly adhere to the procedures set out in this manual or standard safety practices.

Safety should be the first consideration when performing any service operations. If there are any questions concerning the procedures in this manual, or more information is required, please contact VMAC Technical Support prior to beginning work.

Safety Messages

This manual contains various warnings, cautions and notices that must be observed to reduce the risk of personal injury during installation, service or repair and the possibility that improper installation, service or repair may damage the equipment or render it unsafe.



This symbol is used to call attention to instructions concerning personal safety. Watch for this symbol; it points out important safety precautions, it means, "Attention, become alert! Your personal safety is involved". Read the message that follows and be aware of the possibility of personal injury or death. As it is impossible to warn of every conceivable hazard, common sense and industry standard safety practices must be observed.



This symbol is used to call attention to instructions on a specific procedure that if not followed may damage or reduce the useful life of the compressor or other equipment.



This symbol is used to call attention to additional instructions or special emphasis on a specific procedure.

Warranty

VMAC Standard Warranty (Limited)

For complete warranty information, including both VMAC Standard Warranty (Limited) and VMAC Lifetime Warranty (Limited) requirements, please refer to our current published warranty located at: www.vmacair.com/warranty



If you do not have access to a computer, please contact us and we will be happy to send you our warranty.

VMAC's warranty is subject to change without notice.

VMAC Lifetime Warranty (Limited)

A VMAC Lifetime Limited Warranty is offered on the base air compressor only and only on UNDERHOOD, Hydraulic Driven, Transmission Mounted, Gas and Diesel Engine Driven Air Compressors, Multifunction Power Systems, and other products as defined by VMAC, provided that (i) the purchaser fully completes and submits a warranty registration form within 3 months of purchase, or 200 hours of operation, whichever occurs first; (ii) services are completed in accordance with the Owner's Manual; (iii) proof of purchase of applicable service kits are made available to VMAC upon request.



The VMAC Lifetime Warranty is applicable to new products shipped on or after 1 October, 2015.

Warranty Registration

The VMAC warranty registration form is located near the back of this manual. This warranty registration form must be completed and sent to VMAC at the time of installation for any subsequent warranty claim to be considered valid.

There are 4 ways the warranty can be registered with VMAC:



www.vmacair.com/warranty



warranty@vmacair.com



(877) 740-3202



VMAC - Vehicle Mounted Air Compressors
1333 Kipp Road, Nanaimo, BC, Canada V9X 1R3

VMAC Warranty Claim Process



VMAC warranty work must be pre-authorized by VMAC. Claims are processed via our dealer network. If you are not a VMAC dealer, please select one to work with via our Dealer Locator: <https://www.vmacair.com/dealer-locator/>



1. Communicate with VMAC Technical Support at 1-888-241-2289 or tech@vmacair.com to help diagnose/troubleshoot the problem prior to repair. VMAC technical support will require the VMAC System ID, hours on the compressor and mileage on the vehicle.
2. VMAC will provide direction for repair or replacement of the failed components.
3. If requested, failed parts must be returned to VMAC for evaluation.
4. Dealers may login to the VMAC website to view the "VMAC Labour Time Guide" (under "Agreements") to see the allowable warranty labour times.
5. Warranty invoices must include the Service Ticket number, VMAC System ID#, hours on the compressor, and a detailed description of the work performed.
6. VMAC Warranty does not cover consequential damages, overtime charges, mileage, travel time, towing/recovery, cleaning or shop supplies.
7. Dealers submit warranty claims on behalf of the Vehicle Owner/End User affected by the defective part(s). The dealer ensures that all warranty credits are refunded back to the Vehicle Owner/End User who made the initial warranty claim.



In order to qualify for Lifetime Warranty (Limited), the completed warranty registration form must be received by VMAC within 3 months of the buyer receiving the Product(s), or 200 hours of operation, whichever occurs first.

If the completed warranty registration form has not been received by VMAC within 3 months of the buyer receiving the Product(s), or 200 hours of operation, the warranty period will be deemed to commence 30 days from the date of shipment from VMAC.

Failure to follow the warranty claim process may result in denial of the warranty claim.

VMAC Product Warranty Policies & Warranty Registration can be found on the VMAC website (see previous page for URL).

General Information

Optional Equipment Compatibility

While VMAC strives to design systems compatible with optional OEM equipment (such as running boards), it is impractical to develop systems that accommodate every OEM and aftermarket option or add-on. Whenever possible, VMAC endeavors to advise of compatibility issues in the "Additional Application Information" section of the manual. Even when specific optional equipment is determined by VMAC to be incompatible, it does not preclude the vehicle upfitter or end user from modifying the optional equipment to make it compatible with the installed VMAC system. VMAC does not warranty or accept responsibility or liability for the fitment, function or safety of any products modified in any way not expressly outlined in the installation manual.

Before Starting



Note and label all parts that are removed from the vehicle as many of the OEM parts will be reused during the installation of the VMAC system.

Read this manual prior to beginning the installation to ensure familiarity with the components and how they will fit on the vehicle. Identify any variations from the application list such as vehicle model, engines, or optional equipment (e.g., dual alternator, active steering assist, etc.).

Open the package, unpack the components and identify them using the Illustrated Parts List (IPL) included in the Fastener Pack.

Hose Information

Depending on other installed equipment, it might be necessary to move the air/oil separation tank from its intended location. The hoses used in VMAC compressor systems have a specific inner liner that is compatible with VMAC compressor oil. Use of hoses other than those supplied or recommended by VMAC may cause compressor damage and may void your warranty. Please contact VMAC for replacement hoses and further information.

Ordering Parts

To order parts, contact a VMAC dealer. The dealer will ask for the VMAC serial number, part number, description and quantity. Locate the nearest dealer online at www.vmacair.com/dealer-locator or call 1-877-912-6605.



Special Tools Required

- Pneumatic fan wrench removal set (such as Lisle® 43300) or a manual fan pulley holder (such as KD Tool® KD3900).
- 6 mm hex ball end extended socket.

Torque Specifications

All fasteners must be torqued to specifications. Use manufacturers' torque values for OEM fasteners.

The torque values supplied in Table 1 are intended for VMAC supplied components, or for use as a guide in the absence of a torque value provided by an OEM.



Apply Loctite 242 (blue) to all fasteners (except nylon lock nuts) unless otherwise stated.

Torque values are with Loctite applied unless otherwise specified.

Standard Grade 8 National Coarse Thread								
Size (in)	1/4	5/16	3/8	7/16	1/2	9/16	5/8	3/4
Foot pounds (ft•lb)	9	18	35	55	80	110	170	280
Newton meter (N•m)	12	24	47	74	108	149	230	379

Standard Grade 8 National Fine Thread					
Size (in)	3/8	7/16	1/2	5/8	3/4
Foot pounds (ft•lb)	40	60	90	180	320
Newton meter (N•m)	54	81	122	244	434

Metric Class 10.9						
Size (mm)	M6	M8	M10	M12	M14	M16
Foot pounds (ft•lb)	4.5	19	41	69	104	174
Newton meter (N•m)	6	25	55	93	141	236

Table 1 — Torque Table

System Identification, Warranty Registration and Warning Labels



Preparation for installation is very important. Missing a step or an item can cause problems in the installation or damage to components.

Check off each item as it is completed so that no steps are missed.

- Review the contents of the system using the illustrated parts list to ensure all components are present and in the correct quantity. If any components are missing, have the system ID ready and call VMAC Technical Support at (888) 241-2289.



The VMAC warranty form must be completed and returned to VMAC at the time of installation for any subsequent warranty claim to be considered valid.

- Complete the warranty form. The VMAC warranty form is located at the back of this manual, as well as online at: www.vmacair.com/warranty



The System Identification Plate must be attached to the vehicle at the time of installation. This plate provides information that allows VMAC to assist with parts and repairs.

- Mark and drill 2 × 7/64 in holes in the top of the cross member in front of the hood support. Secure the plate with the supplied self-tapping screws (Figure 1).



Figure 1 — System Identification Plate

- Install the VMAC belt routing diagram in a suitable location under the hood.

- As part of the installation process, ensure that the safety and operational instruction decal is affixed in an obvious location so that it can be seen by vehicle operators. A good spot for this is usually on the inside of the door or on the panel underneath the steering wheel (Figure 2).

VMAC
VEHICLE MOUNTED AIR COMPRESSORS

This vehicle is equipped with a
VMAC Air Compressor System.

OPERATING INSTRUCTIONS

Daily Pre Start Check:

1. Check oil level in tank.
2. Check drive belt system.
3. Check for leaks.

Start Up Procedure:

1. Ensure air system is depressurized.
2. Ensure all air outlets are CLOSED.
3. Place vehicle in Neutral or Park and engage park brake.
4. Start engine and bring to operating temperature.
5. Turn ON compressor.

Shutdown Procedure:

1. Ensure discharge valve is CLOSED.
2. Allow engine to idle for 1 minute.
3. Turn OFF compressor.
4. Wait for system to depressurize before restarting.

For Technical Support/Parts contact your VMAC Dealer
To locate your nearest dealer call 1-800-738-8622 (250-740-3200)

4400644-A

⚠ WARNING
Always allow system to depressurize before restarting

Figure 2 — Operating Instruction label

- To alert any technicians that may service the vehicle, affix the servicing caution/contact label in the engine compartment near the hood latch in a visible location (Figure 3).

⚠

VMAC
VEHICLE MOUNTED AIR COMPRESSORS

1-888-241-2289
(250) 740-3200

This vehicle is equipped with a VMAC Air Compressor System. Call VMAC Technical Support for removal/installation information.

4401017A

Figure 3 — Advisory label

Preparing for Installation



Due to the variety of possible WHASP tank installation locations, VMAC does not include bulkhead fittings or hoses to run between any bulkhead and the WHASP tank. VMAC recommends determining where the WHASP tank will be located early in the installation so that appropriate hose lengths and bulkhead fittings can be ordered. Refer to page 23 for WHASP tank installation requirements.



Ensure the VMAC Warranty Registration has been filled out and the System Identification Plate and Operating Instruction Label are installed prior to proceeding (Please see page 8 for details).



Do not use a test light to probe for power on vehicle circuits, the increased current draw of the test light may damage components.



2011 - 2014 trucks have different wire colours than 2015 and newer trucks, pay close attention to model year and wire colours.

- Locate the Engine Control Module (ECM) on the driver side fender near the brake fluid reservoir (Figure 4).

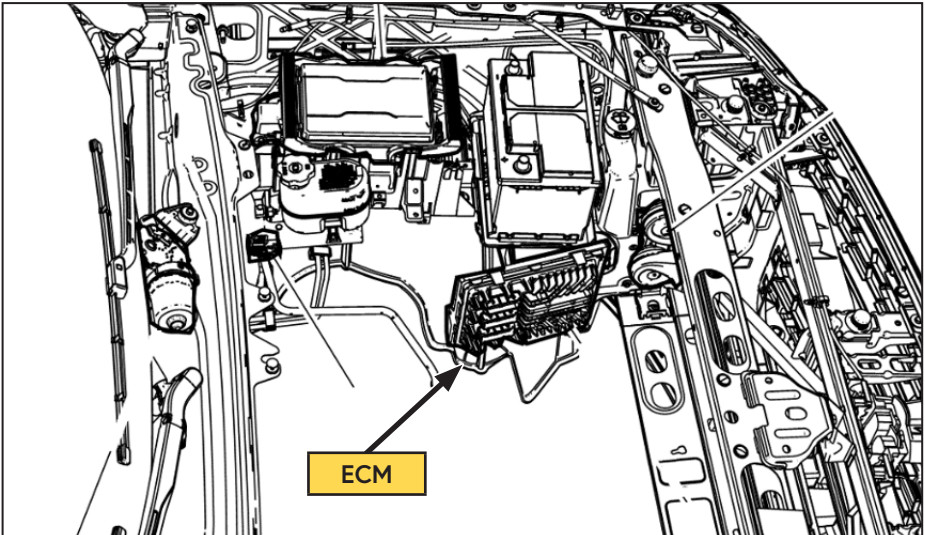

Figure 4 — ECM location

- Remove the electrical tape and peel back the plastic loom for the X1 connector (the smallest connector at the top of the ECM) and the X2 connector (the larger connector beside X1).

Model Year 2011 – 2014 ECM X1 Connector



There are 2 orange wires with black stripe in the ECM X1 bundle. Follow the test below to determine the correct wire.

- Locate the orange wire with black stripe going to pin 34 in the ECM X1 connector (Figure 5).

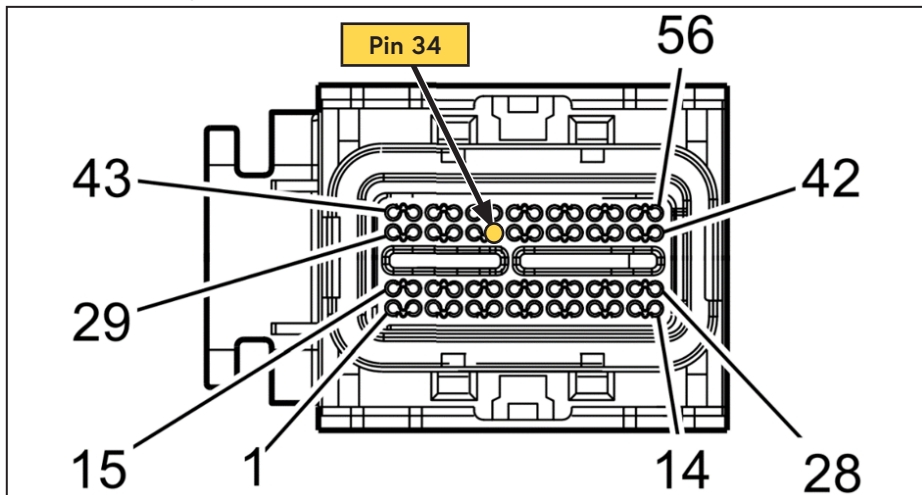

Figure 5 — ECM connector X1 (connector "face" view)

- Turn the ignition to "RUN" but do not start the vehicle. Use a multimeter to verify the correct wire. The correct wire will show 0 V in "PARK" or "NEUTRAL" and 12 V in all other gear selector positions.
- Turn the ignition switch to "OFF". Mark the correct wire for electrical connections later in the installation process.

Model Year 2015+ ECM X1 Connector



There are 2 white wires with grey stripe in the ECM X1 bundle. Follow the test below to determine the correct wire.



The X1 connector needs to be plugged into the ECM to test the voltage.

- Locate the white wire with the grey stripe going to pin 34 in the ECM X1 connector (Figure 6).

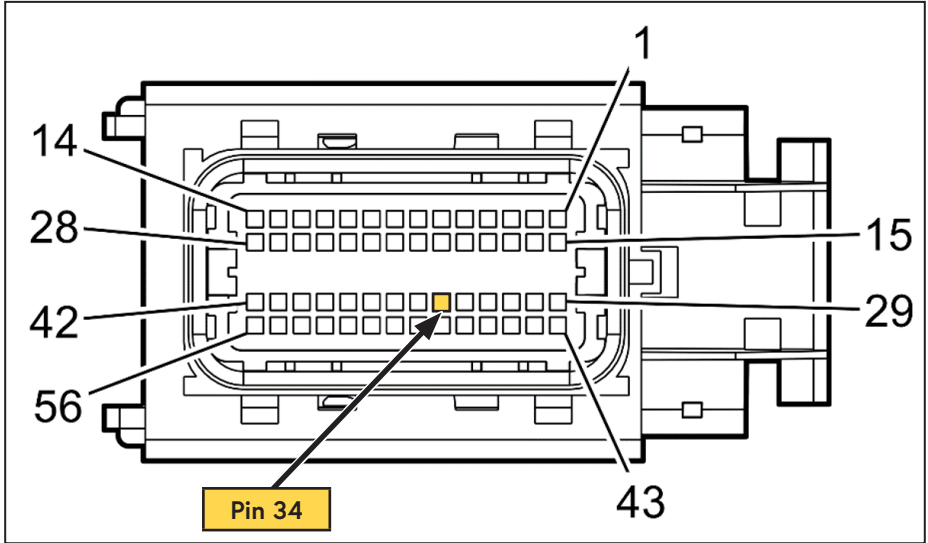

Figure 6 — 2015+ ECM Connector X1

- Turn the ignition to "RUN" but do not start the vehicle. Use a multimeter to verify the correct wire. The correct wire will show 0 V in "PARK" or "NEUTRAL" and 12 V in all other gear selector positions.
- Turn the ignition switch to "OFF". Mark the correct wire for electrical connections later in the installation process.

ECM X2 Connector (All model years)



There are 2 light green wires in the ECM X2 bundle. Follow the test below to determine the correct wire.

- Cut any tape or loom bundling the wires of the X2 ECM connector (larger connector beside X1).
- Locate the 2 light green wires in the X2 ECM connector. (Figure 7).

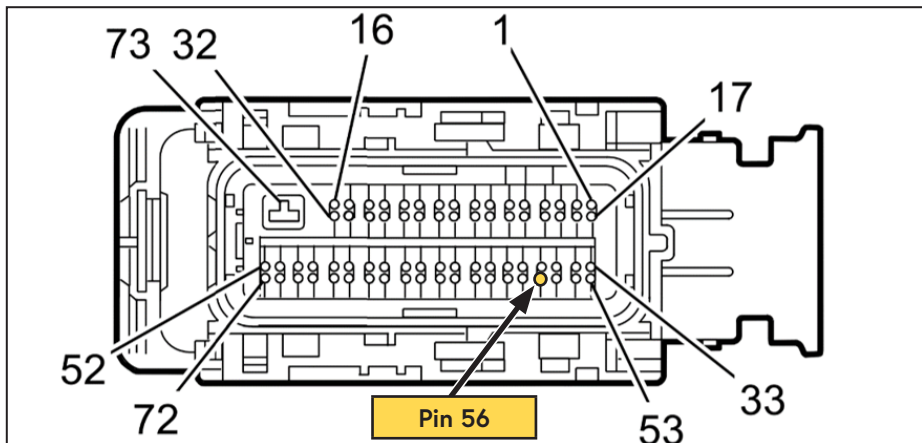

Figure 7 — ECM connector X2 (connector "face" view)

- Start the vehicle and allow the rpm to settle to idle.
- Use a multimeter to verify the correct wire. The correct wire will show a stable voltage reading of 2.3 V - 2.8 V while the engine is idling.
- Turn the ignition switch to "OFF". Mark the correct wire for electrical connections later in the installation process.
- 2011 – 2014 only.** Remove the fuse panel cover. Turn the ignition switch to "RUN" and using a multimeter, locate an ignition switched fuse.
- 2011 – 2014 only.** Remove the fuse and using the multimeter, make a note of which side is the supply/hot side and which side is the fused side.
- Replace the fuse.
- Disconnect and cover the battery terminals.

Optional: Raise the front of the vehicle and support on axle stands (if the vehicle is raised, ensure it is adequately supported on axle stands).

- Disconnect the support clips on the upper radiator hose and the wiring loom running over the top of the fan shroud.
- Remove the upper fan shroud. There are 2 bolts on the top and 3 bolts on each side of the shroud.
- Remove the Front End Accessory Drive (FEAD) belt and retain it in the vehicle. In the unlikely event of a compressor failure, the VMAC belt can be removed and the OEM belt can be reinstalled to operate the vehicle.
- Disconnect the power wire from the alternator.
- Disconnect the 3 wire electrical connector from the alternator.
- Remove the 2 alternator bolts and remove the alternator. Set them aside for reinstallation later (Figure 8).

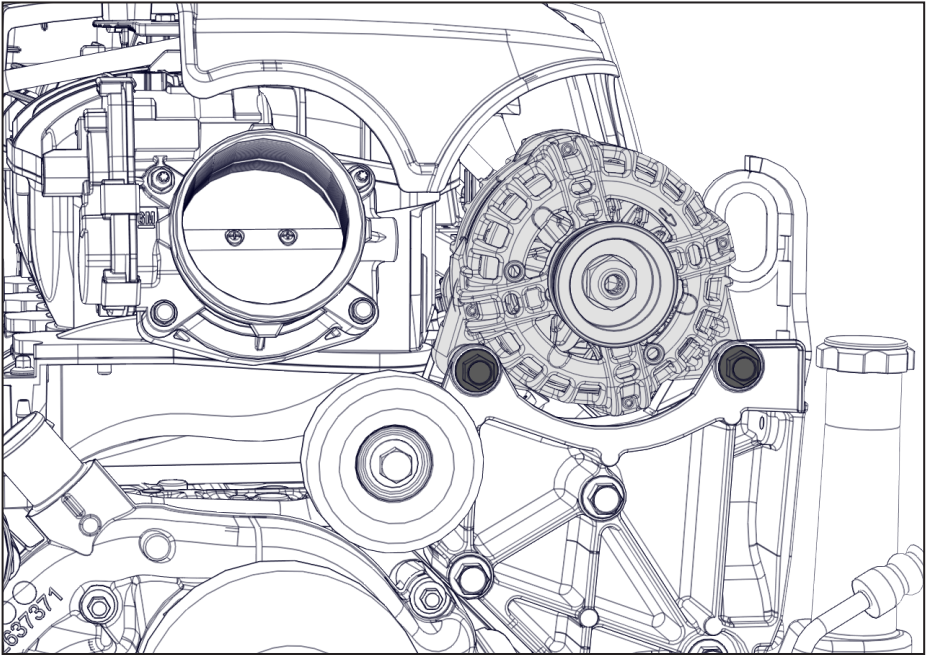

Figure 8 — Remove alternator

- Remove the OEM idler from the top of the bracket and set it aside for reinstallation later (Figure 9).

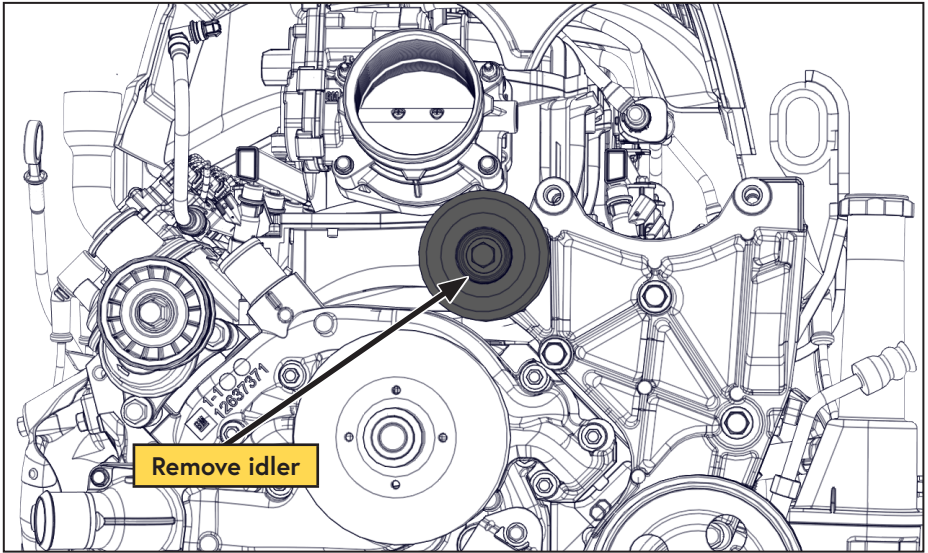

Figure 9 — Remove idler



Leave the power steering hoses connected to the power steering pump and secure the pump out of the way.

- Remove the 3 power steering pump bolts (the bolts can be accessed through the holes in the pulley). Retain the bolts for reinstallation later (Figure 10).

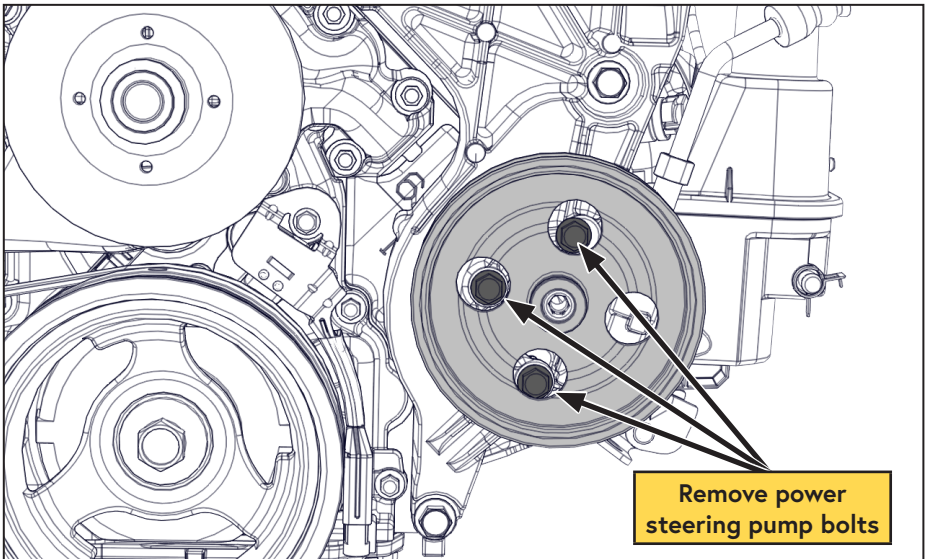

Figure 10 — Remove power steering pump

- Remove the 4 OEM alternator / power steering bracket bolts and remove the bracket. Retain the bolts for reinstallation later (Figure 11).

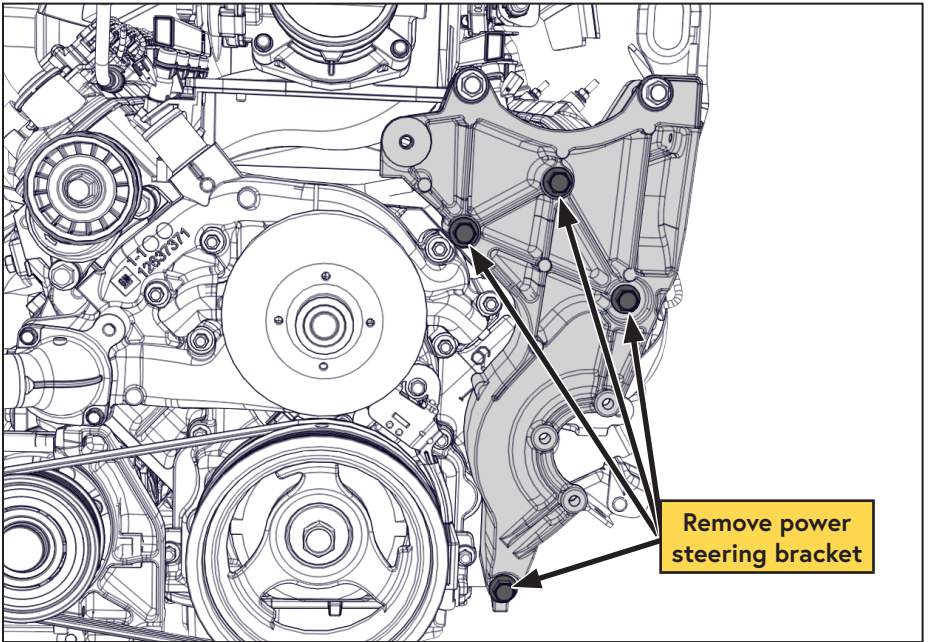

Figure 11 — Accessory bracket removal

- Remove the bushings from the OEM bracket (Figure 12).

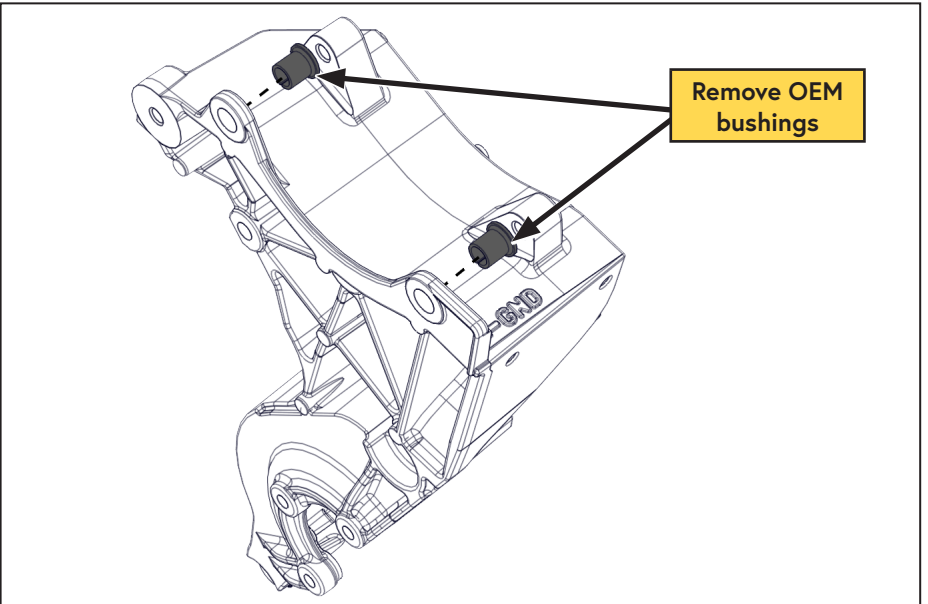

Figure 12 — Bracket bushing removal

- Remove the idler installed on the VMAC bracket.
- Install the 2 OEM bushings, and the 2 supplied dowels into the VMAC main bracket (Figure 13).

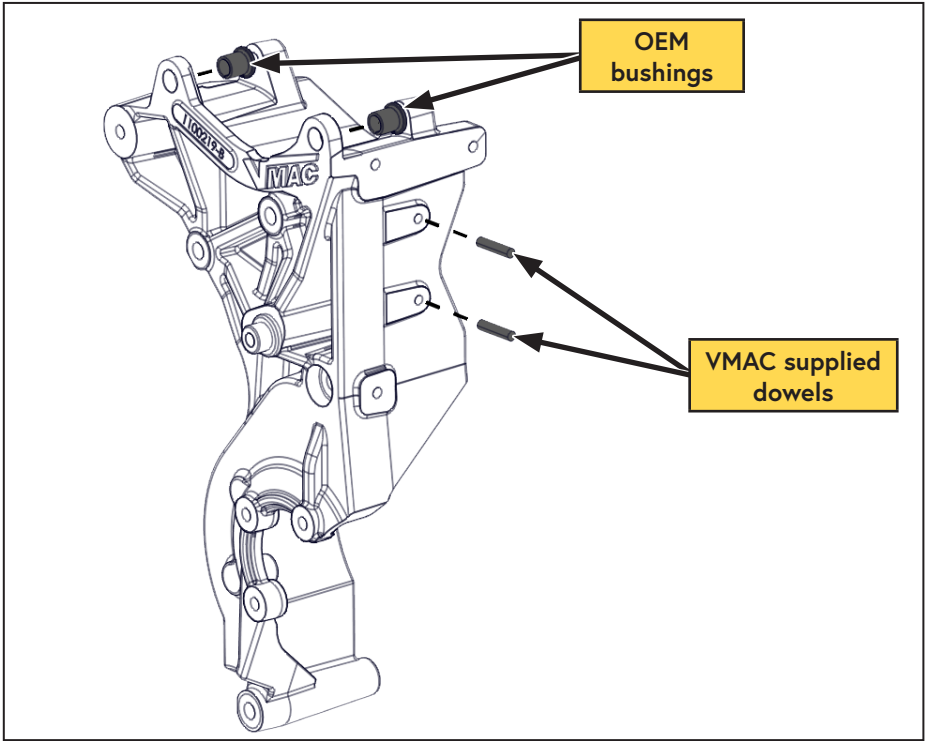

Figure 13 — VMAC bracket bushing and dowel installation

Installing the Main Bracket and Compressor



Apply Loctite 242 (blue) to all engine mounted fasteners.

- Install the VMAC main bracket in the location shown and torque the fasteners to specification (Figure 14).

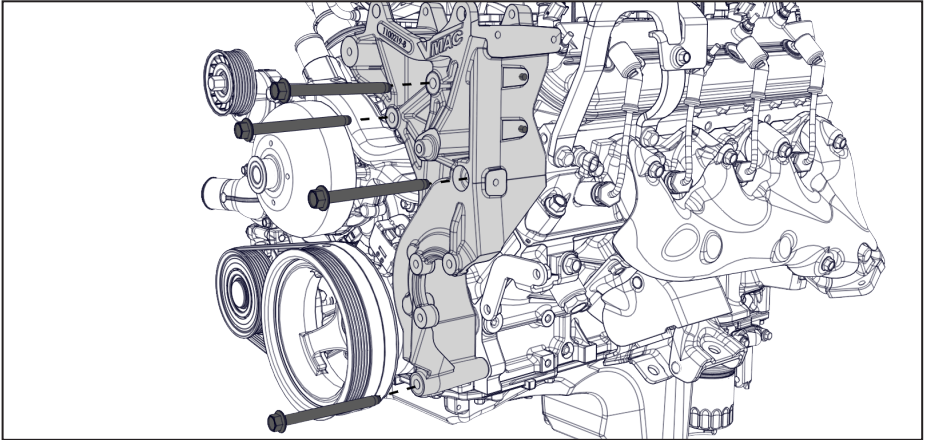

Figure 14 — Main bracket installation

- Install the OEM idler in the original position on the VMAC bracket (Figure 15).

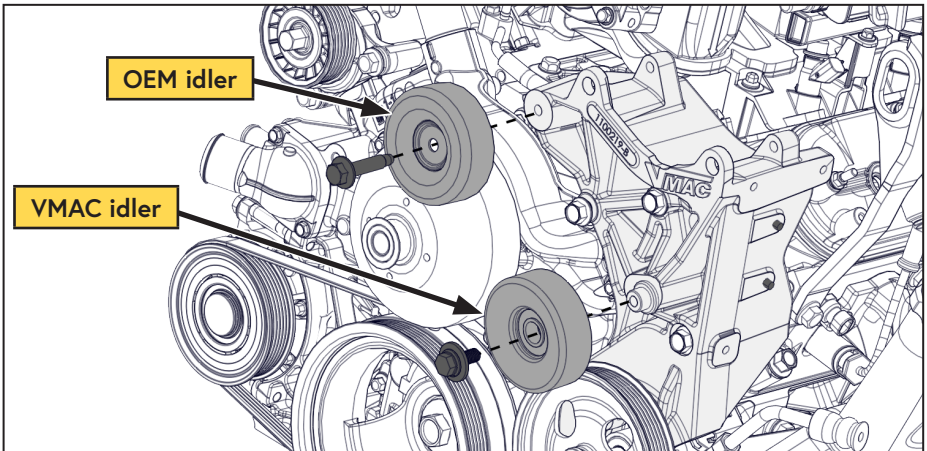

Figure 15 — Installing FEAD components

- Install the VMAC idler onto the VMAC bracket (Figure 15).
- Install the OEM alternator using the OEM bolts. Connect the power wire, and the 3 wire electrical connector.



There are 2 dowels on the side of the VMAC bracket, these are used to locate the compressor in the correct position for bolt installation and belt alignment.

- Position the compressor on the 2 dowels on the VMAC bracket.
- Install the 3 compressor bolts (Figure 16).

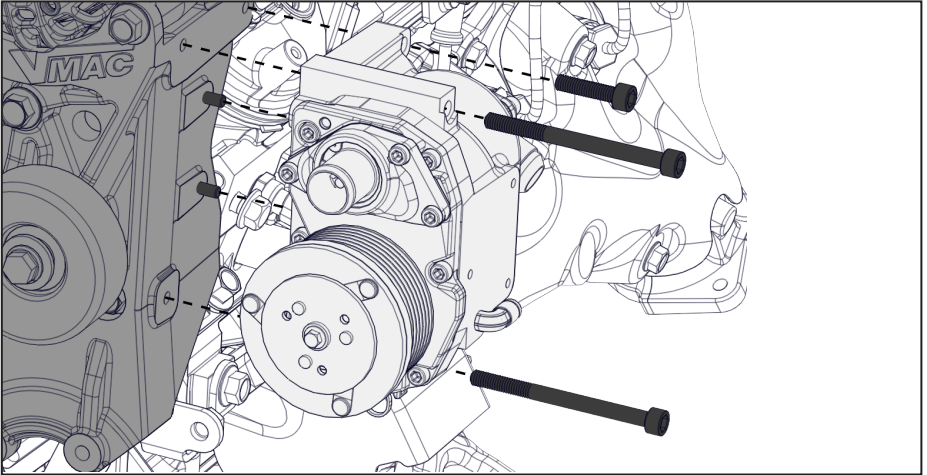

Figure 16 — Compressor installation

- Connect the straight end of the supplied longer 3/8 in hose to the matching fitting on the side of the VMAC compressor and tighten the fitting. The remainder of the hose installation will be covered later in the installation.
- Install the air filter bracket onto the compressor (Figure 17).

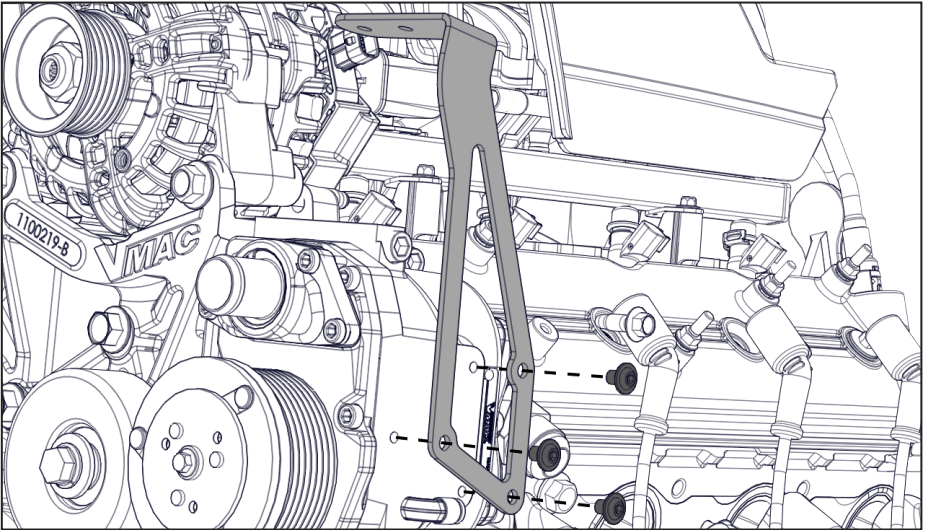

Figure 17 — Air filter bracket

- Install the power steering pump onto the VMAC bracket using the 3 OEM screws. The fasteners can be accessed through the holes in the pulley (Figure 18).

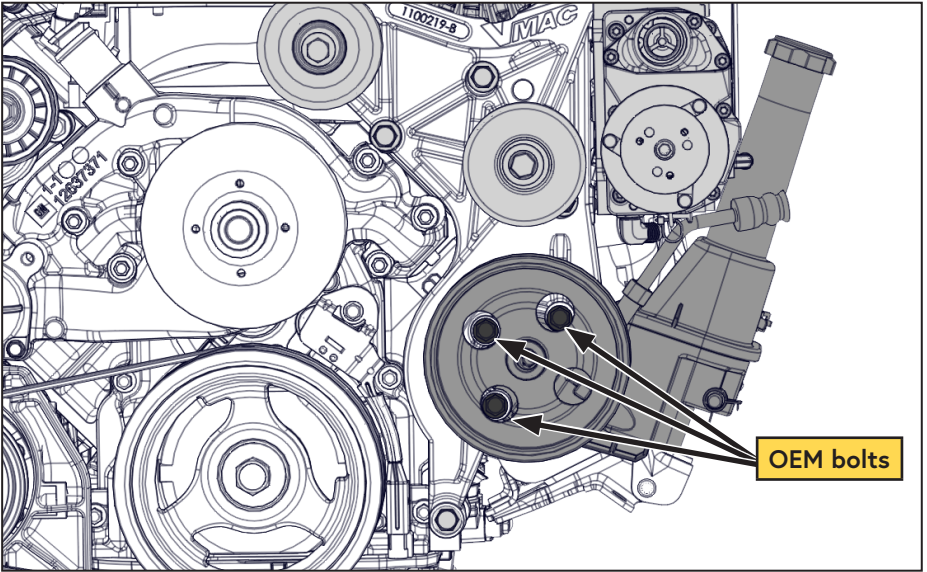

Figure 18 — Power steering pump installation

- Install the VMAC supplied FEAD belt, ensuring the belt is properly seated on all of the pulleys (Figure 19).

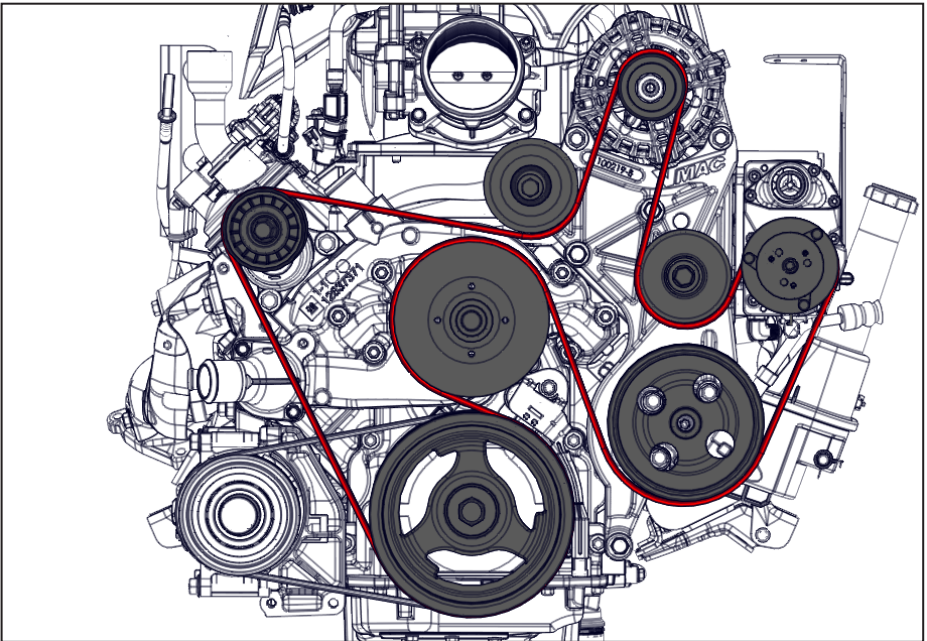

Figure 19 — FEAD belt routing

- Ensure the belt spans the middle 6 ribs of the compressor pulley leaving 1 rib visible on each side of belt (Figure 20).

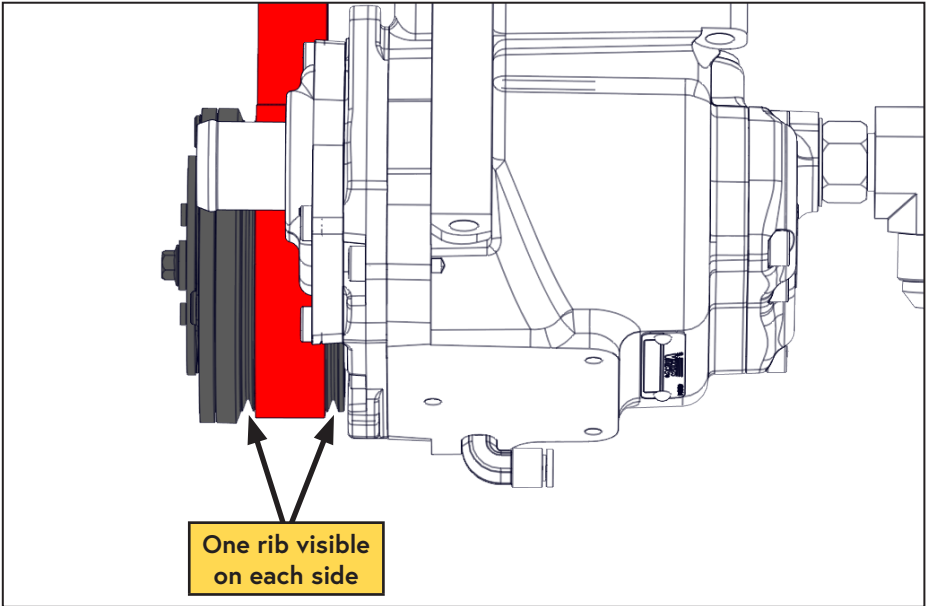

Figure 20 — Compressor belt alignment

- Install the VMAC compressor air filter assembly using the supplied nuts (Figure 21).

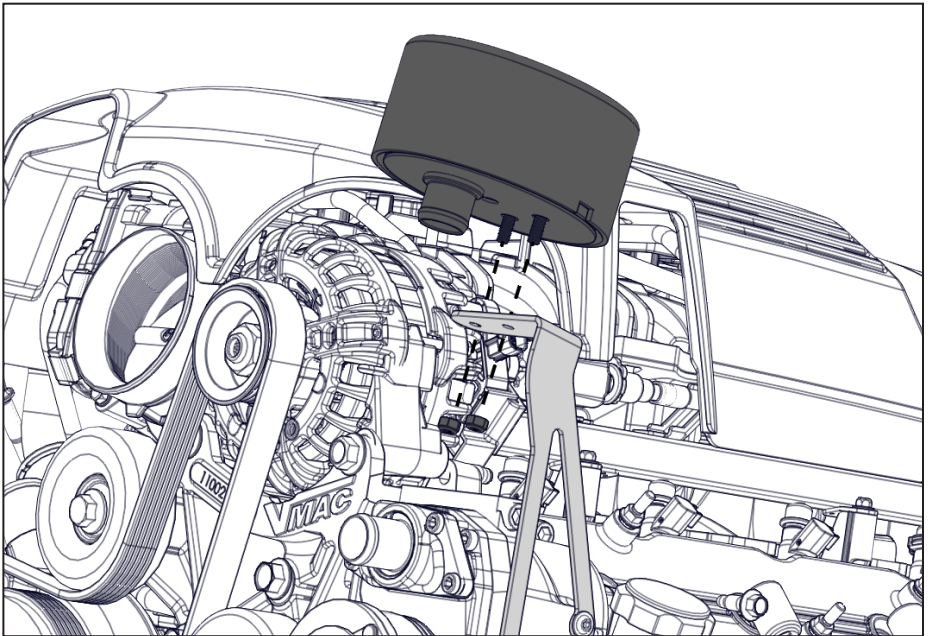

Figure 21 — Mount air filter

- Install the hose between the air filter assembly and the compressor and secure with the supplied gear clamps (Figure 22).

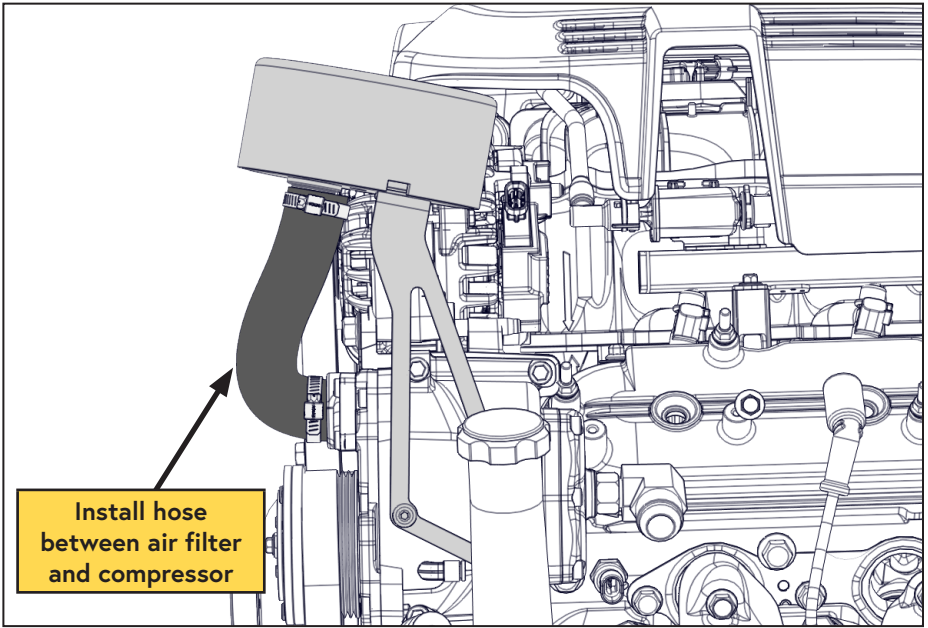

Figure 22 — Install air filter hose

- Reinstall the upper radiator fan shroud, ensuring the rubber radiator bushings are in place (3 bolts on each side and 2 on the front).
- Secure the radiator hose and wire loom to the fan shroud using the OEM clips.
- Secure the top power steering hose to the lower hose with the supplied cable tie to ensure the hose is kept away from the belt.

Installing the Waste Heat Air Separator Package (WHASP) Tank

WHASP Tank location guidelines



When determining a mounting location for the WHASP Tank, ensure the following conditions are met:

- Adequate supply of fresh air and venting for the cooling fan.
- Minimum of 12 in of clearance at the front of the unit.
- Minimum of 6 in clearance at the rear of the unit.
- Hose connections and wiring are accessible.
- Mounted on a level surface.
- Impact protection.
- The oil level sight glass is easily accessible.
- The oil fill and drain ports are accessible for servicing.
- Minimize the hose lengths to maximize performance.

Mounting the WHASP Tank

Refer to (Figure 23) for mounting dimensions.

Special consideration must be made to ensure the WHASP Tank will be protected from damage and to ensure that it has adequate ventilation.

In some cases, it may be necessary to fabricate a mounting bracket to position the tank in an appropriate location.

Secure the WHASP Tank by bolting the mounting feet to the installation surface, use M8 or 5/16 in fasteners (not supplied).

Mounting in an Enclosure or Body

Mounting the WHASP Tank in an enclosure will limit access to cooling air or restrict the escape of hot air from around the unit and will have an adverse effect on cooling.

Ensure adequate ventilation is provided for the cooling system to function properly.

It is not possible to make absolute recommendations regarding ventilation because of the widely differing configurations that are possible. Duty cycle, ambient temperature and enclosure shape are some of the important variables that need to be taken into account when determining the suitability of enclosure mounting.

Cool air ducted to the cooler and installing an exhaust fan to remove hot air is recommended.



Confirm the hose lengths included in this kit when determining the location of the WHASP Tank and bulkhead fittings. Hose lengths can be found in the Illustrated Parts List (IPL). If the WHASP Tank or bulkhead fitting location requires longer hoses, contact a local VMAC dealer. See page 6 for ordering information .

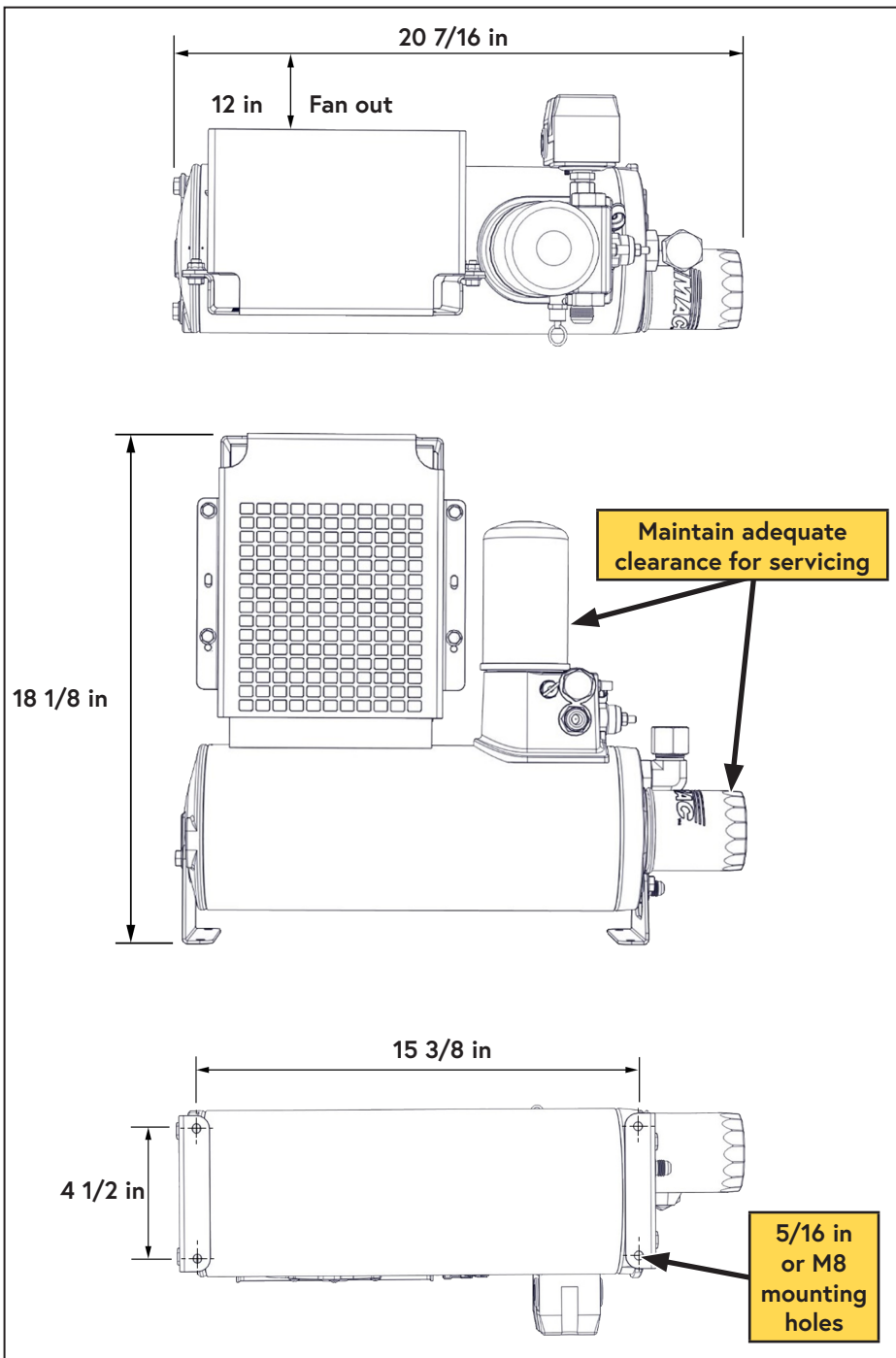

Figure 23 — Minimum WHASP Tank mounting clearances

Mounting the WHASP Tank

The WHASP Tank uses a "puller" fan to cool the air/oil mixture. Position the WHASP Tank to ensure there is adequate air flow and so that the fan is blowing out toward the cargo door. During operation, the door should be kept open to ensure there is a constant supply of cool air to prevent the system from overheating (Figure 24).



Provide ample space to check the oil level, as well as access to the filters and compressor oil drain to facilitate servicing.

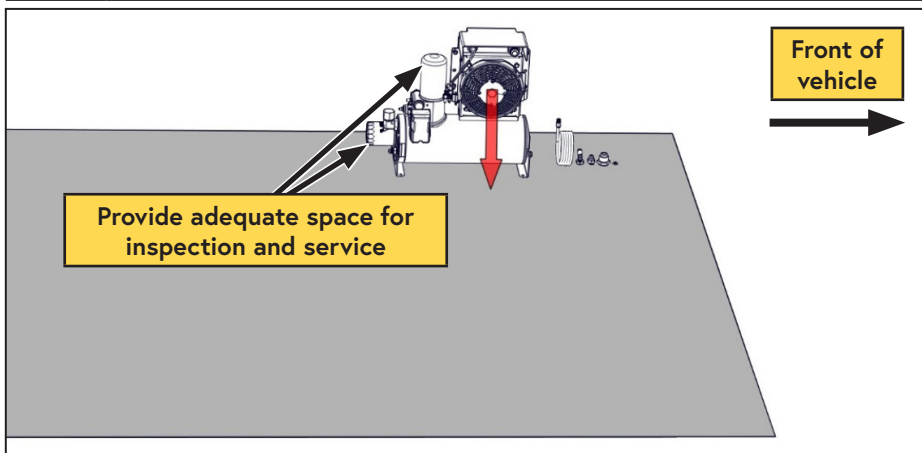

Figure 24 — WHASP ventilation



A minimum of 6 in of clearance is recommended around the radiator (intake) side of the WHASP Tank to allow fresh, cool air to circulate into the cooler and fan (Figure 25).

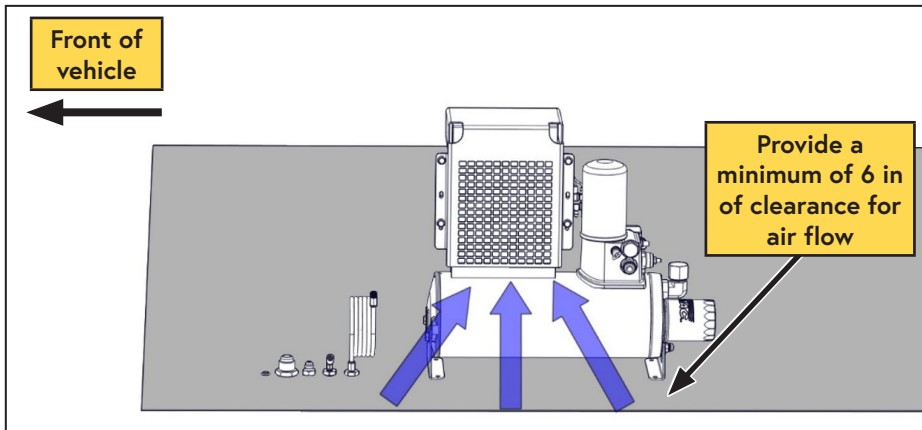

Figure 25 — WHASP ventilation

Hose Requirements



*Only attempt to shorten the supplied hose if there is access to the appropriate equipment. **Do not** cut and splice the hose using hose clamps.*



VMAC Compressor oil will degrade rubber lined hoses, use only hoses with an AQP elastomer type liner. Contact VMAC Technical Support at 1-888-241-2289 for further information.

The 1/4 in PTFE tube, and the 3/8 in and 3/4 in hoses with AQP elastomer liner, are specifically designed to work with VMAC compressor oil and at compressor operating temperatures.

Based on the desired location of the WHASP Tank, the hose lengths provided with this system may not be ideal. They can be shortened or replaced as necessary, or hose extenders can be used.

VMAC recommends shortening these hoses as a preferred alternative to coiling up and securing the excess.



Shorter hose lengths will maximize system performance.



Avoid using 90° fittings wherever possible as they cause flow restrictions and negatively impact performance.

The following hoses are included with this compressor kit:

From the compressor to the WHASP Tank:

- 3/4 in × 170 in.
- 3/8 in × 170 in.
- 1/4 in (PTFE Tube) × 180 in.

If longer hoses are required:

To order parts, contact a VMAC dealer. The dealer will ask for the VMAC serial number, part number, description and quantity. See page 6 for ordering information.

- Eaton Aeroquip hoses with an "AQP" type inner liner are required.
- OTC fittings are required for the VMAC supplied hose.
- Push-lock fittings are suitable if FC332 hose is used.
- If Push-lock fittings are being used, do not use hose clamps as they will damage the hose and cause leaks.

Connecting the Hoses



When routing hoses, ensure cap plugs are installed so that contaminants do not get in the line. Take care when routing hoses, as a hose failure may damage the compressor and/or cause injury.



All hoses, tubes and wires that are installed, rerouted or shifted during the installation must be secured so that they do not contact any hot, sharp or moving parts. Use rubber coated P-clips wherever possible. Follow the routing suggestions in this manual and cover all hoses with plastic loom.



Ensure there is sufficient slack in the hose routing to allow for normal engine movement.

PTFE Tubing, Loom, and Push-To-Connect Fittings

- PTFE tubing should only be cut using proper tubing cutters. Side cutters, utility knives, etc. will deform the tube, preventing a proper seal (or leave sharp edges which cut the internal O-ring).
- When applying loom to the PTFE tube, leave approximately 1 in between the loom and the fitting.
- Ensure the tube is clean, cut at 90° and that there are not sharp edges.
- Lubricate the tube and firmly push it into the fitting so that the tube fully seats in the fitting.
- Slide the collet out, away from the body of the fitting to lock the tubing in place.
- Ensure the tube does not have any "play" to prevent the O-ring from wearing.

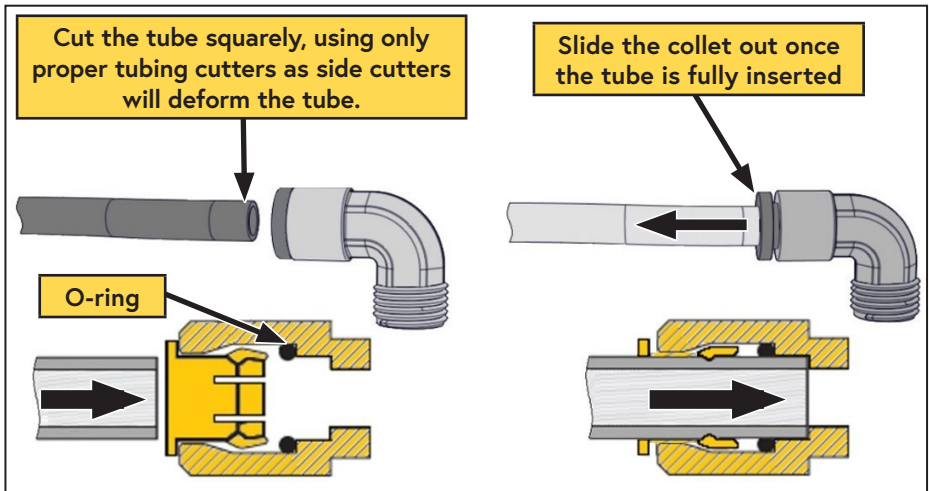

Figure 26 — Push-to-connect fittings

- Apply loom (not supplied) to the 3/4 in and 3/8 in hoses, as well as the 1/4 in PTFE tube.
- Connect the straight end of the 3/4 in hose to the matching fitting on the rear of the VMAC compressor.
- Connect the 1/4 in PTFE tube to the 90° push-to-connect fitting on the compressor. Ensure the tube fully seats in the fitting.
- Determine a suitable routing path for the hoses running from the compressor to the WHASP tank; avoid hot, sharp or moving components.



Ensure there is sufficient slack in the hose routing to allow for normal engine movement.

- Bundle the 1/4 in PTFE tube, the 3/4 in, and the 3/8 in hoses and route them to the WHASP Tank.
- Connect the 90° fitting on the 3/4 in hose to the #12 JIC fitting (air/oil inlet) on the cooler above the fan (Figure 27).
- Connect the 90° fitting on the 3/8 in hose to the #6 JIC fitting (oil return fitting) beneath the oil filter on the tank (Figure 27).
- Connect the 1/4 in PTFE tube to the 1/4 in push-to-connect (oil scavenge) fitting near the coalescing filter (Figure 27).
- Connect the discharge fitting (#8 male JIC) to the customer's air system (hose not supplied).
- Secure all hoses, tubes, and wires with P-clips and/or cable ties.

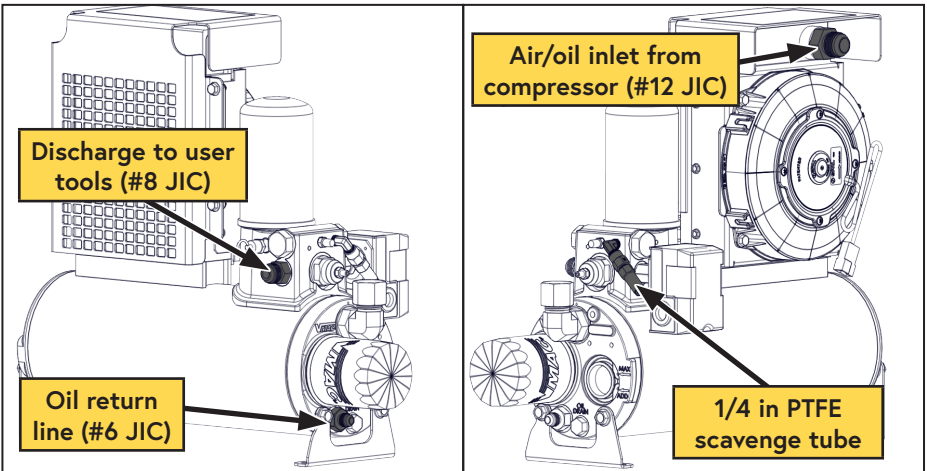

Figure 27 — WHASP Tank connections



Use of an air receiver tank (minimum 6 USG) is required with this application. Follow the instructions on page 42 of this manual to prevent damage to the system.

Adding Oil to the System



The VMAC supplied and approved compressor oil must be used in this system. Failure to use this special oil will result in damage to the compressor and will void warranty.

Do not overfill the system. Overfilling the system with oil can flood the sight glass window and make the system appear empty.

- Remove the fill cap on the WHASP Tank (above the sight glass) (Figure 28).
- Using a funnel, pour oil into the tank until the oil level in the sight glass reaches the "MAX" line. **The system capacity is 4 L** (Figure 28).
- Reinstall the fill cap and tighten it securely. Ensure the fill port remains accessible as it will be necessary to check and top up the oil after the first compressor start.

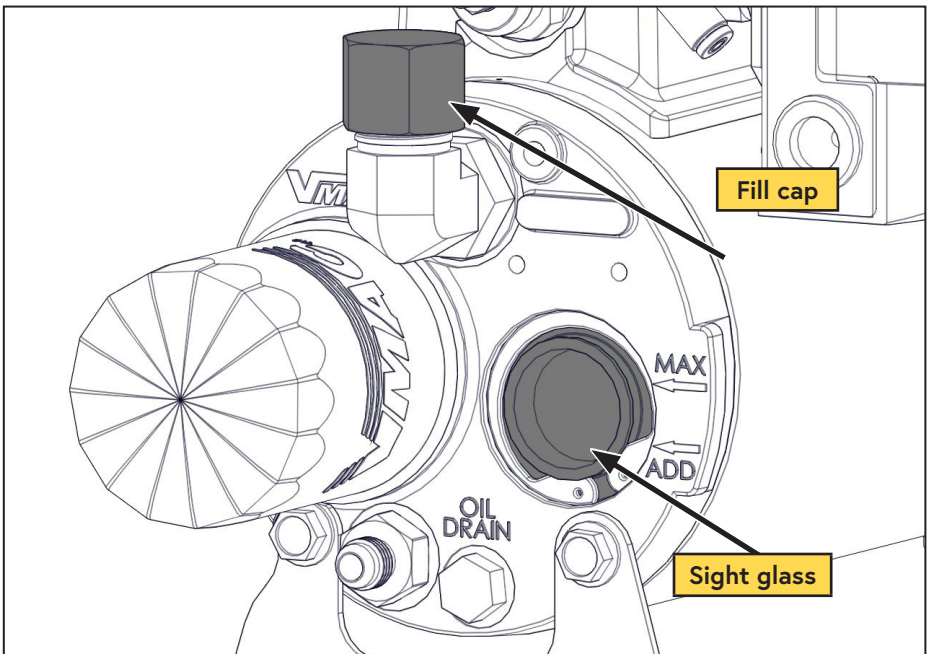

Figure 28 — Filling the WHASP Tank

Installing the Control System

Best Practices

- To confirm a good ground, use an ohm meter to measure the resistance between the ground point and the negative battery terminal. Resistance should be less than $1\ \Omega$.
- Route all wires to ensure they will not contact hot, sharp or moving parts (including the park brake mechanism, steering column, and pedals).
- Before drilling any holes ensure there are no OEM wires, hoses, or components that may be damaged.
- Do not use a test light to probe for power on vehicle circuits, the increased current draw of the test light may damage components.
- Whenever possible, solder all electrical connections and protect the joint with heat shrink.
- Apply loom to all wiring:
 - Use high temperature loom in areas where high temperatures may be expected.
 - Use spiral loom in areas with high vibration.

Splicing into OEM Wiring (Figure 29 and Figure 30)

VMAC recommends against cutting OEM wires whenever practical. The preferred method is to remove the pin from the connector using an appropriate tool and slide the shrink tube onto the wire. Strip the wire at the desired location and solder the VMAC wire into place. Slide the shrink tube up to the soldered joint and seal it. Finally, replace the pin in the connector, taking special care to ensure the pin is fully inserted and the locking tabs are engaged.

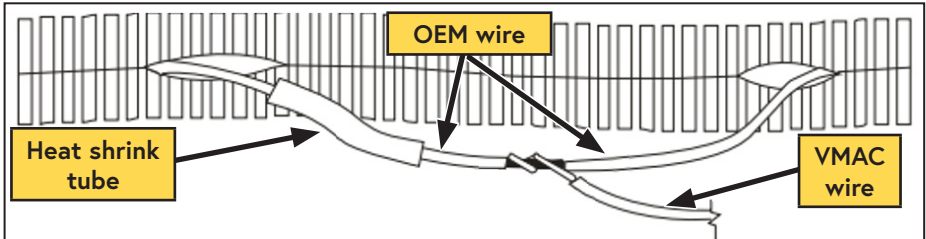

Figure 29 — Solder spliced joint

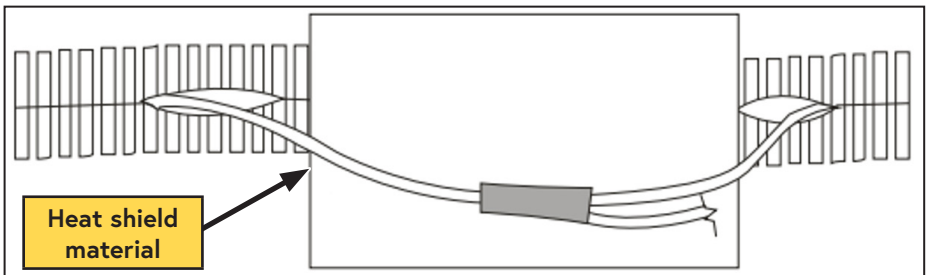

Figure 30 — Seal soldered joint

Electrical Modules

- The Throttle Control, Control Module, and Interface Panel are not weather proof; ensure they are mounted where they will be protected from rain, snow, mud, direct sunlight, etc. (e.g. inside the cab, service body or cabinet).
- Keep the rear of the Interface Panel protected.
- Ensure the Control Module and Throttle Control are mounted away from the pedals, park brake mechanism, or where they could be inadvertently knocked by occupants.

Control Components Overview

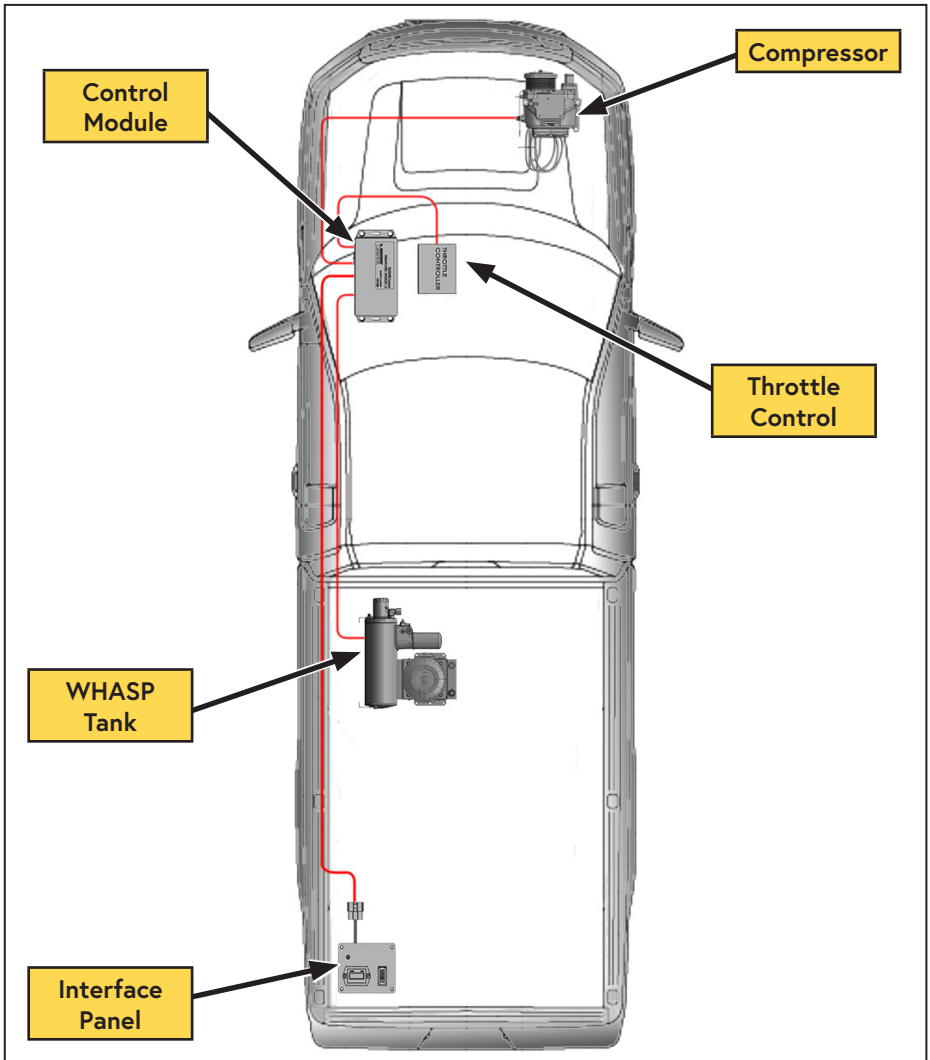

Figure 31 — General component overview
(Actual installation locations may vary)

Control Module (Figure 32)

The Control Module serves as the primary input/output interface between the vehicle and the various VMAC components (compressor, Throttle Control, WHASP Tank, Control Interface, etc.).

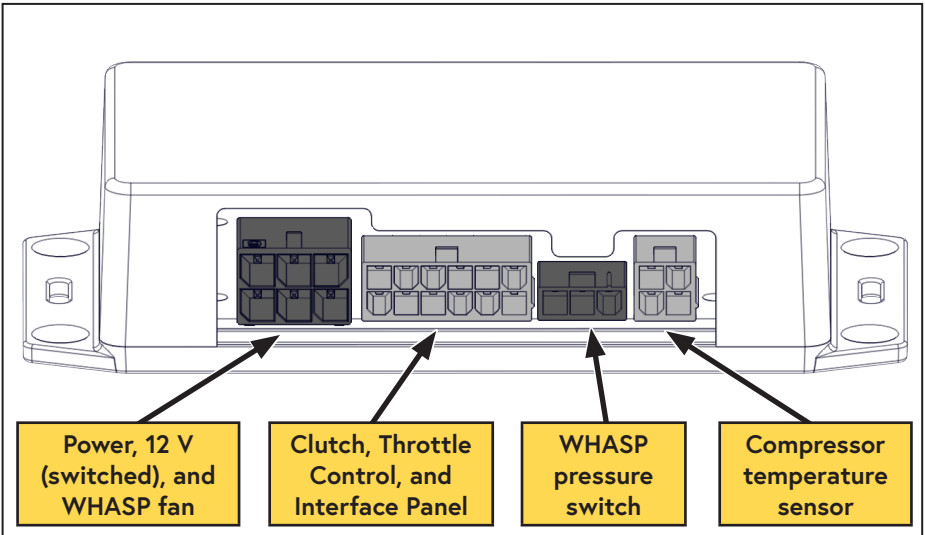

Figure 32 — Control Module

Interface Panel (Figure 33)

The Interface Panel serves as the operator's control panel and contains the "ON/OFF" switch, compressor status light, and the compressor hour meter.

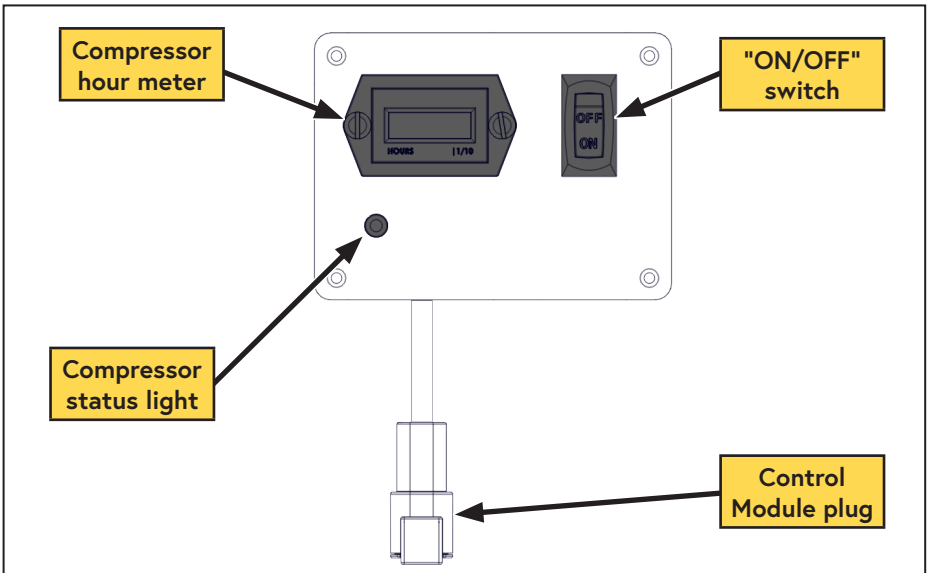

Figure 33 — Interface Panel

Throttle Control (Figure 34)

The Throttle Control responds to signals from the pressure sensor and commands the vehicle's throttle to increase or decrease engine speed in response to air demand.

The Throttle Control also allows the operator to configure the vehicle's engine speed (when air is demanded) to their needs (maximum cfm, specific tool requirements, fuel efficiency, or a combination of these factors).

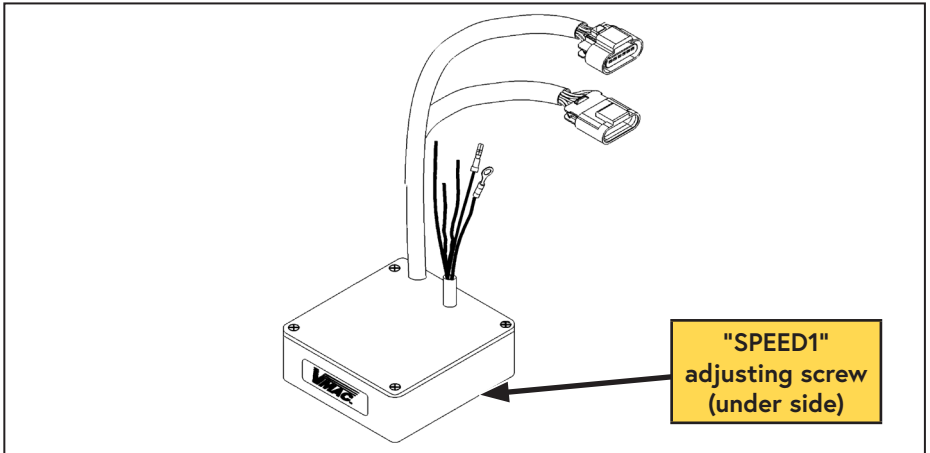

Figure 34 — VMAC Throttle Controls

Mechanical Pressure Switch (Figure 35)

The mechanical pressure switch is mounted on the side of the WHASP Tank and limits the maximum pressure to a safe amount by disengaging the clutch once system pressure is achieved.

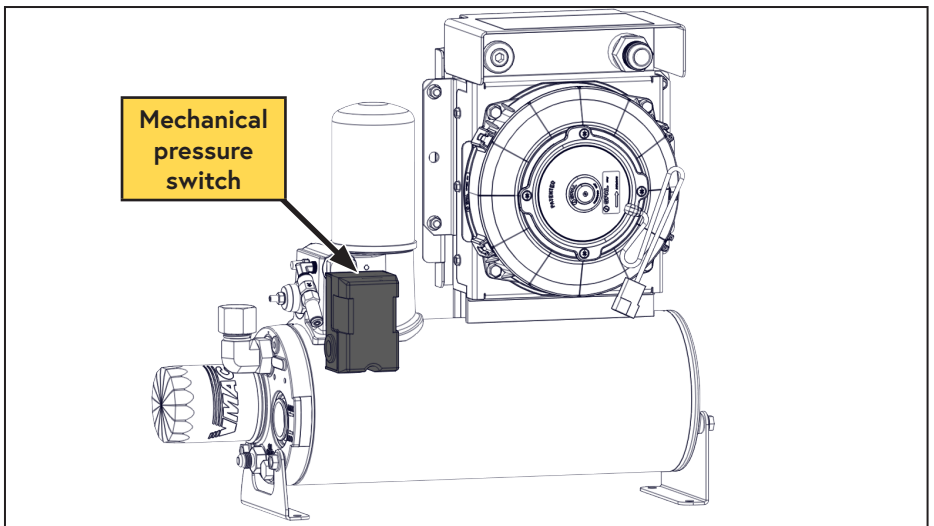

Figure 35 — WHASP Tank pressure switch

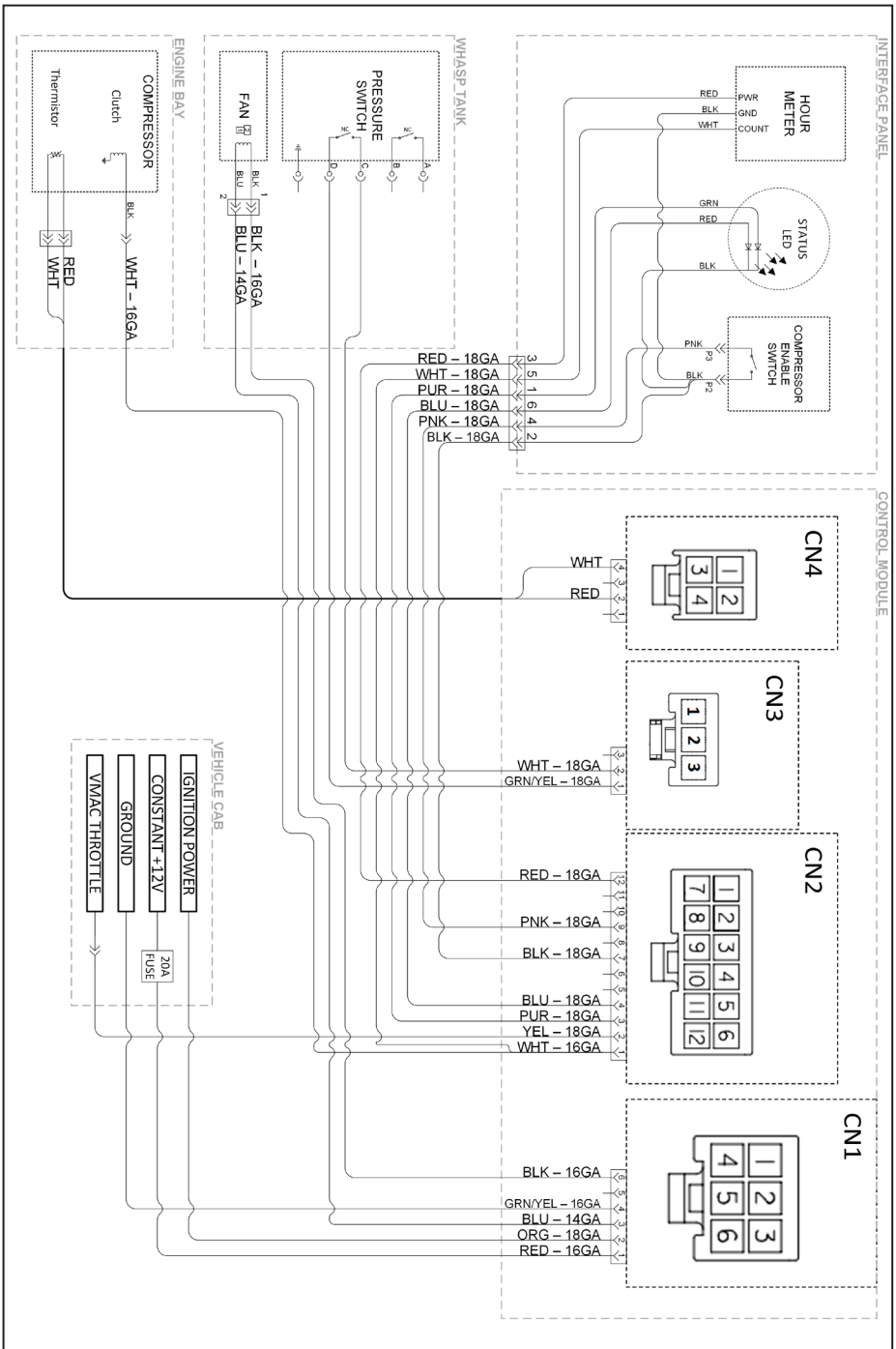

Figure 36 — Electrical schematic

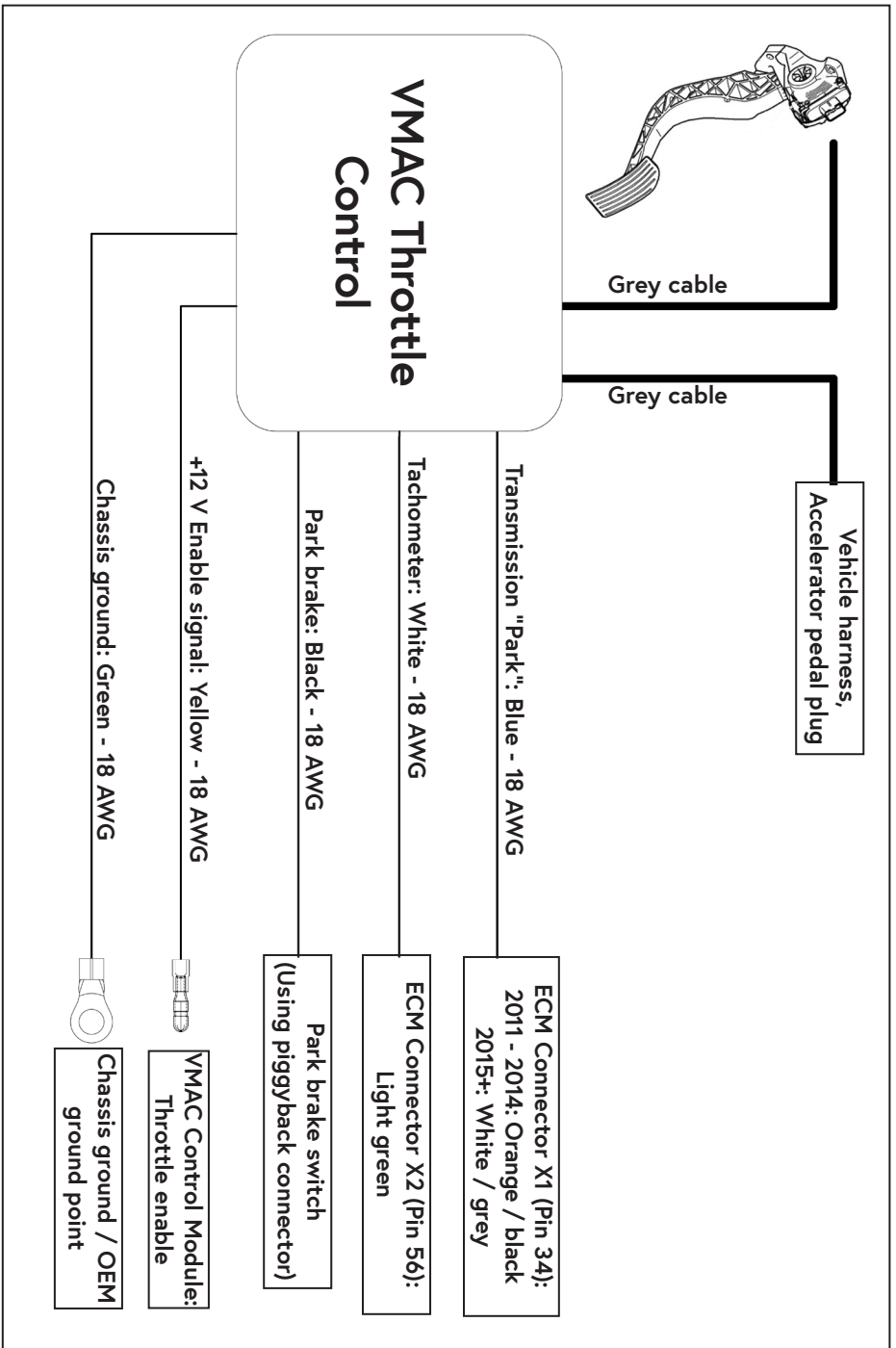

Figure 37 — Wire schematic

Installing the Control Components

Throttle Control

- Mount the Throttle Control under the dashboard away from the pedals, steering column, and the park brake mechanism and positioned so that the "SPEED1" adjusting screw is accessible.
- Unplug the cable from the foot pedal assembly and connect it to the throttle control.
- Connect the green ground wire from the Throttle Control to a chassis ground.
- Route the black wire over to the park brake.
- Unplug the connector from the park brake switch and connect the black wire with the piggyback connector from the interface cable to the connector on the park brake switch.
- Connect the OEM park brake connector to the piggyback connector.

Control Module

- Plug the 4 harnesses into the Control Module.
- Mount the Control Module under the dashboard, up and out of the way of the pedals, steering column, and the park brake mechanism.
- Connect the green ground wire from the Control Module to a chassis ground.
- Locate a grommet in the firewall and pass the following wires from the Throttle Control and Control Module through to the engine bay*:
 - *White 16 AWG wire from the Control Module (clutch wire).
 - *Red wire from Control Module (constant power).
 - *White wire from the Throttle Control (tachometer signal wire).
 - *Blue wire from Throttle Control (PARK signal wire).
 - *Grey cable with the green connector from the Control Module (temperature sensor).
- Connect the bullet connector on the white wire running from the Control Module to the bullet connector on the black wire running from the compressor.
- Connect the green connector on the grey cable to the matching connector on the compressor.
- Splice the white wire from the throttle controller to the green wire at pin 56 of the ECM X2 connector.
- Splice the blue wire from the VMAC throttle controller to the wire at pin 34 of the ECM X1 connector.
 - 2011 - 2014:** Orange wire with black stripe.
 - 2015+:** White wire with grey stripe.
- Put the wires back into the OEM loom and wrap with electrical tape. Use 1/4 in wire loom to protect the wire and secure it with a cable tie.
- Crimp the supplied fuse holder to the red wire running from the Control Module. Ensure the fuse holder is installed as close to the power source as possible.
- Connect the other end of the fuse holder to the positive battery terminal.

Connecting Switched Power 2011 - 2014

- Remove the key switched fuse located earlier in the installation.



Ensure the fuse tap is inserted with the correct tap orientation (determined earlier in the installation process).

- Install the VMAC fuse tap. Ensure the populated fuse in the fuse tap for the VMAC system is obtaining power from the supply/hot fuse connection. Plug the vehicle fuse back into the empty (lower) fuse tap socket and ensure the supplied 10 A fuse is in the upper socket. Ensure the fuse is seated properly (Figure 38).

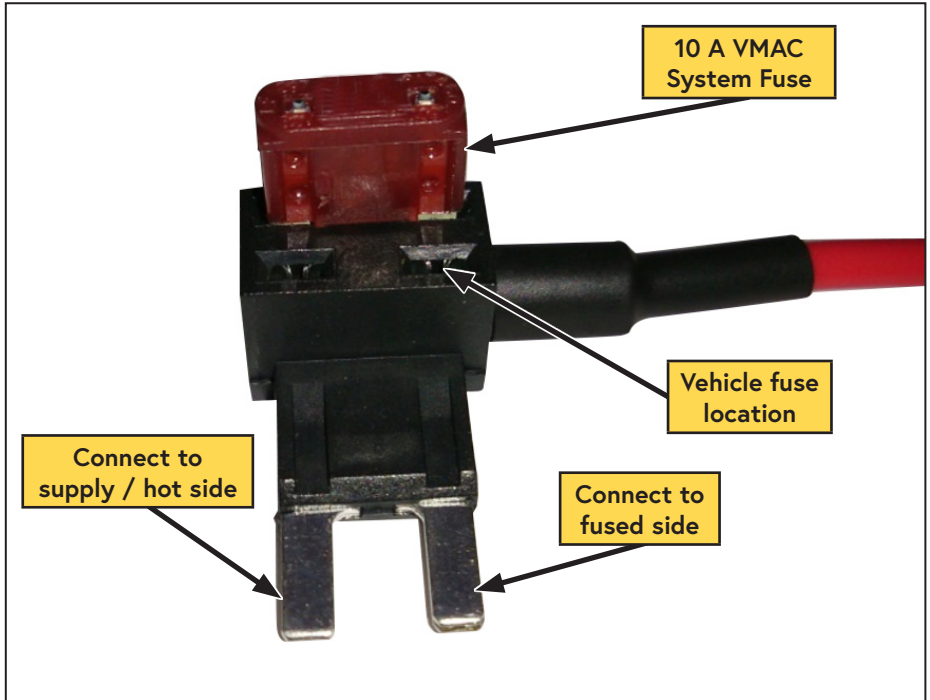

Figure 38 — VMAC fuse tap (for 2012 – 2013 vehicles only)

- Crimp the wire from the VMAC fuse tap to the orange wire from the Control Module.

Connecting Switched Power 2014+



The supplied tap fuse cannot be used on 2014+ vehicles. The VMAC system can be wired using the directions below or as per GM bulletin UI #115C (scan or click the QR code below).



- Locate the ICEM (formally referred to as the MidBEC or MBEC) which is located in the driver side foot well, near or below the parking brake mechanism (Figure 39).



Figure 39 — ICEM location

- Remove the plastic cover on the ICEM by gently prying the 3 locking tabs away from the housing to release the cover.
- Remove the 3 nuts securing the module (Figure 40).

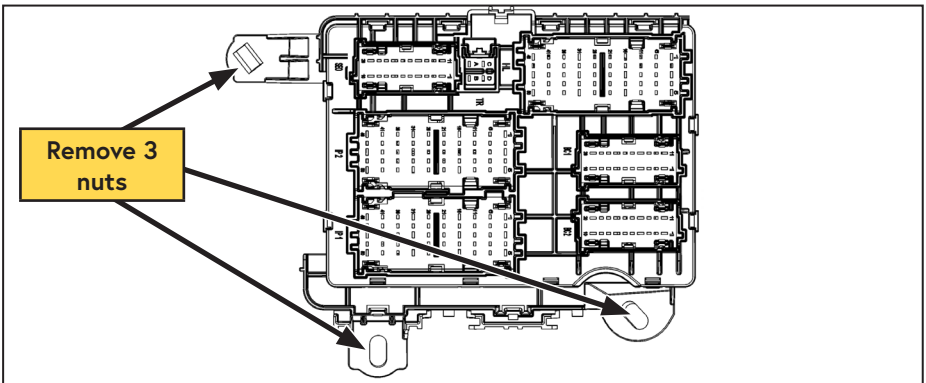

Figure 40 — Accessing the rear of the ICEM

- Lift the assembly up and out of the way to give clearance to the electrical connectors on the back of the module.
- There are 2 electrical connectors on the rear of the ICEM assembly. Squeeze the 2 tabs and rotate the locking lever on the passenger side connector to remove it from the ICEM module (Figure 41).

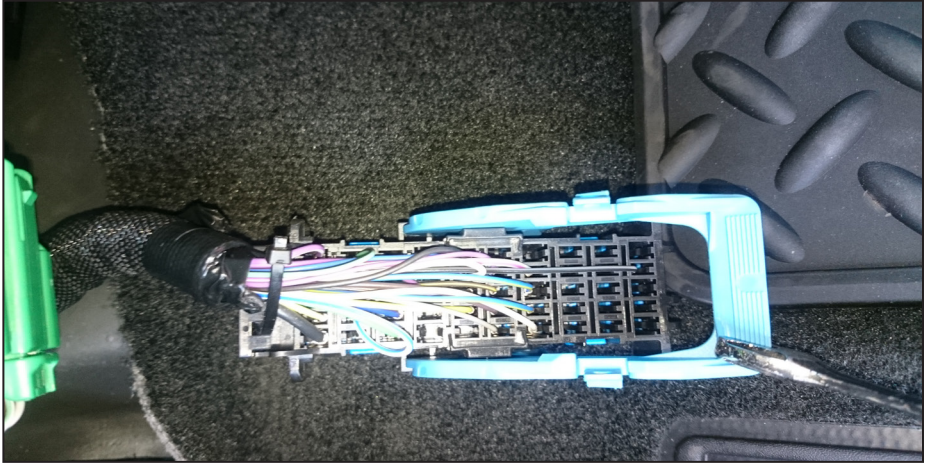

Figure 41 — ICEM connector

- Locate the violet wire with white stripe running to pin 46 of the ICEM connector (Figure 42).

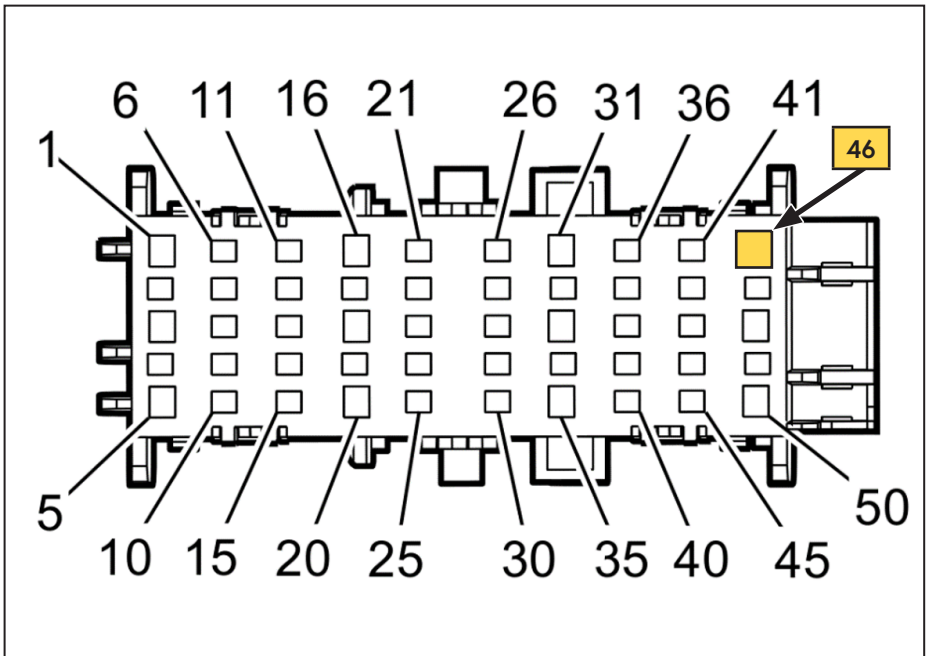

Figure 42 — Locating ignition switched power

- Splice the orange wire from the VMAC interface connector to the violet wire with white stripe.
- Cover the soldered wire with 1/4 in loom, insert the wires back into the OEM loom and secure with a cable tie.
- Reinsert the ICEM connector into the ICEM module.
- Reinstall the ICEM module.

Securing the Wiring

- Ensure all wires are adequately protected with loom (or equivalent protection) and routed away from any hot, sharp or moving components.
- Pull all excess wires and harnesses into the cab of the truck.
- Neatly bundle all the wiring in the cab and secure the bundles with cable ties to keep them away from the park brake mechanism, the steering column, and the accelerator and service brake pedals.

Interface Panel

- Install the Interface Panel in a suitable location (Figure 43).

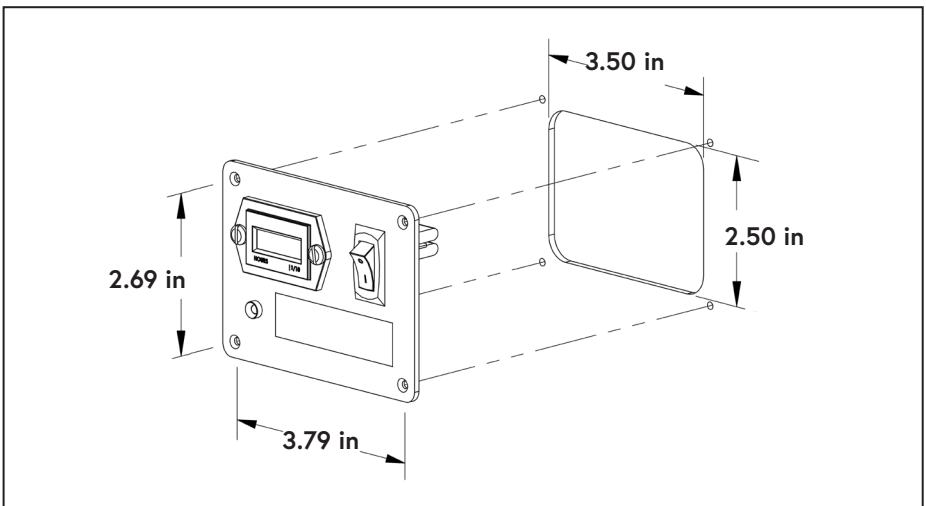

Figure 43 — Interface Panel mounting dimensions

- Connect the harness from the Control Module to the Interface Panel.
- Connect the fan connector from the Control Module to the plug on the WHASP Tank.

- Remove the cover from the WHASP Tank pressure switch and connect the 2 ring terminals from the control module to the pressure switch on the WHASP Tank (not polarity dependent) (Figure 44).

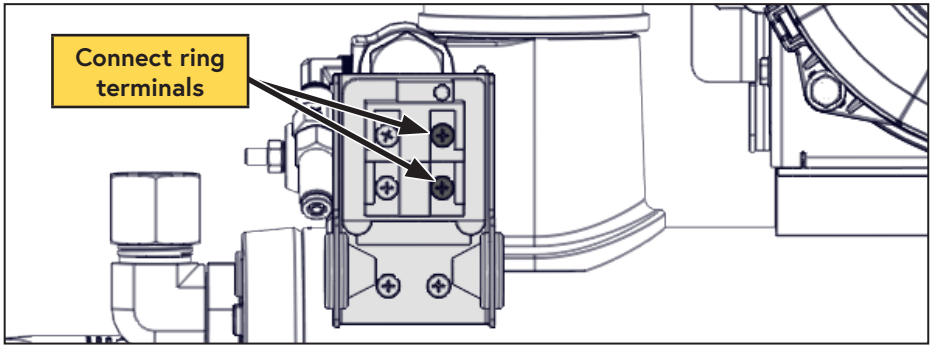

Figure 44 — Connect pressure switch

- Replace the cover when finished.



The WHASP Tank harnesses are made to a generic length. Any excess harness should be coiled up and secured out of the way. There are 2 extra ring terminals included with the pressure switch harness; if desired, cut the harness to length and crimp the spare ring connectors to it.

- Ensure all wires and harnesses are protected with loom and routed away from sharp, hot, or moving components and away from high traffic areas.

Air Receiver Tank



Pressure in the air receiver tank will not be relieved when the compressor system blows down. This is normal operation. Prior to performing any service work on the system, discharge any stored air in the air receiver tank.



The VMAC WHASP Tank has a built-in check valve. Use of an additional check valve is not required and may cause erratic performance.

The VMAC compressor system will automatically depressurize when it is shutdown. The WHASP Tank has a built in check valve which prevents blow back and moisture from the receiver tank entering the WHASP Tank. Installation of an additional check valve will cause erratic performance.

While the air receiver tank can be installed at any height in relation to the WHASP, the discharge hose running from the WHASP must be installed as high as possible on the air receiver tank to prevent problems with condensation that may have accumulated in the receiver tank (Figure 45).

Drain the condensed water from the receiver tank daily.

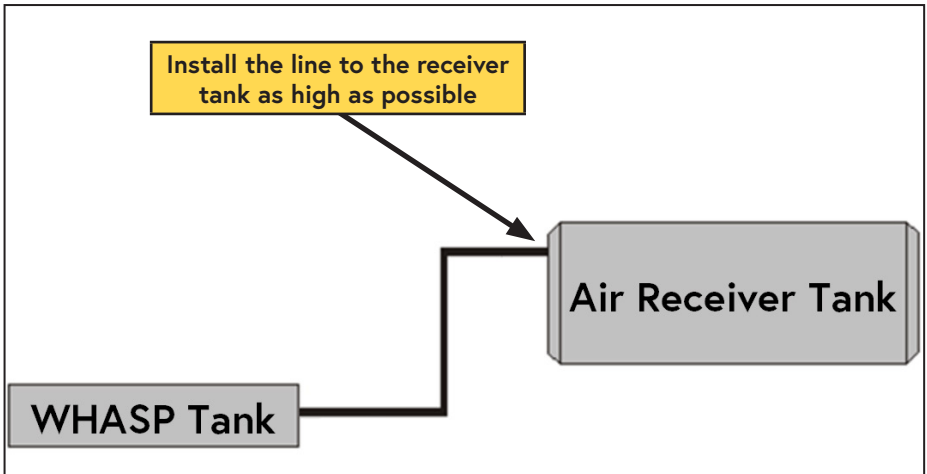

Figure 45 — Air receiver tank

Recommended Accessories

While the compressor system will function without the following accessories, VMAC strongly recommends their use for optimal performance.

See the "Accessory Product" section of this manual on page 50 for a list of products available for purchase through VMAC.

Larger Air Receiver Tank

A larger capacity air receiver tank provides a larger buffer as it gives the compressor time to react by increasing the engine speed and producing air before the tool stalls. It also has the advantage of lowering the duty cycle of the compressor system.

(This application requires a minimum air receiver tank size of 6 USG).

Pressure Gauge

While not critical to system performance, a pressure gauge is important for fine tuning the system and simplifies any potential troubleshooting.

Install a 200 psi pressure gauge downstream of the air discharge valve.

Pressure Regulator and/or Lubricator or FRL

The compressor can produce air pressures up to approximately 150 psi (1035 kPa). It is the responsibility of the user to know the pressure and air flow requirements of the tools powered by the air compressor system.

An appropriate air pressure regulator and lubricator can be installed downstream of the air discharge valve. Failure to regulate the air pressure may cause damage to the tool.

Completing the Installation

- Check all VMAC and OEM wiring to ensure that it will not contact any hot, sharp or moving components and will not interfere with the operation of the vehicle. Secure all wiring with rubber coated P-clips, cable ties and loom as required.
- Check all VMAC and OEM hoses and tubes to ensure that they will not contact any hot, sharp or moving components and will not interfere with the operation of the vehicle. Secure all hoses and tubes with rubber coated P-clips, cable ties and loom as required.
- Replace the fuse panel cover.
- Replace the dashboard panel.
- Reconnect the battery.

Testing the Installation



Lift the vehicle, ensuring the driven wheels are off of the ground. Support the vehicle securely with appropriately rated jack stands. Ensure there are no people around the vehicle before beginning the test.

If the vehicle fails the test, ensure the wiring to all of the connections are correct and secure. If additional assistance is required, contact your local VMAC dealer or call VMAC Technical Support 1-888-241-2289 or 250-740-3200.

Safety Test

Ensure the following has been completed:

- Place the transmission in "PARK" and apply the park brake. Turn the ignition key to "ON" but do not start the engine.
- Turn on the compressor and listen for the compressor clutch to engage.
- Observe the hour meter, and ensure the hourglass icon is blinking.
- Turn off the compressor switch and ensure the clutch has disengaged.

Before Starting the Engine Checklist

Ensure the following has been completed:

- Check that the compressor oil level at the tank sight glass is correct.
- Complete a final inspection of the installation to ensure everything has been completed.
- Perform a final belt alignment check.
- Check all wiring for security and protection. Ensure nothing is touching the compressor body.
- Ensure all of the compressor outlets are closed.
- Ensure the parking brake is engaged and the transmission is in "PARK".
- Start the engine.

After Starting the Engine Checklist

- Allow the vehicle to reach operating temperature.
- Turn on the compressor. The compressor clutch should engage, and the engine speed should increase in response to the throttle control. The vehicle's tachometer should indicate approximately 2,000 rpm.
- Allow the compressor to run for approximately 10 seconds.
- Turn off the compressor.
- Shut down the engine.
- Check the compressor oil level after the engine has been shut down and the oil level has had time to stabilize.



Ensure any stored air is drained from the system prior to adding oil.

- Add oil as necessary to bring the level to the "FULL" line in the sight glass and check for leaks.
- Start the engine. Assistance may be required for the next steps.



The following tests confirm that the drive disable system is working correctly. The drive disable system prevents the VMAC throttle from increasing engine rpm unless the transmission is in "PARK" and the park brake is engaged.

2 people are required to perform this safety test. 1 person must remain in the driver seat and be prepared to actuate the service (foot) brake if necessary.

The second person will actuate the compressor switch and ball valve as necessary

- Install the VMAC Air Test Tool (P/N: A700052) with the 40 cfm (5/32 in) orifice installed and the ball valve closed.
- With the engine running and the vehicle in "PARK", release the parking brake.
- Turn on the compressor and open the ball valve. The clutch should engage, but engine speed should NOT increase.
- Close the ball valve.
- Turn off the compressor.
- Reapply the park brake.



The steps marked with asterisks will be repeated.

- *With the engine running, Depress the service (foot) brake and shift the transmission out of "PARK".
- *Turn on the compressor and open the ball valve. The clutch should engage, but engine speed should NOT increase.
- *Close the ball valve.
- *Turn off the compressor.
- *Drain any accumulated air from the system.
- *Shift the transmission into "PARK".
- Repeat the steps marked with asterisks for all transmission selector positions, returning the gear selector to "PARK" after each gear is tested.



Engine speed should not increase unless the vehicle is in "PARK" or "NEUTRAL".

- Drain any air that may have accumulated during the previous tests.
- Ensure the parking brake is engaged.
- Turn on the compressor and open the ball valve.
- Release the park brake. The engine speed should drop to base idle.
- Reapply the park brake. The engine speed should increase as soon as the park brake is engaged.
- Close the ball valve, allow the system to build to full pressure and the engine speed to return to base idle.
- Turn the compressor off and shut down the engine.
- Drain any accumulated air from the system.

Final Testing

Ensure the following has been completed:

- Operate the system with an air tool (or the VMAC Air Test Tool with the appropriate orifice installed) for at least 1/2 hour (1 hour preferred).



The WHASP Tank cooling fan is thermostatically controlled, and may start or stop without warning.

- Road test the vehicle for approximately 20 km (14 miles).
- Observe the compressor while it is operating to ensure the belts rotate properly, pulleys rotate smoothly and nothing is rubbing or contacting hot parts.
- Check all components, connections and fasteners once the engine is turned off and the system has cooled.
- Check the coolant level after the engine has been operated.
- Check the compressor oil level after the engine has been shut down and the oil level has had time to stabilize.



The VMAC Throttle Control is not tuned for maximum cfm output! For instructions on throttle adjustment and compressor performance testing, see the instructions starting on the next page.

Performance Testing and System Adjustments

Adjusting the Throttle Control

Adjustment is made by turning the "SPEED 1" adjustment screw. Turn the screw counter-clockwise to decrease engine speed, or clockwise to increase engine speed.

The Throttle Control is designed to provide 40 cfm when the throttle adjustment is at its maximum, this also prevents overspeeding the compressor.

Engine speed adjustments may be made so that the amount of air delivered by the system matches the requirements of the tools or equipment that will be used.

- This system achieves 40 cfm at 2,300 rpm.
- If the system is unable to "keep up" with a specific tool, the engine speed is too low. Try increasing the engine speed gradually, until the desired performance is obtained.
- If the system is cycling on and off rapidly when using a particular tool, the engine speed is likely higher than necessary for that tool. Try turning the engine speed down and observe the performance.



When testing the system or adjusting the VMAC Throttle Control, ensure the system does not exceed 2,500 engine rpm. Exceeding this speed will cause erratic system performance and in extreme cases may also cause long term damage to the compressor.

If the system is overspeeding, verify all wiring connections and retest. If the system continues to overspeed, contact VMAC Technical Support at 888-241-2289.

Compressor Performance Testing

This system has been adjusted at the factory for general operation, not maximum cfm. Any performance testing should be done with the Throttle Control set for maximum cfm. See the previous page for instruction on adjusting the Throttle Control.

System operation can be tested using the tools that will be operated by the system or by using the VMAC Test Tool (A700052) with the 40 cfm (5/32 in) orifice in the outlet to simulate tool use (Figure 46).

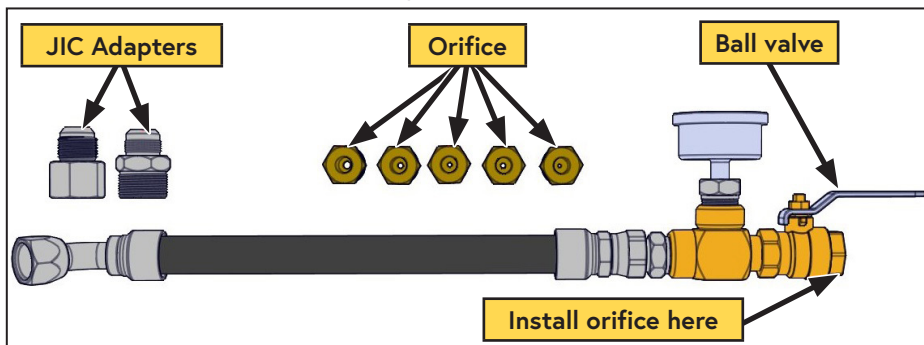

Figure 46 — A700052 VMAC Air Test Tool



Disconnect all downstream equipment (hose reels, etc.) and connect the test tool directly to the discharge fitting on the WHASP Tank.

Ensure there are no leaks in the test tool. The system may not idle down if there are leaks in the lines or fittings.

- Install the VMAC test tool at the system outlet with the 40 cfm (5/32 in) orifice.
- Ensure the ball valve is closed.
- Place the transmission in "PARK" and fully apply the park brake.
- Allow the engine to run until it is at operating temperature.
- Turn on the air compressor system and allow it to operate until the oil is warm.
- Observe the pressure gauge. Pressure should be approximately 150 psi.
- Open the ball valve on the test tool and observe the engine tachometer. Engine speed should increase to approximately 2,300 rpm. The pressure on the gauge should be 90 - 120 psi.
- Close the air valve slowly to allow the system pressure to rise. When the pressure reaches the pressure switch set-point of 150 psi, the system will disengage the compressor clutch and reduce the engine speed to base idle.
- Once the system pressure is at maximum, slowly open the ball valve on the test tool until the pressure on the gauge begins to drop. Engine speed should ramp up to approximately 2,300 rpm when the pressure drops approximately 40 psi below the pressure switch set-point.

Accessory Products from VMAC

Compressor Service Kits



200 Hour or 6 Month Service Kit -

Part number: A700263

Includes 4 L VMAC high performance compressor oil, oil filter, air filter, and next service due decal.

400 Hour or 1-Year Service Kit -

Part number: A700264

Includes 4 L VMAC high performance compressor oil, oil filter, air filter, spin-on oil separator, safety valve, muffler, and next service due decal.

Bulkhead Fittings

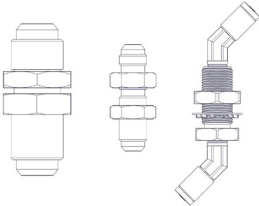

Part number: 3801095

Includes:

Bulkhead fittings are used for passing the system discharge, oil, and scavenge hoses through the floor or body panels.

- 3/4 in JIC bulkhead fitting P/N: 4900170.
- 3/8 in JIC bulkhead fitting P/N: 4900209.
- 1/8 in NPT bulkhead fitting P/N: 5000178.
- 2 x 45° 1/4 push-to-connect fittings P/N: 5000158.

Hose Fittings

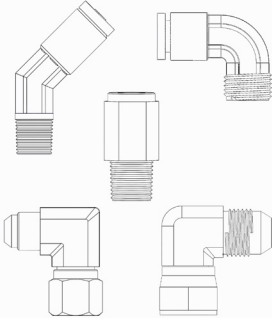

45° 1/4 push-to-connect fitting P/N: 5000158.

1/4 in push-to-connect fitting For PTFE scavenge tube.

90° 1/4 push-to-connect fitting P/N: 5000020.

1/4 in push-to-connect fitting For PTFE scavenge tube.

Straight 1/4 in push-to-connect fitting P/N: 5000012.

1/4 in push-to-connect fitting For PTFE scavenge tube.

90° 3/8 in hose fitting P/N: 4900117.

3/8 in hose fitting for Oil Return Hose.

90° 3/4 in hose fitting P/N: 4900043.

3/8 in hose fitting for Compressor Discharge Hose.

1/2 in x 50 ft Hose Reel

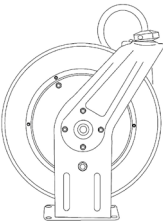

Part number: A700007

Spring-loaded 1/2 in x 50 ft hose reel; steel construction; full flow shaft and swivel for maximum performance.

6 Gallon Air Receiver Wing Tank

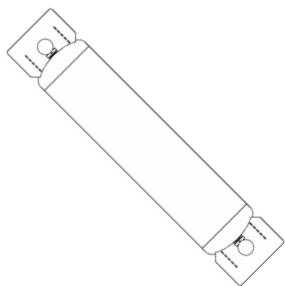

Part number: A300056

Air receiver tanks are used for lowering compressor duty cycle and removing water from compressed air; recommended for optimum operation of all VMAC Gas Driven, Diesel Driven, Hydraulic, and UNDERHOOD40 air compressors. Manufactured to FMVSS 121 standard; includes fittings, 170 psi pressure relief valve, and tank drain.

- Max pressure: up to 170 psi.
- Dimensions: 32 in (81.3 cm) L x 8 in (20.3 cm) D.
- Weight: 23 lb (10.4 kg).

10 Gallon Air Receiver Tank w/ Mounting Feet



Part number: A300047

Air receiver tanks are used for lowering compressor duty cycle and removing water from compressed air. Recommended for optimum operation of VMAC Hydraulic Air Compressors, VMAC Diesel Driven Air Compressors, UNDERHOOD40, UNDERHOOD70 – Green Series Air Compressors, and VMAC Multifunction Power Systems, which include standby mode; ASME certified; includes fittings, 200 psi pressure relief valve, tank drain, and 200 psi pressure gauge.

- Max pressure: up to 200 psi.
- Dimensions: 30 in (76.2 cm) L x 10 in (25.4 cm) D.
- Weight: 33 lb (15 kg).

35 Gallon Air Receiver Wing Tank

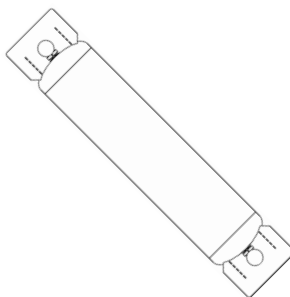

Part number: A300010

Air receiver tanks are used for lowering compressor duty cycle and removing water from compressed air. Recommended for optimum operation of VMAC Diesel Air Compressors, Hydraulic Air Compressors, UNDERHOOD40, UNDERHOOD70 – Green Series Air Compressors, and VMAC Multifunction Power Systems, which include standby mode; ASME certified; includes fittings, 200 psi pressure relief valve, tank drain, and 200 psi pressure gauge.

- Max pressure: up to 200 psi.
- Dimensions: 73 3/4 in (187.3 cm) L x 14 in (35.6 cm) D.
- Weight: 95 lb (43.1 kg).

UNDERHOOD 70 Air Aftercooler

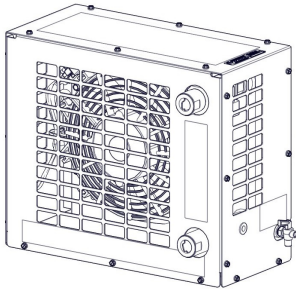

Part number: A800070

Improves tool performance and extends the life of air tools; removes up to 80% of water from compressed air; includes automatic water drain.

- Max air flow: 70 cfm / 175 psi.
- Port size: 3/4 in NPT inlet and outlet.
- Electrical: 12 V.
- Dimensions: 17 in (43.2 cm) L x 8.0 in (20.3 cm) W x 14.5 in (36.8 cm) H .
- Weight: 35 lb (15.8 kg).

Filter Regulator Lubricator (FRL) – 70 cfm

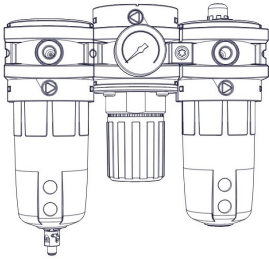

Part number: A700151

Extends the life of air tools; filter removes contaminants from the compressed air, adjustable regulator can reduce air pressure going to tools, lubricator adds atomized tool oil to the air stream to lubricate air tools (Tool oil not included).

- Max air flow: up to 70 cfm / 150 psi.
- Port size: 3/4 in NPT inlet and outlet.

Remote Muffler

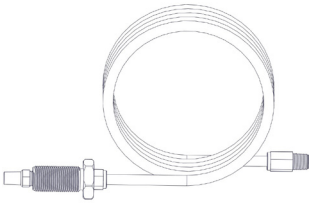

Part number: A700224

The A700224 WHASP remote mount muffler kit is designed to relocate the blowdown muffler to an external location. This is recommended for applications where the WHASP Tank will be located inside of a van or service body, the remote mounted muffler will reduce cabin noise when the compressor blowdown operates, and will ensure any oil vapor will be safely discharged outside of the vehicle.

Interface Harness Extension

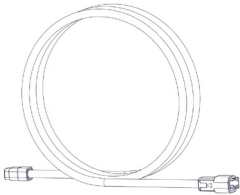

Part number: A700265

This interface harness extension provides an additional 10 ft of cable which allows for greater flexibility in locating the Interface Panel.

Warranty Registration

This form must be fully completed and returned to VMAC at the time the vehicle is put into service. Warranty may be void if this form is not received by VMAC within 3 months of receiving the vehicle, or 200 hours of operation, whichever occurs first.



VMAC's Warranty policy and registration can be viewed online at:

www.vmacair.com/warranty

Product Information

System Identification Number: **V** _____

Compressor Serial Number: **P** _____

Owner / End User Information

Company Name: _____

City: _____ State / Province: _____

Phone: (____) ____-_____

Email Address: _____

Date vehicle was put into service: ____/____/____
Day Month Year

Installer Information

Installer Company Name: _____

City: _____ State / Province: _____

Submitted by

Name: _____ Phone: (____) ____-_____

Email: _____

Vehicle Information (Optional)

Unit: _____ Year: _____

Make: _____ Model: _____

Vehicle Identification Number: _____

Manufactured by



888-241-2289



tech@vmacair.com



877-740-3202



warranty@vmacair.com



www.vmacair.com



kb.vmacair.com



1333 Kipp Road, Nanaimo, B.C., V9X 1R3 Canada