

**A700309 - Remote Oil Filter  
Manifold Installation**

**[www.vmacair.com](http://www.vmacair.com)**



# Table of Contents

Table of Contents .....	1
General Information .....	3
Safety .....	4
Safety Precautions.....	5
Remote Oil Filter Manifold Installation .....	7
Illustrated Parts List.....	9

Document #: 1901163  
 Changes and Revisions

Revision	Revision Details	Revised by	Checked by				Implemented
			Eng.		Tech.	Qual.	
			Mech.	Elec.			
A	ECN-20-187: Development Release	NDB	PID	N/A	DSB	LPH	12FEB2021
B	ECN-21-167: Changed to ORB Fittings	RRP	SIH	N/A	DSB	LPH	18OCT2021

## Important Information

The information in this manual is intended for approved VMAC installers who have been trained in installation and service procedures and/or for anyone with mechanical trade certification who have the tools and equipment to properly and safely perform the service. Do not attempt this service without the appropriate mechanical training, knowledge, and experience.

Follow all safety precautions for mechanical work. Any fabrication for correct fit in equipment must follow industry standard “best practices”.

## Notice

Copyright © 2021 VMAC Global Technology Inc. All Rights Reserved. These materials are provided by VMAC for informational purposes only, without representation or warranty of any kind, and VMAC shall not be liable for errors or omissions with respect to the materials. The only warranties for VMAC products and services are those set forth in the express warranty statements accompanying such products and services, if any, and nothing herein shall be construed as constituting an additional warranty. Printing or copying of any page in this document in whole or in part is only permitted for personal use. All other use, copying or reproduction in both print and electronic form of any part of this document without the written consent of VMAC is prohibited. The information contained herein may be changed without prior notice.

**Printed in Canada**

# General Information

## Introduction

This manual provides installation instructions for the remote oil filter manifold. Read this manual prior to servicing or operating the compressor system.

Follow all safety precautions when servicing or operating the VMAC system.

Proper service and repair are important to the safety of the operator and the safe, reliable operation of the equipment. Always use genuine VMAC replacement parts.

The procedures described in this manual are the only approved methods of service and operation.

## Ordering Parts

To order parts, contact the VMAC Inside Sales department. To assist in selecting the appropriate parts, please provide the VMAC compressor serial number, part number, description, and quantity. Contact VMAC Inside Sales by calling 1 (887) 912-6605 or by email to [sales@vmacair.com](mailto:sales@vmacair.com).

# Safety

## Important Safety Notice



The information contained in this manual is based on sound engineering principles, research, extensive field experience and technical information. Information is constantly changing with the addition of new models, assemblies, service techniques and running OEM changes. If a discrepancy is found in this manual, contact the VMAC OEM department prior to initiating or proceeding with installation, service or repair. Current information may clarify the issue. Anyone with knowledge of such discrepancies, who proceeds to perform service and repair, assumes all risks.

Only proven service procedures are recommended. Anyone who departs from the specific instructions provided in this manual must first assure that their safety and that of others is not being compromised, and that there will be no adverse effects on the operational safety or performance of the equipment.

VMAC will not be held responsible for any liability, consequential damages, injuries, loss or damage to individuals or to equipment as a result of the failure of anyone to properly adhere to the procedures set out in this manual or standard safety practices. Safety should be the first consideration when performing any service operations. If there are any questions concerning the procedures in this manual, or more information is required, please contact VMAC OEM department prior to beginning repairs.

## Safety Messages

This manual contains various warnings, cautions and notices that must be observed to reduce the risk of personal injury during installation, service or repair and the possibility that improper installation, service or repair may damage the equipment or render it unsafe.

	<p><i>This symbol is used to call attention to instructions concerning personal safety. Watch for this symbol; it points out important safety precautions, it means, "Attention, become alert! Your personal safety is involved". Read the message that follows and be aware of the possibility of personal injury or death. As it is impossible to warn of every conceivable hazard, common sense and industry standard safety practices must be observed.</i></p>
	<p><i>This symbol is used to call attention to instructions on a specific procedure that if not followed may damage or reduce the useful life of the compressor or other equipment.</i></p>
	<p><i>This symbol is used to call attention to additional instructions or special emphasis on a specific procedure.</i></p>

# Safety Precautions



*As it is impossible to warn of every possible hazard that may result from operating this system, common sense and industry standard safety practices must be observed.*

Read this information before operating the compressor for the first time. Follow the information and procedures in this manual for operation, maintenance and repair. Observe the following items to reduce the chance of personal injury or equipment damage.

Proper service and repair are important to the safety of the service technician and the safe, reliable operation of the equipment. Always use genuine VMAC replacement parts.

The procedures described in this service manual are effective methods of service and repair. Some procedures may require the use of tools specially designed for a specific purpose. Anyone using a replacement part, service procedure or tool must first determine that neither their safety nor the safe operation of the equipment will be compromised by the replacement part, service procedure or tool selected.



## Moving Parts Hazard

- Before performing service, disconnect the power source to prevent unexpected equipment start.
- Do not operate the system without guards in place. If the guards are damaged or missing, replace them before operating the equipment.



## Electrical Hazard

- Ensure the ground point connection is connected to the equipment body/chassis to prevent the chance of injury.
- Ensure the equipment is grounded appropriately.





## Burn Hazard

- The compressor system gets very hot during operation, contact with the components or the oil can cause serious injury. Allow sufficient time for the system to cool prior to performing service.
- Never allow any part of your body to contact the compressor components until the system has cooled sufficiently.

	<p><b>Compressor Air and Oil Hazard</b></p> <ul style="list-style-type: none"> <li>• The compressor system is under sufficient pressure that a leak could force the air/oil mixture through the skin directly into your bloodstream. This could cause serious injury or death.</li> <li>• Ensure the system is completely depressurized before attempting maintenance or repair.</li> <li>• Do not use compressed air to clean off clothing or skin, compressed air can penetrate the skin causing serious injury or death.</li> <li>• Do not move or service the system while it is pressurized or operating.</li> <li>• Components and hoses under pressure could separate suddenly and cause serious injury or death. If equipped, the air receiver tank must be drained prior to servicing the system.</li> <li>• Never adjust or attempt to make any repairs to the system while the engine is running. Components and hoses under pressure could fail and cause serious injury or death.</li> </ul>
---	---

	<p><b>Burst Hazard</b></p> <ul style="list-style-type: none"> <li>• Serious injury or death may result from an air tank explosion.</li> <li>• Never exceed manufacturer's maximum air pressure rating.</li> <li>• Do not repair components, only replace with approved parts.</li> <li>• Do not tamper with or disable factory safety equipment.</li> </ul>
---	---

  	<p><b>Personal Safety</b></p> <ul style="list-style-type: none"> <li>• Vaporized oil is a respiratory hazard, do not breathe the compressor air.</li> <li>• Always use the appropriate personal protective equipment, particularly eye and hearing protection when operating air powered equipment.</li> </ul>
---	--



# Remote Oil Filter Manifold Installation



*This filter manifold should be installed after the oil cooler and as close to the compressor as is reasonable. This ensures any debris in the cooler is caught by the filter and also minimizes the volume of oil that will end up in the compressor after system shutdown.*

## Installation Instructions

- Install the supplied ORB to JIC fittings onto either side of the manifold. These fittings may also be swapped out if a different size or fitting type is preferred. The ports on the manifold are #8 ORB.
- Apply Loctite 242 (blue Loctite) to the short end of the threaded filter nipple port and install short end of the filter nipple into port, see Figure 1. Tighten hand tight.

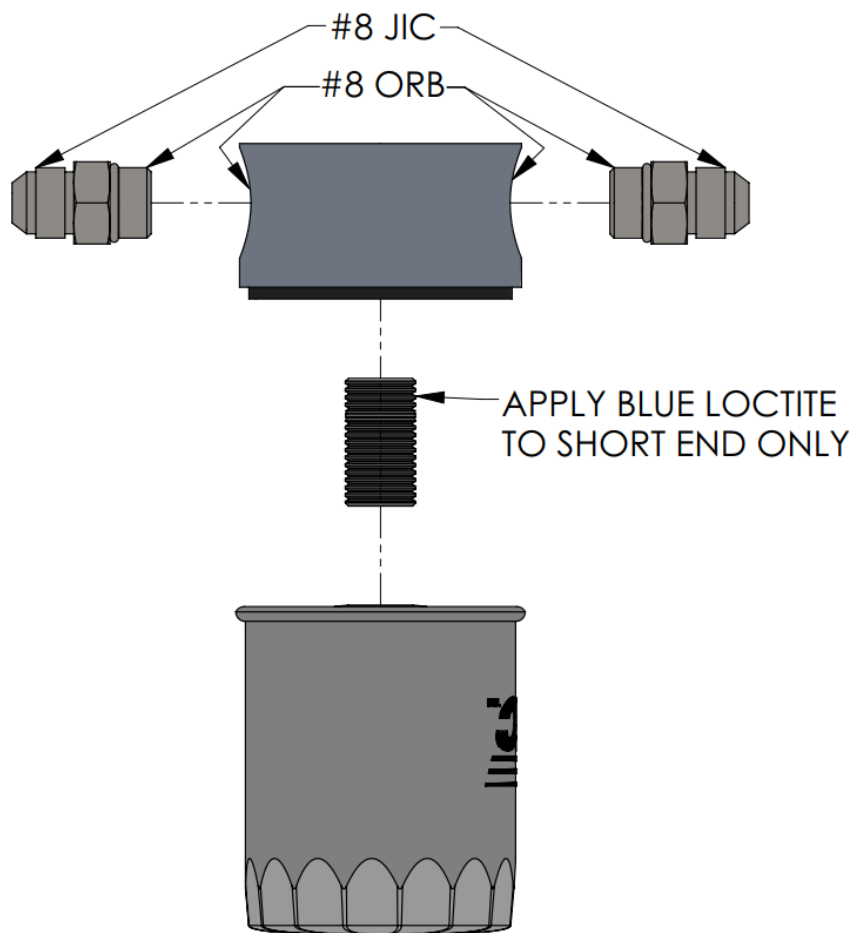

**Figure 1 – Remote Oil Filter Assembly Instructions**

- Install the manifold by mounting it using the two M8x1.25 threaded holes on the opposite side of the filter as shown in Figure 2. Alternatively, the manifold may be hard mounted via either pipe connection (i.e., to the outlet of the cooler) if desired. The manifold may be mounted in any orientation but keep in mind ease of access to remove filter and collect the oil that is released.

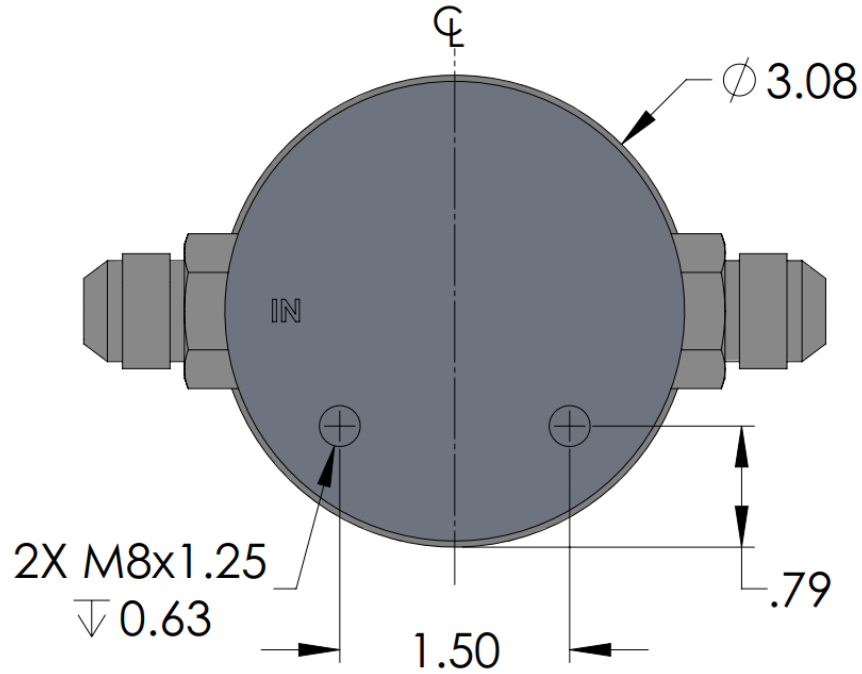

Dimensions shown are in inches

**Figure 2 – Mounting Dimensions for Remote Oil Filter Manifold**

	<p><i>There is an engraved "IN" on the manifold which must connect to the oil line coming from the air-oil separation tank and cooler. If the connections are reversed oil flow will be blocked by the filter's anti-drainback check valve and compressor damage may result.</i></p>
--	--

- Apply a light film of clean oil to the filter gasket and spin the filter onto the threaded nipple until the gasket contacts the sealing surface on the tank then tighten the filter an additional 3/4 to 1 turn.

# Illustrated Parts List

## Remote Oil Filter Manifold – A700309

Item #	Part #	Qty	Description
1	3200510	1	MANIFOLD, OIL FILTER
2	4900035	1	NIPPLE, 3/4 - 16
3	9200039	1	OIL FILTER, VR 3.250 SHORT
4	4900200	2	FTG, STR, #8MORB-#8MJIC, VITON

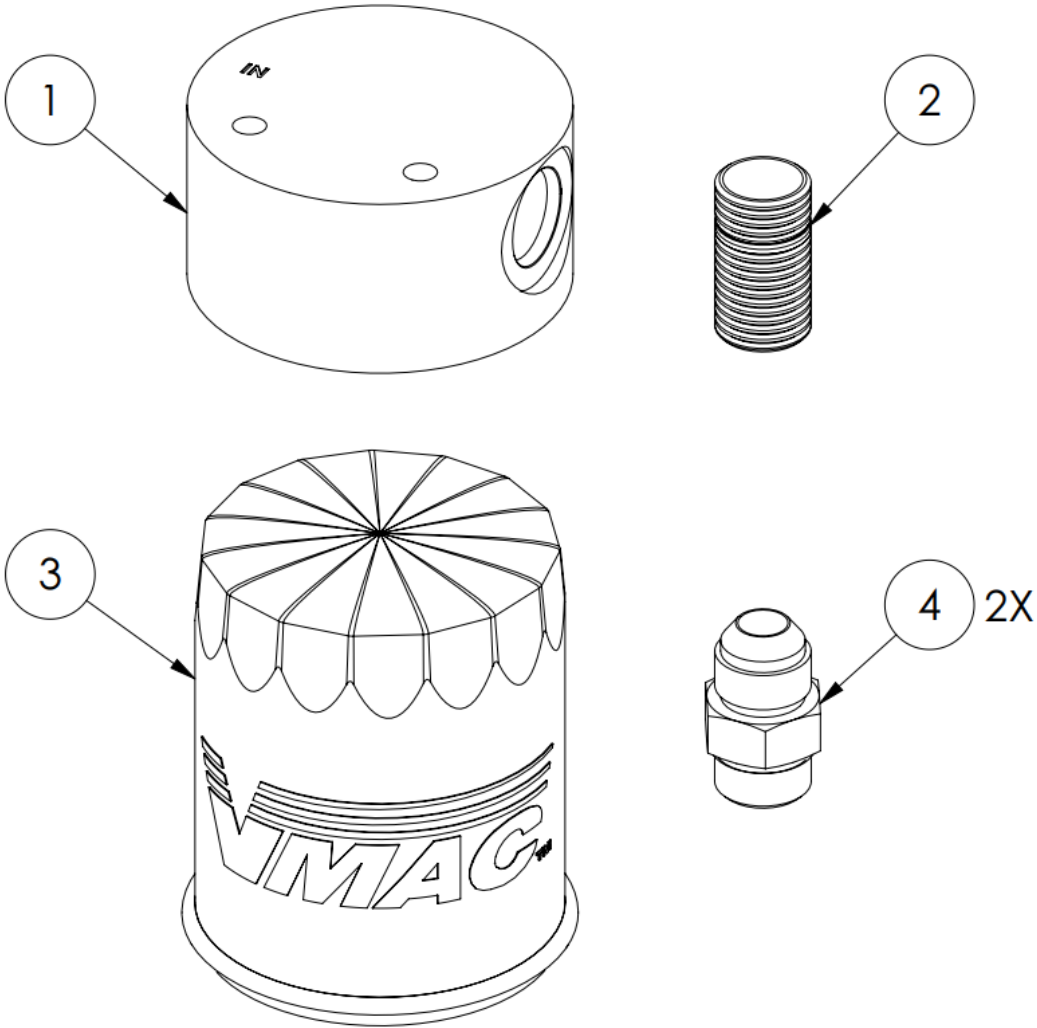

**Figure 3 - A700309**

Manufactured by



888-241-2289



tech@vmacair.com



877-740-3202



warranty@vmacair.com



www.vmacair.com



www.kb.vmacair.com



1333 Kipp Road, Nanaimo, B.C., V9X 1R3 Canada